

PRODUCT GUIDE



1

**ELECTRONICS IN THE
CONTROL CABINET**



2

INTERFACES



3

**CONNECTION
TECHNOLOGY**



4

I/O SYSTEMS

PRODUCT GUIDE

Note:

With this catalog, all information contained in previous brochures/catalogs expires. All drawings, diagrams, indications of weight, dimensions, ratings or other details printed in this catalog are only binding when specifically agreed upon.

Murrelektronik reserves the right to changes and modifications. The customer is responsible for using the components and units that they ordered in the way they are designed.

The information in this brochure has been compiled with the utmost care. Liability for the correctness, completeness and topicality of the information is restricted to gross negligence.

1st edition: June 2015

Part No. 9800502

Murrelektronik GmbH,
Falkenstr. 3, D-71570 Oppenweiler

www.murrelektronik.com

With compliments:

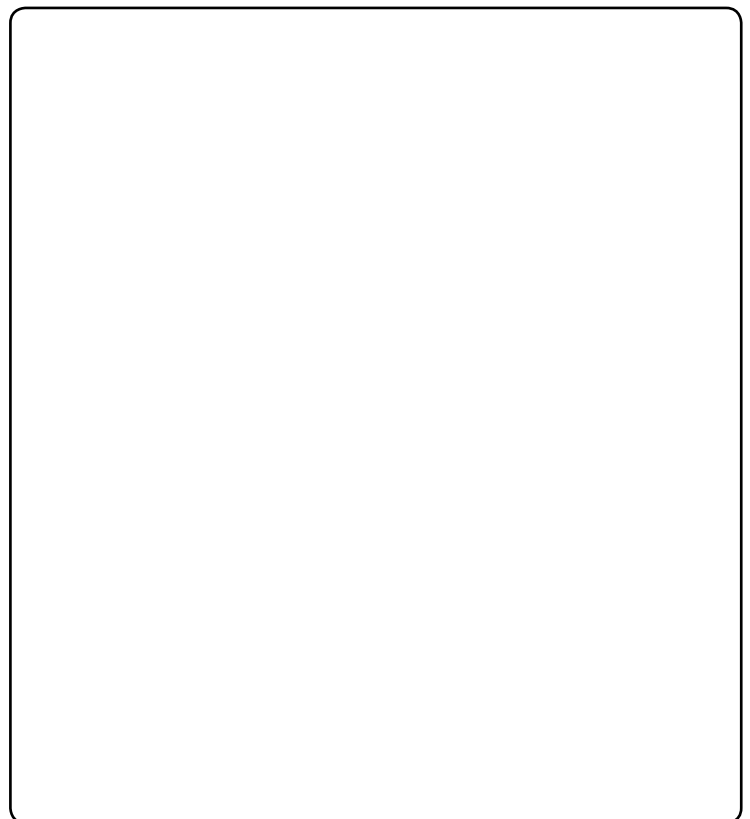



**24 BRANCH OFFICES
AND 4 PRODUCTION PLANTS**

Oppenweiler
Production Fieldbus Systems,
Interface modules

Stollberg, Germany
Production of Connectors

Stod, Czech Republic
Production of Interface, Switch Mode
Power Supplies, Transformers



**STAY CONNECTED – REPRESENTED
ON ALL CONTINENTS WORLDWIDE**

The company was founded in
1975 by Franz Hafner

Over 1,900 employees, including
200 sales reps and customer
service center technicians

Top student training is very important
for Murrelektronik. Each year we offer
apprenticeships in technical and
commercial areas, as well as in logistics.





MURRELEKTRONIK FIGURES & FACTS

Shanghai, China
Production for the
Asian markets



MURRELEKTRONIK IS YOUR PARTNER...

- Over 42,000 products available to order conveniently in our online shop
- Subdivided into four product fields:
 - **Electronics in the Control Cabinet**
 - **Interfaces**
 - **Connection Technology**
 - **I/O Systems**
- For industries and market segments as for example:
 - **Machine Tools**
 - **Machine Building and Plant Engineering**
 - **Assembly and Handling Technology**
 - **Food and Beverage**
 - **Automotive Industry**
 - **Warehousing and Logistics**
- Founded in Oppenweiler, Germany, in 1975
- Family-owned company
- Over €220 million turnover in the year 2014



TRANSFORMERS SAFE AND RELIABLE

- Approvals for the global market
- Flexible and versatile
- Customized solutions

MTS, MST, MET OR MTL – THE RIGHT TRANSFORMER FOR EVERY APPLICATION

Different situations require different voltages. Transformers have to be just as flexible as the application. Murrelektronik's range provides you with the flexibility you need! No matter if it's an isolation transformer, control transformer, or safety transformer – we have the right solution for any application. Murrelektronik's transformers are reliable, safe and their approvals and voltage ranges make them ideal for worldwide use.

Transformers



MTS – Isolation class T 40/B

- Nominal power rating: 40...250 VA
- Input voltage: 230, 400 V AC or multi voltage (± 15 V AC)
- Output voltage: 24 V AC or 230 V AC
- Ambient temperature: 40 °C

Page 1.1.1



MST – Isolation class T 40/B

- Nominal power rating: 320...1000 VA
- Input voltage: 230, 400 V AC or multi voltage
- Output voltage: 24 V AC or 230 V AC
- Ambient temperature: 40 °C

Page 1.1.2



MET – Isolation class T 60/B

- Nominal power rating: 500...5000 VA
- Input voltage: 230 V AC $\pm 5\%$, 400 V AC $\pm 5\%$, 240/415 V AC $\pm 5\%$
- Output voltage: 24, 230, 110/240 V AC
- Ambient temperature: 60 °C

Page 1.1.3



MTL – Isolation class T 60/B

- Nominal power rating: 25...2500 VA
- Input voltage: 230/400 V AC ± 15 V AC
- Output voltage: 2 x 24 V AC or 2 x 115 V AC
- Ambient temperature: 60 °C

see onlineshop.murrelektronik.com/en

TRANSFORMERS

1-/2-phase

– INPUT: 230/400 V AC

– Isolation class T 40/B

Approvals:

MTS

OUTPUT: 230 V AC
Screw terminals



MTS

OUTPUT: 230 V AC
Spring clamp terminals

MTS

OUTPUT: 24 V AC
Screw terminals

MTS

OUTPUT: 24 V AC
Spring clamp terminals

Circuit diagram

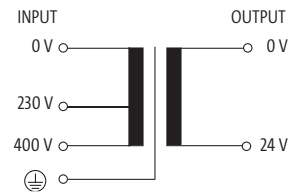
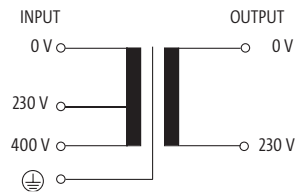

Order Data	HxWxD/kg	Art-No.	HxWxD/kg	Art-No.	HxWxD/kg	Art-No.	HxWxD/kg	Art-No.
40 VA	79x78x93/0.8	86346	79x78x93/0.8	6686346	79x78x93/0.8	86340	79x78x93/0.8	6686340
63 VA	79x78x93/1.2	86347	79x78x93/1.2	6686347	79x78x93/1.2	86341	79x78x93/1.2	6686341
100 VA	86x84x98/2.0 – GL	86348	86x84x98/2.0	6686348	86x84x98/2.0 – GL	86342	86x84x98/2.0	6686342
160 VA	101x96x106/2.7 – GL	86349	101x96x106/2.7	6686349	101x96x106/2.7 – GL	86343	101x96x106/2.7	6686343
250 VA	102x96x108/3.5 – GL	86351	102x96x108/3.5	6686351	102x96x108/3.5 – GL	86345	102x96x108/3.5	6686345

Input		
Frequency	50...60 Hz	
Input voltage	230/400 V AC	
Output		
Output voltage	230 V AC	24 V AC (SELV)
General data		
Standards	(EN 61558-1), (EN 61558-2-4), (EN 62041 category 0)	
Test isolation voltage	4 kV (prim./sec.)	
Mounting method	Long-hole mounting or DIN-rail mountable TH35 (EN 60715)	
Temperature range	-20...+40 °C, no condensation	

Dimension drawing

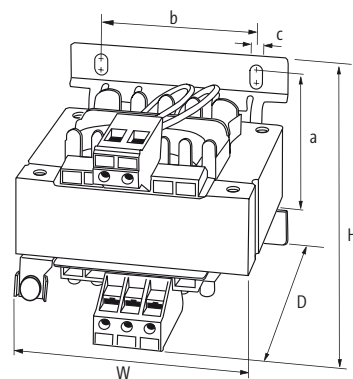

Notes
GL-Approval from 100 VA and with screw terminals

TRANSFORMERS

1-/2-phase

– INPUT: 208...520 V AC

– Isolation class T 40/B

Approvals:  

MST Multi

OUTPUT: 2 × 115 V AC/230 V AC

Screw terminals



Circuit diagram

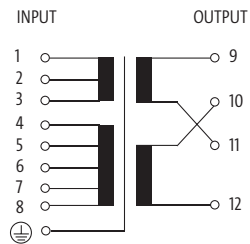

Order Data	H×W×D/kg	Art-No.
250 VA	104×120×122/4.0 – GOST	86145
320 VA	115×135×132/5.8 – GOST	86146
400 VA	115×135×132/6.2 – GOST	86147
500 VA	138×135×135/5.8	86148
800 VA	156×150×150/7	86150
1000 VA	128×174×160/12.3 – GOST	86151
1600 VA	168×174×163/7	86152
2000 VA	185×192×185/10	86153
2500 VA	200×195×217/10	86154
3000 VA	250×197×193/29.5 – GOST	86155
5000 VA	248×197×250/9	86157

Input	
Input voltage	208, 230, 380, 400, 420, 440, 460, 480, 500, 525, 550 V AC
Frequency	50...60 Hz

Output	
Output voltage	2 × 115 V AC/230 V AC

General data	
Standards	(EN 61558-1), (EN 61558-2-4), (EN 62041 category 0)
Test isolation voltage	4 kV (prim./sec.)
Mounting method	Key-hole mounting
Temperature range	-20...+40 °C, no condensation

Dimension drawing

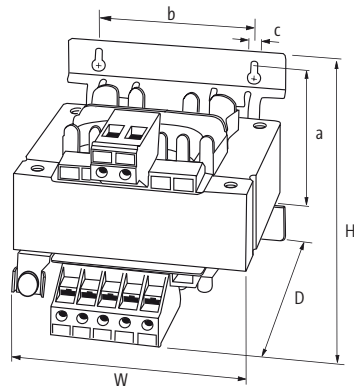

Notes

TRANSFORMERS

1-/2-phase

– OUTPUT: 230 V AC

– Isolation class T 40/B

Approvals: 

MET

INPUT: 230 V AC
Screw terminals



MET

INPUT: 230 V AC
Spring clamp terminals

MET

INPUT: 400 V AC
Screw terminals

MET

INPUT: 400 V AC
Spring clamp terminals

Circuit diagram

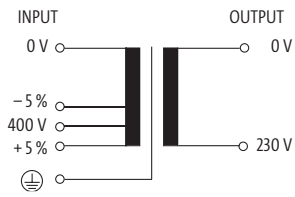
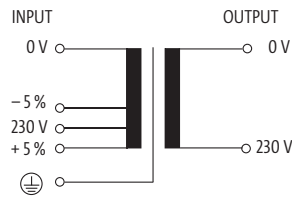

Order Data	HxWxD/kg	Art-No.	HxWxD/kg	Art-No.	HxWxD/kg	Art-No.	HxWxD/kg	Art-No.
2000 VA	170x195x250/24.0 – GL	86070	170x195x250/24.0	6686070	170x195x250/24.0 – GL	86071	170x195x250/24.0	6686071
3000 VA	195x198x250/30.0 – GL	86090	195x198x250/30.0	6686090	195x198x250/30.0 – GL	86091	195x198x250/30.0	6686091
4000 VA	206x198x250/32.0 – GL	86110	206x198x250/32.0	6686110	206x198x250/32.0 – GL	86111	206x198x250/32.0	6686111
5000 VA	225x198x250/40.0 – GL	86130	225x198x250/40.0	6686130	225x198x250/40.0 – GL	86131	225x198x250/40.0	6686131

Input	230 V AC ± 5 %	400 V AC ± 5 %
Input voltage	230 V AC ± 5 %	400 V AC ± 5 %
Frequency	50...60 Hz	

Output	230 V AC
Output voltage	230 V AC

General data	(EN 61558-1), (EN 61558-2-4), (EN 62041 category 0)
Standards	(EN 61558-1), (EN 61558-2-4), (EN 62041 category 0)
Test isolation voltage	4 kV (prim./sec.)
Mounting method	Long-hole mounting
Temperature range	-20...+40 °C, no condensation

Dimension drawing

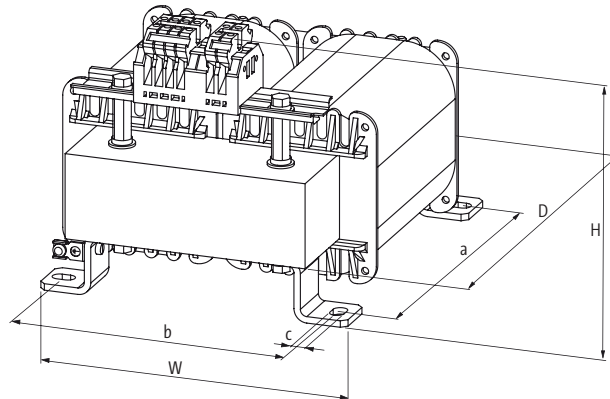

Notes



POWER SUPPLY UNITS

EMPARRO – SIMPLY THE BEST

- Up to 95 % efficiency
- 150 % power boost for 4 seconds
- Cutting edge technology

EMPARRO – THE POWER SUPPLY WITH MAXIMUM EFFICIENCY

- Efficiency up to 95 %
- 150 % power boost for 4 seconds
- Metal housing with optimum EMC characteristics
- No derating between -25°C to +60°C
- Very small width
- High mains failure bridging time
- Seven models, the solution for many applications

Emparro Compared to the Competitors

The comparison is based on the same input current: Emparro (left) emits significantly less heat energy than conventional power supply units. The device itself remains cooler which protects the components installed near the unit. This increases their lifetime.



Power Supply Units



Emparro

- Single-phase
- 150 % power boost
- Spring clamp terminals

Page 1.2.1



ECO Rail/ECO Power

- Single-phase
- Full power up to 40 °C ambient temperature
- Screw terminal connection

Page 1.2.3



Emparro

- Three-phase
- 150 % power boost
- Spring clamp terminals

Page 1.2.5



PICCO

- 16 models
- 12 V or 24 V outputs
- 10 W, 30 W, 60 W oder 100 W

see onlineshop.murrelektronik.com/en



MCS-B

- Single-phase
- Wide voltage input
- Parallel and series operation possible

see onlineshop.murrelektronik.com/en



Evolution67/Emparro67

- Single-phase
- IP67

see onlineshop.murrelektronik.com/en



Evolution/Evolution+

- Two-/three-phase
- Extended temperature range of -25 °C ... +70 °C
- Approvals for applications worldwide

Page 1.2.8

POWER SUPPLY UNITS

Single-phase, primary switched

– short-circuit and overload protected

Approvals:

Emparro

OUTPUT: 12 V DC



Emparro

OUTPUT: 48 V DC

Emparro

OUTPUT: 48 V DC



Emparro

OUTPUT: 48 V DC



Order Data	Art-No.	Art-No.	Art-No.	Art-No.
12 V DC/10 A	85434			
48 V DC/2.5 A		85437		
48 V DC/5 A			85438	
48 V DC/10 A				85439

Input				
Input voltage	85...265 V AC/90...250 V DC			
Input current	1.2 A (100 V AC); 0.6 A (230 V AC)	1.2 A (100 V AC); 0.6 A (240 V AC)	2.6 A (100 V AC); 1.1 A (240 V AC)	5.1 A (100 V AC); 2.4 A (240 V AC)
Inrush current after 1 ms	max. 10 A (230 V AC)	max. 3.5 A (230 V AC)	max. 5.5 A (230 V AC)	max. 11 A (230 V AC)
Power factor	0.88 (230 V AC)	0.87 (230 V AC)	0.95 (230 V AC)	0.94 (230 V AC)
Primary fusing external	max. 20 A (T), cable protection			
Frequency	50...60 Hz			
Output				
Output voltage	12 V DC (SELV), ±1%; 12...15 V adjustable	48 V DC (SELV), ±1%; 48...56 V adjustable		
Power Boost	I _{out} × 150 % (min. 4 s)			
Output current	10 A	2.5 A	5 A	10 A
Mains failure bridging time	min. 30 ms (100 V AC); 10 A (12 V DC)	min. 30 ms (100 V AC); 2.5 A (48 V DC)	min. 30 ms (100 V AC); 5 A (48 V DC)	min. 30 ms (100 V AC); 10 A (48 V DC)
Ripple	max. 50 mVrms			
Spikes	max. 200 mV p-p			
Unit protection	short-circuit and overload protected			
LED display	LED (green): OK; LED (red): overload, overheating or short-circuit			
Parallel usage/serial usage	max. 5 units/max. 2 units			
General data				
Standards	(EN 60950-1), (EN 61204-3), (EN 55011 B), (EN 61000-3-2)			
Relative humidity	5...95 %, no condensation			
Efficiency	92.7 % (12 V DC/7.5 A)	93.7 % (48 V DC/1.88 A)	94.5 %	95 %
Mounting method	DIN-rail mountable TH35 (EN 60715)			
Temperature range	-25...+60 °C, ...+70 °C derating (storage temperature -40...+80 °C)			

Dimension drawing				

Notes				

POWER SUPPLY UNITS

Single-phase, primary switched

– short-circuit and overload protected

Approvals: 

Emparro

OUTPUT: 24 V DC



Emparro

OUTPUT: 24 V DC



Emparro

OUTPUT: 24 V DC

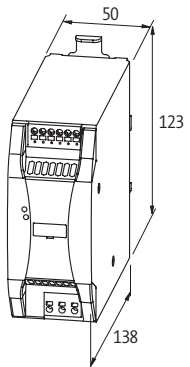
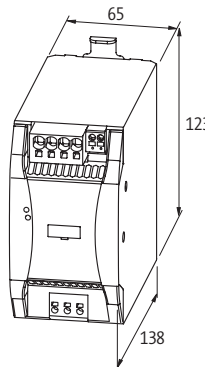
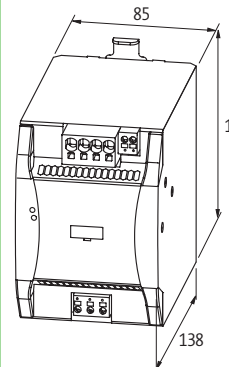

Order Data	Art-No.	Art-No.	Art-No.
24 V DC/5 A	85440		
24 V DC/10 A		85441	
24 V DC/20 A			85442
Input			
Input voltage	85...265 V AC/90...250 V DC		90...265 V AC/90...250 V DC
Input current	1.3 A (100 V AC); 0.61 A (240 V AC)	2.6 A (100 V AC); 1.1 A (240 V AC)	5.2 A (100 V AC); 2.2 A (240 V AC)
Inrush current after 1 ms	max. 5.5 A (230 V AC)	max. 13 A	max. 23 A (230 V AC)
Power factor	0.87 (230 V AC)	0.95 (230 V AC)	0.96 (230 V AC)
Primary fusing external	20 A (T)		
Frequency	50...60 Hz		
Output			
Output voltage	24 V DC (SELV), ±1 %; 24...28 V adjustable		
Power Boost	I _{out} N × 150 % (min. 4 s)		
Output current	5 A	11.8 A	20 A
Mains failure bridging time	min. 30 ms (230 V AC); 5 A (24 V DC)	min. 30 ms (110 V AC; 25 °C; U _{out} N × I _{out} N)	min. 30 ms (230 V AC); 20 A (24 V DC)
Ripple	max. 50 mVrms		
Spikes	max. 200 mV p-p		
Unit protection	short-circuit and overload protected		
LED display	LED (green): OK; LED (red): overload, overheating or short-circuit		
Parallel usage/serial usage	max. 5 units/max. 2 units		
General data			
Standards	(EN 60950-1), (EN 61204-3), (EN 55011 B), (EN 61000-3-2)		
Relative humidity	5...95 %, no condensation		
Efficiency	92.7 % (110 V AC); 93.4 % (230 V AC)	94.3 % (230 V AC)	93.8 % (230 V AC)
Mounting method	DIN-rail mountable TH35 (EN 60715)		
Temperature range	-25...+60 °C, ...+70 °C derating (storage temperature -40...+80 °C)		
Dimension drawing			
			
Notes			

POWER SUPPLY UNITS

Single-phase

– short-circuit and overload protected

Approvals:  

Eco Rail

OUTPUT: 24 V DC
Current: 1.3 A



Eco Rail

OUTPUT: 24 V DC
Current: 2.5 A

Eco Rail

OUTPUT: 24 V DC
Current: 5 A

Circuit diagram

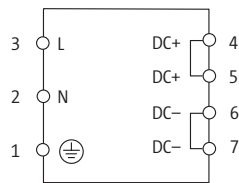

Order Data	H×W×D	Art-No.	H×W×D	Art-No.	H×W×D	Art-No.
24 V DC/1.3 A	125×50×70 mm	85301				
24 V DC/2.5 A			125×50×80 mm	85302		
24 V DC/5 A					125×50×125 mm	85303

Input						
Input voltage	100...240 V AC				90...132 V AC/173...264 V AC	
Input current	0.7 A (115 V AC); 0.4 A (230 V AC)		1.1 A (115 V AC); 0.6 A (230 V AC)		2.3 A (115 V AC); 1.2 A (230 V AC)	
Inrush current after 1 ms	max. 20 A					
Primary fusing external	max. 20 A					
Frequency	50...60 Hz					
Output						
Output voltage	24 V DC ±1%					
Output current	1.3 A (+40 °C); 1.0 A (+55 °C)		2.5 A (+40 °C); 2.0 A (+55 °C)		5 A (+40 °C); 4 A (+55 °C)	
Mains failure bridging time	min. 25 ms (115 V AC); min. 130 ms (230 V AC)		min. 20 ms (115 V AC); min. 100 ms (230 V AC)		min. 40 ms (115 V AC); min. 40 ms (230 V AC)	
Ripple	max. 20 mVrms					
Unit protection	short-circuit and overload protected					
Spikes	max. 100 mV p-p				max. 60 mV p-p	
LED display	LED (green) for output voltage					
Parallel usage/serial usage	no/yes (max. 2 units)					
General data						
Standards	(EN 60950-1), (EN 61204-3), (EN 55022 B), (EN 61000-3-2)					
Mounting method	DIN-rail mountable TH35 (EN 60715)					
Efficiency	84 % (115 V AC); 84 % (230 V AC)		85 % (115 V AC); 87 % (230 V AC)		84 % (115 V AC); 86 % (230 V AC)	
Relative humidity	20...90 %, no condensation					
Temperature range	0...+40 °C, ...+50 °C derating (storage temperature -20...+85 °C)					

Dimension drawing

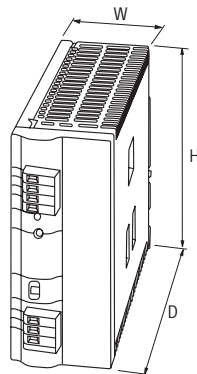

Notes

POWER SUPPLY UNITS

Single-phase

– short-circuit and overload protected

Approvals:  

Eco Rail

OUTPUT: 24 V DC
Current: 10 A



Eco Rail

OUTPUT: 24 V DC
Current: 20 A



Circuit diagram

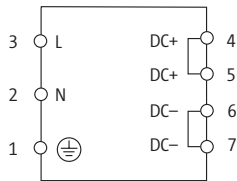

Order Data	HxWxD	Art-No.	HxWxD	Art-No.
24 V DC/10 A	125x72x125 mm	85305		
24 V DC/20 A			125x105x127 mm	85307
Input				
Input voltage	90...132 V AC/173...264 V AC			
Input current	4 A (115 V AC); 2.4 A (230 V AC)		9 A (100 V AC); 4.5 A (200 V AC)	
Inrush current after 1 ms	max. 20 A		max. 30 A	
Primary fusing external	max. 20 A			
Frequency	50...60 Hz			
Output				
Output voltage	24 V DC ±1 %			
Output current	10 A (+40 °C); 7.5 A (+55 °C)		20 A (+40 °C); 16 A (+55 °C)	
Mains failure bridging time	min. 20 ms (115 V AC); min. 20 ms (230 V AC)		min. 15 ms (115 V AC); min. 30 ms (230 V AC)	
Ripple	max. 20 mVrms		max. 50 mVrms	
Unit protection	short-circuit and overload protected			
Spikes	max. 150 mV p-p		max. 100 mV p-p	
LED display	LED (green) for output voltage			
Parallel usage/serial usage	no/yes (max. 2 units)			
General data				
Standards	(EN 60950-1), (EN 61204-3), (EN 55022 B)			
Mounting method	DIN-rail mountable TH35 (EN 60715)			
Efficiency	87 % (115 V AC); 88 % (230 V AC)		87 % (115 V AC); 89 % (230 V AC)	
Relative humidity	20...90 %, no condensation			
Temperature range	0...+40 °C, ...+50 °C derating (storage temperature -20...+85 °C)			
Dimension drawing				

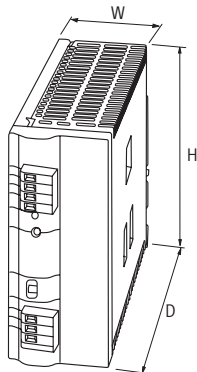

Notes

POWER SUPPLY UNITS

3-phase

– short-circuit and overload protected

Emparro

OUTPUT: 24 V DC



Emparro

OUTPUT: 24 V DC



Emparro

OUTPUT: 24 V DC



Order Data	Art-No.	Art-No.	Art-No.
24 V DC/5 A	85690		
24 V DC/10 A		85691	
24 V DC/20 A			85692
Input			
Input voltage	3 × 324...572 V AC/450...745 V DC		
Input current	0.45 A (3 × 360 V AC)	0.75 A (3 × 360 V AC); 0.45 A (3 × 500 V AC)	1.3 A (3 × 360 V AC); 1.0 A (3 × 500 V AC)
Inrush current after 1 ms	max. 9.5 A	max. 9 A	max. 13 A
Power factor	0.61 (3 × 400 V AC)	0.66 (3 × 500 V AC)	0.65
Primary fusing external	3 × 20 A (T)		
Frequency	50...60 Hz		
Output			
Output voltage	24 V DC (SELV), ±1 %; 24...28 V adjustable		
Power Boost	I _{out} N × 150 % (min. 5 s)		
Output current	3.7 A (70 °C); 5.0 A (60 °C); 6.0 A (45 °C)	12 A (45 °C); 10 A (60 °C); 7 A (70 °C)	15 A (70 °C); 20 A (60 °C); 24 A (45 °C)
Mains failure bridging time	min. 25 ms (3 × 360 V AC); 5 A (24 V DC)	min. 45 ms (3 × 500 V AC); 10 A (24 V DC)	min. 40 ms (3 × 500 V AC)
Ripple	max. 20 mVrms		
Spikes	max. 50 mV p-p		max. 90 mV p-p
Unit protection	short circuit and overload protected, permanently by 20 % (to 45 °C)		
LED display	LED (green): OK; LED (red): overload, overheating or short-circuit		
Parallel usage/serial usage	max. 3 units		
General data			
Standards	(EN 60950-1), (EN 61204-3), (EN 55011 B), (EN 61000-3-2)		
Relative humidity	5...95 %, no condensation		
Efficiency	92.5 % (3 × 400 V AC); 91.8 % (3 × 480 V AC)	93.7 % (3 × 400 V AC); 93.2 % (3 × 480 V AC)	94.8 % (3 × 400 V AC); 94.5 % (3 × 480 V AC)
Mounting method	DIN-rail mountable TH35 (EN 60715)		
Temperature range	-25...+60 °C, ...+70 °C derating (storage temperature -40...+80 °C)		
Dimension drawing			
Notes			

POWER SUPPLY UNITS

Single-phase

– short-circuit and overload protected

Eco Power

OUTPUT: 24 V DC
Current: 1.3 A



Eco Power

OUTPUT: 24 V DC
Current: 2.5 A

Circuit diagram

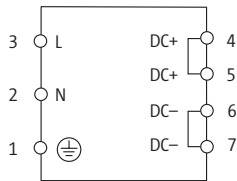

Order Data	HxWxD	Art-No.	HxWxD	Art-No.
24 V DC/1.3 A	36x77x105 mm	85151		
24 V DC/2.5 A			40x98x135 mm	85152

Input	
Input voltage	100...240 V AC
Input current	0.7 A (115 V AC); 0.4 A (230 V AC) 1.2 A (115 V AC); 0.5 A (230 V AC)
Inrush current after 1 ms	max. 20 A
Primary fusing external	max. 16 A
Frequency	50...60 Hz
Output	
Output voltage	24 V DC \pm 1 %
Output current	1.3 A (+40 °C); 1.04 A (+50 °C) 2.5 A (+40 °C); 2.0 A (+50 °C)
Mains failure bridging time	min. 10 ms (115 V AC); min. 90 ms (230 V AC)
Ripple	max. 20 mVrms
Unit protection	short-circuit and overload protected
Spikes	max. 100 mV p-p
LED display	LED (green) for output voltage
Parallel usage/serial usage	no/yes (max. 2 units)
General data	
Standards	(EN 60950-1), (EN 61204-3), (EN 55011 B)
Mounting method	screw fixing, M3
Efficiency	85 % (115 V AC); 85 % (230 V AC) 85 % (115 V AC); 87 % (230 V AC)
Relative humidity	20...90 %, no condensation
Temperature range	0...+40 °C, ...+50 °C derating (storage temperature -20...+85 °C)
Dimension drawing	

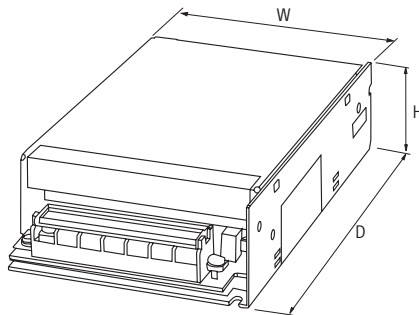

Notes

POWER SUPPLY UNITS

Single-phase

– short-circuit and overload protected

Eco Power

OUTPUT: 24 V DC
Current: 5 A



Eco Power

OUTPUT: 24 V DC
Current: 7.5 A

Eco Power

OUTPUT: 24 V DC
Current: 10 A

Circuit diagram

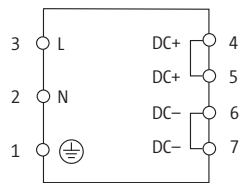

Order Data	H×W×D	Art-No.	H×W×D	Art-No.	H×W×D	Art-No.
24 V DC/5 A	41×98×164 mm	85153				
24 V DC/7.5 A			50×100×205 mm	85154		
24 V DC/10 A					50×115×230 mm	85155

Input						
Input voltage	100...240 V AC		100...120 V AC/200...240 V AC			
Input current	2.4 A (115 V AC); 1.0 A (230 V AC)		3.4 A (115 V AC); 1.9 A (230 V AC)		4.6 A (115 V AC); 2.8 A (230 V AC)	
Inrush current after 1 ms	max. 20 A					
Primary fusing external	max. 16 A					
Frequency	50...60 Hz					
Output						
Output voltage	24 V DC ±1%					
Output current	5 A (+40 °C); 4 A (+50 °C)		7.5 A (+40 °C); 6 A (+50 °C)		10 A (+40 °C); 8 A (+50 °C)	
Mains failure bridging time	min. 15 ms (115 V AC); min. 80 ms (230 V AC)		min. 20 ms (115 V AC); min. 20 ms (230 V AC)		min. 15 ms (115 V AC); min. 15 ms (230 V AC)	
Ripple	max. 30 mVrms		max. 50 mVrms		max. 30 mVrms	
Spikes	max. 100 mV p-p				max. 200 mV p-p	
Unit protection	short-circuit and overload protected					
LED display	LED (green) for output voltage					
Parallel usage/serial usage	no/yes (max. 2 units)					
General data						
Standards	(EN 60950-1), (EN 61204-3), (EN 55011 B)					
Mounting method	screw fixing, M3				screw fixing, M4	
Efficiency	86 % (115 V AC); 87 % (230 V AC)		85 % (115 V AC); 86 % (230 V AC)		84 % (115 V AC); 85 % (230 V AC)	
Relative humidity	20...90 %, no condensation					
Temperature range	0...+40 °C, ...+50 °C derating (storage temperature -20...+85 °C)					

Dimension drawing

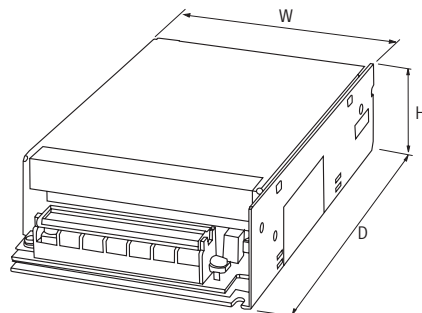

Notes

POWER SUPPLY UNITS

2-/3-phase

– stable output voltage,
short-circuit and
overload protected

Approvals:  

Evolution

OUTPUT: 24 V DC \pm 1%
Current: 5 A



Evolution

OUTPUT: 24 V DC \pm 1%
Current: 10 A



Evolution

OUTPUT: 24 V DC \pm 1%
Current: 20 A



Evolution

OUTPUT: 24 V DC \pm 1%
Current: 40 A



Circuit diagram

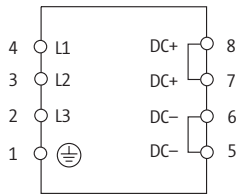

Order Data	HxWxD/kg	Art-No.	HxWxD/kg	Art-No.	HxWxD/kg	Art-No.	HxWxD/kg	Art-No.
24 V DC/5 A	132x83x98/1.0 – GOST	85000						
24 V DC/10 A			132x93x114/1.3	85001				
24 V DC/20 A					132x113x136/2.0	85002		
24 V DC/40 A							132x164x142/3.0	85004

Input

Input voltage	3 x 324...572 V AC/480...745 V DC			
Input current	3 x 0.3 A	3 x 0.8 A	3 x 1.3 A	3 x 2.4 A
Inrush current after 1 ms	max. 10 A	max. 15 A	max. 19 A	–
Primary fusing external	max. 3 x 10 A	3 x 10 A (T)	max. 3 x 20 A	
Frequency	50...60 Hz			

Output

Output voltage	24 V DC (SELV), \pm 1 %; 22...28 V adjustable			
Output current	5 A (+55 °C); 3 A (+70 °C)	10 A (+55 °C); 6.5 A (+70 °C)	20 A (+55 °C); 15.8 A (+70 °C)	40 A (+55 °C); 30 A (+70 °C)
Power Boost	I _{out} N x 150 % (min. 4 s)			
Mains failure bridging time	min. 30 ms (400 V AC)	min. 19 ms (400 V AC)		
Ripple	max. 50 mVrms			
Spikes	max. 100 mV p-p			
LED display	LED (green): OK; LED (red): overload			
Parallel usage/serial usage	max. 5 units/max. 2 units			

General data

Standards	(EN 60950-1), (EN 61204-3), (EN 55022 B), (EN 61000-3-2)	(EN 60950-1), (EN 61204-3), (EN 55011 A)
Relative humidity	5...95 %, no condensation	
Efficiency	86 %	90 %
Mounting method	DIN-rail mountable TH35 (EN 60715)	
Protection	IP20	
Temperature range	-25...+70 °C (storage temperature -40...+85 °C)	

Dimension drawing

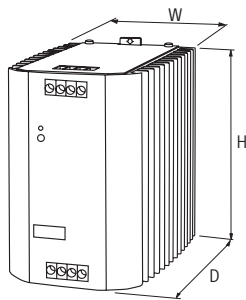

Notes

POWER SUPPLY UNITS

2-/3-phase

– stable output voltage,
short-circuit and
overload protected



Evolution+

OUTPUT: 24 V DC ± 1%
Current: 5 A



Evolution+

OUTPUT: 24 V DC ± 1%
Current: 10 A



Evolution+

OUTPUT: 24 V DC ± 1%
Current: 20 A



Evolution+

OUTPUT: 24 V DC ± 1%
Current: 40 A



Circuit diagram

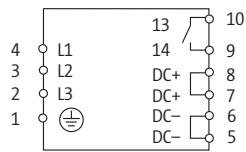

Order Data	H×W×D/kg	Art-No.	H×W×D/kg	Art-No.	H×W×D/kg	Art-No.	H×W×D/kg	Art-No.
24 V DC/5 A	132×83×98/1.0	85640						
24 V DC/10 A			132×93×114/1.2	85641				
24 V DC/20 A					132×113×136/2.0	85642		
24 V DC/40 A							132×164×142/3.0	85644

Input	
Input voltage	3 × 324...572 V AC/480...745 V DC
Input current	3 × 0.45 A 3 × 0.8 A 3 × 1.3 A 3 × 2.4 A
Inrush current after 1 ms	max. 10 A max. 15 A max. 19 A –
Primary fusing external	3 × 10 A (T) max. 3 × 20 A
Frequency	50...60 Hz

Output	
Output voltage	24 V DC (SELV), ±1%; 22...28 V adjustable
Output current	5 A (+55 °C); 3 A (+70 °C) 10 A (+55 °C); 6.5 A (+70 °C) 20 A (+55 °C); 15.8 A (+70 °C) 40 A (+55 °C); 30 A (+70 °C)
Power Boost	1.05 N × 150 % (min. 4 s)
Mains failure bridging time	min. 30 ms (400 V AC) min. 19 ms (400 V AC)
Ripple	max. 50 mVrms
Spikes	max. 100 mV p-p
LED display	LED (green): OK; LED (red): overload
Parallel usage/serial usage	max. 5 units/max. 2 units
Alarm output	electronic relay max. 30 V DC/0.1 A, group alarm

General data	
Standards	(EN 60950-1), (EN 61204-3), (EN 55022 B), (EN 61000-3-2) (EN 60950-1), (EN 61204-3), (EN 55011 A)
Relative humidity	5...95 %, no condensation
Protection	Circuit board with protective varnish
Efficiency	86 % 90 %
Mounting method	DIN-rail mountable TH35 (EN 60715)
Protection	IP20
Temperature range	-25...+70 °C (storage temperature -40...+85 °C)

Dimension drawing

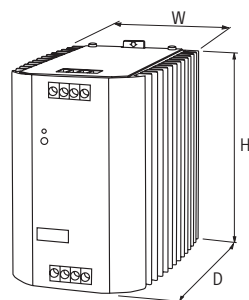

Notes

POWER SUPPLY UNITS

2-/3-phase
 – stable output voltage,
 short-circuit and
 overload protected

Evolution

OUTPUT: 12 V DC \pm 1%
 Current: 20 A



Evolution+

OUTPUT: 48 V DC
 Current: 5 A



Evolution+

OUTPUT: 48 V DC
 Current: 10 A



Evolution+

OUTPUT: 48 V DC
 Current: 20 A



Circuit diagram

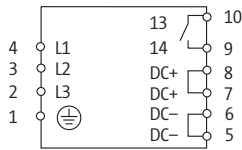

Order Data	H×W×D/kg	Art-No.	H×W×D/kg	Art-No.	H×W×D/kg	Art-No.	H×W×D/kg	Art-No.
12 V DC/20 A	132×93×114/1.3	85016						
48 V DC/5 A			132×93×114/1.4 – UL-Listed	85009				
48 V DC/10 A					132×113×136/2.0 – UL-Listed	85010		
48 V DC/20 A							132×164×142/3.0 – UL-Listed	85011

Input

Input voltage	3 × 324...572 V AC/480...745 V DC			
Input current	3 × 0.8 A		3 × 1.3 A	3 × 1.9 A
Inrush current after 1 ms	max. 15 A	max. 9 A	max. 23 A	–
Primary fusing external	3 × 10 A (T)	max. 3 × 20 A		
Frequency	50...60 Hz			

Output

Output voltage	12 V DC (SELV), \pm 1%; 12...13.5 V adjustable	48 V DC (SELV), \pm 1%; 48...56 V adjustable		
Output current	20 A (+55 °C); 15.8 A (+70 °C)	5 A (+55 °C); 3.73 A (+70 °C)	10 A (+55 °C); 8 A (+70 °C)	20 A (+55 °C); 15 A (+70 °C)
Power Boost	I _{out} N × 150 % (min. 4 s)			
Mains failure bridging time	min. 19 ms (400 V AC)	min. 17 ms (400 V AC)	min. 24 ms (400 V AC)	min. 17 ms (400 V AC)
Ripple	max. 50 mVrms			
Spikes	max. 100 mV p-p			
LED display	LED (green): OK; LED (red): overload			
Parallel usage/serial usage	max. 5 units/max. 4 units	max. 5 units/no		
Alarm output	electronic relay max. 30 V DC/0.1 A, group alarm			

General data

Standards	(EN 60950-1), (EN 61204-3), (EN 55022 B), (EN 61000-3-2)	(EN 60950-1), (EN 61204-3), (EN 55011 A)		
Relative humidity	5...95 %, no condensation			
Efficiency	90 %	91.3 %	92.3 %	92.5 %
Mounting method	DIN-rail mountable TH35 (EN 60715)			
Protection	–	Circuit board with protective varnish		
Protection	IP20			
Temperature range	-25...+70 °C (storage temperature -40...+85 °C)			

Dimension drawing

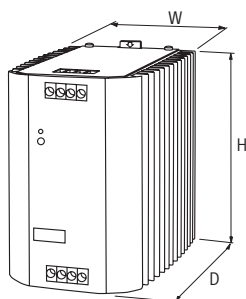

Notes

MICO INTELLIGENT POWER DISTRIBUTION

- Monitor
- Detect
- React

FIRST CLASS POWER DISTRIBUTION

MICO is the intelligent power distribution module from Murrelektronik for 24 VDC. It monitors currents, indicates when approaching the maximum load and make targeted circuit isolations during overload or short circuit conditions. This makes sure systems run at maximum capacity.

EXAMPLE: Why don't circuit breakers trigger reliably in a 24 VDC system?

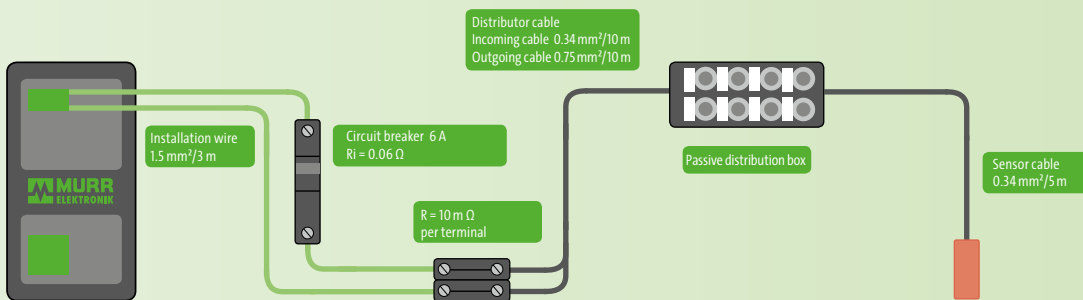

Specific resistance of copper (ρ) = 0.0178 ($\Omega \times \text{mm}^2 / \text{m}$)
 Total loop resistance = 1.32 Ω
 Calculation of maximum current flow $I = \frac{U}{R} = \frac{24 \text{ V}}{1.32 \Omega} = 18.18 \text{ A}$
 (Limited by loop resistance)

Required tripping current for the 6 A type C circuit breaker Tripping current 84 A > max. Current flow 18.18 A

MICO



- MICO+**
- Adjustable current ranges
 - Channels with remote switch on/off function
 - Preventive diagnostics

Page 1.3.1



- MICO CLASSIC**
- Adjustable current ranges
 - Channels with remote switch on function
 - Group alarm output

Page 1.3.3



- MICO BASIC**
- Preset current ranges
 - Small size

Page 1.3.7



- MICO FUSE**
- Socket for glass tube fuses

see onlineshop.murrelektronik.com/en

INTELLIGENT POWER DISTRIBUTION

Over current protection device

- adjustable current ranges
- Early warning (90%)

Approvals:   



MICO+ 4.4

4 channels



MICO+ 4.6

4 channels

Circuit diagram

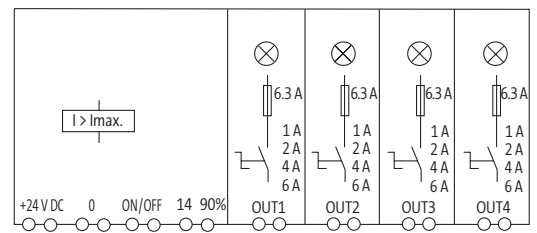
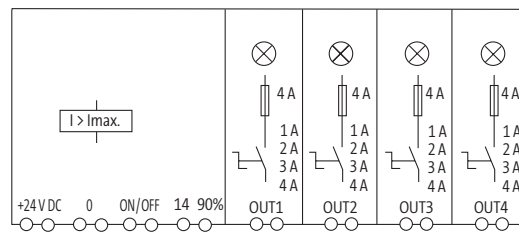

Order Data

1 A, 2 A, 3 A, 4 A

Art-No.

9000-41084-0100400

Art-No.

1 A, 2 A, 4 A, 6 A

9000-41084-0100600

Technical Data

Operating voltage	24 V DC (18...30 V DC)	
Current adjustment	1 A, 2 A, 3 A, 4 A, by countersunk rotary switch, sealed	1 A, 2 A, 4 A, 6 A, by countersunk rotary switch, sealed
Group alarm output	max. 20 mA; high: all channels ON; low: not all channels ON	
Inrush capacity	max. 20 mF (per channel)	
Remote start (ON)	10...30 V DC	
Remote start (OFF)	10...30 V DC	
Impulse length	min. 20 ms	
Early warning (90%)	max. 20 mA; high: one channel over 90%; low: all channels under 90%	

General data

Connection	Spring clamp terminals
Input terminals	2 × 16 mm ²
Output terminals	per output 2 × 1.5 mm ²
Alarm terminals	2.5 mm ²
Bridging concept	two sides, with spring clamp terminals or bridge set (max. 40 A)
Mounting method	DIN-rail mountable TH35 (EN 60715)
Temperature range	0...+55 °C (storage temperature -40...+80 °C)

Dimension drawing

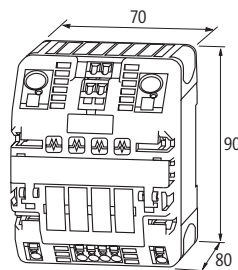

Notes

INTELLIGENT POWER DISTRIBUTION

Over current protection device

- adjustable current ranges
- Early warning (90%)

Approvals:   



MICO+ 4.10

4 channels



Circuit diagram

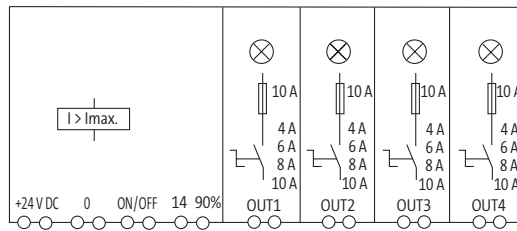

Order Data		Art-No.
4 A, 6 A, 8 A, 10 A		9000-41084-0401000

Technical Data	
Operating voltage	24 V DC (18...30 V DC)
Current adjustment	4 A, 6 A, 8 A, 10 A, by countersunk rotary switch, sealed
Group alarm output	max. 20 mA; high: all channels ON; low: not all channels ON
Inrush capacity	max. 20 mF (per channel)
Remote start (ON)	10...30 V DC
Remote start (OFF)	10...30 V DC
Impulse length	min. 20 ms
Early warning (90%)	max. 20 mA; high: one channel over 90%; low: all channels under 90%

General data	
Connection	Spring clamp terminals
Input terminals	2 × 16 mm ²
Output terminals	per output 2 × 1.5 mm ²
Alarm terminals	2.5 mm ²
Bridging concept	two sides, with spring clamp terminals or bridge set (max. 40 A)
Mounting method	DIN-rail mountable TH35 (EN 60715)
Temperature range	0...+55 °C (storage temperature -40...+80 °C)

Dimension drawing

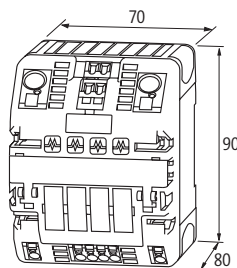

Notes

INTELLIGENT POWER DISTRIBUTION

Over current protection device



MICO 4.4

4 channels



MICO 2.4

2 channels



Circuit diagram

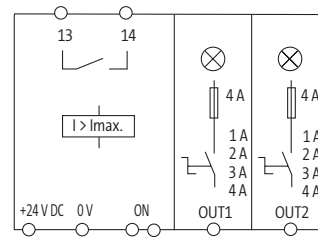
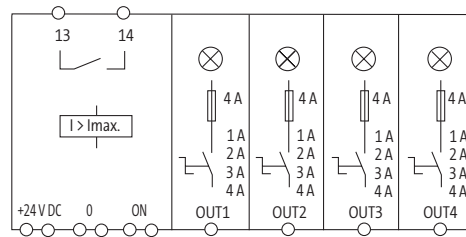

Order Data	Art-No.	Art-No.
1 A, 2 A, 3 A, 4 A	GL	cURus
Technical Data	9000-41034-0100400	9000-41042-0100400
Operating voltage	24 V DC (18...30 V DC)	
Current adjustment	1 A, 2 A, 3 A, 4 A, by countersunk rotary switch, sealed	
Inrush capacity	max. 20 mF (per channel)	
Group alarm output	potential free 30 V AC/DC, 100 mA	
Remote start (ON)	10...30 V DC	
Impulse length	min. 20 ms	
General data		
Connection	Spring clamp terminals	
Input terminals	2 × 16 mm ²	1 × 16 mm ²
Output terminals	per output 1 × 4 mm ²	
Alarm terminals	2.5 mm ²	
Bridging concept	two sides, with spring clamp terminals or bridge set (max. 40 A)	one side, with spring clamp terminals or bridge set (max. 40 A)
Mounting method	DIN-rail mountable TH35 (EN 60715)	
Temperature range	0...+55 °C (storage temperature -40...+80 °C)	
Dimension drawing		

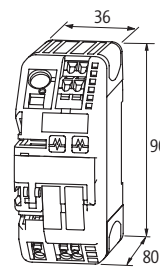
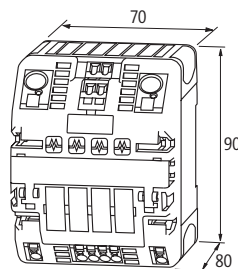

Notes

INTELLIGENT POWER DISTRIBUTION

Over current protection device

MICO 4.6

4 channels



MICO 2.6

2 channels



Approvals:   



Circuit diagram

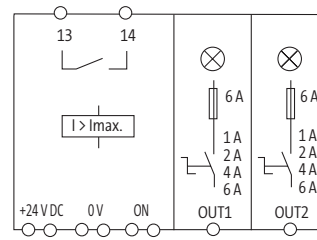
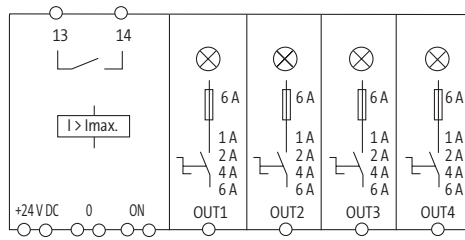

Order Data	Art-No.	Art-No.
1 A, 2 A, 4 A, 6 A	9000-41034-0100600	9000-41042-0100600
Technical Data		
Operating voltage	24 V DC (18...30 V DC)	
Current adjustment	1 A, 2 A, 4 A, 6 A, by countersunk rotary switch, sealed	
Inrush capacity	max. 20 mF (per channel)	
Group alarm output	potential free 30 V AC/DC, 100 mA	
Remote start (ON)	10...30 V DC	
Impulse length	min. 20 ms	
General data		
Connection	Spring clamp terminals	
Input terminals	2 × 16 mm ²	1 × 16 mm ²
Output terminals	per output 1 × 4 mm ²	
Alarm terminals	2.5 mm ²	
Bridging concept	two sides, with spring clamp terminals or bridge set (max. 40 A)	one side, with spring clamp terminals or bridge set (max. 40 A)
Mounting method	DIN-rail mountable TH35 (EN 60715)	
Temperature range	0...+55 °C (storage temperature -40...+80 °C)	
Dimension drawing		

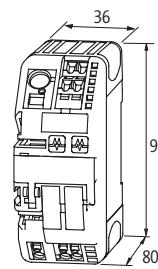
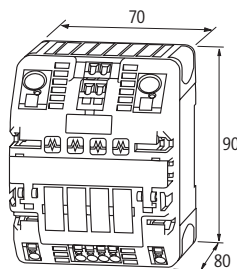

Notes

Over current protection device



MICO 4.10

4 channels



MICO 2.10

2 channels



Circuit diagram

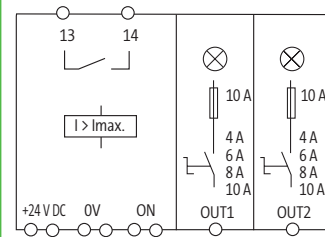
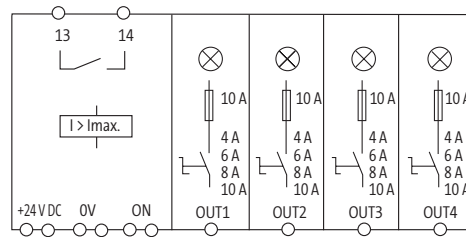

Order Data	Art-No.	Art-No.
4 A, 6 A, 8 A, 10 A	9000-41034-0401000	9000-41042-0401000

Technical Data	GL	cURus
Operating voltage	24 V DC (18...30 V DC)	
Current adjustment	4 A, 6 A, 8 A, 10 A, by countersunk rotary switch, sealed	
Inrush capacity	max. 20 mF (per channel)	
Group alarm output	potential free 30 V AC/DC, 100 mA	
Remote start (ON)	10...30 V DC	
Impulse length	min. 20 ms	
General data		
Connection	Spring clamp terminals	
Input terminals	2 × 16 mm ²	1 × 16 mm ²
Output terminals	per output 1 × 4 mm ²	
Alarm terminals	2.5 mm ²	
Bridging concept	two sides, with spring clamp terminals or bridge set (max. 40 A)	one side, with spring clamp terminals or bridge set (max. 40 A)
Mounting method	DIN-rail mountable TH35 (EN 60715)	
Temperature range	0...+55 °C (storage temperature -40...+80 °C)	

Dimension drawing

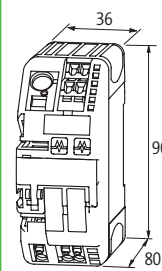
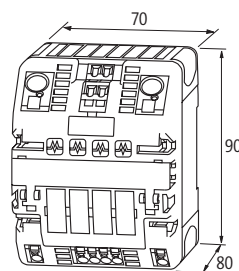

Notes

INTELLIGENT POWER DISTRIBUTION

Over current protection device

MICO 4.4.10 ACTUATOR-SENSOR

MICO 4.10 SPEED START

4 channels
optimized start-up behavior

Approvals:   



Circuit diagram

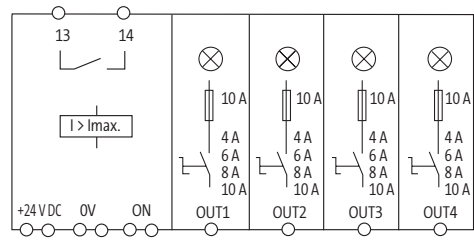
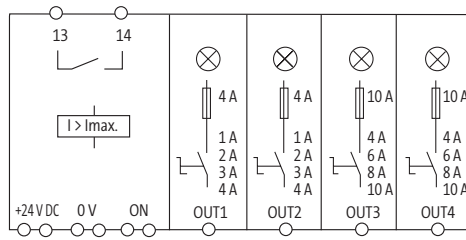

Order Data	Art-No.	Art-No.
1 A, 2 A, 3 A, 4 A; 4 A, 6 A, 8 A, 10 A	9000-41034-0101000	
4 A, 6 A, 8 A, 10 A		9000-41034-0401005

Technical Data

Operating voltage	24 V DC (18...30 V DC)	
Current adjustment	1 A, 2 A, 3 A, 4 A; 4 A, 6 A, 8 A, 10 A, by countersunk rotary switch, sealed	4 A, 6 A, 8 A, 10 A, by countersunk rotary switch, sealed
Inrush capacity	max. 20 mF (per channel)	max. 30 mF (per channel)
Group alarm output	potential free 30 V AC/DC, 100 mA	
Remote start (ON)	10...30 V DC	
Impulse length	min. 20 ms	

General data

Connection	Spring clamp terminals
Input terminals	2 × 16 mm ²
Output terminals	per output 1 × 4 mm ²
Alarm terminals	2.5 mm ²
Bridging concept	two sides, with spring clamp terminals or bridge set (max. 40 A)
Mounting method	DIN-rail mountable TH35 (EN 60715)
Temperature range	0...+55 °C (storage temperature -40...+80 °C)

Dimension drawing

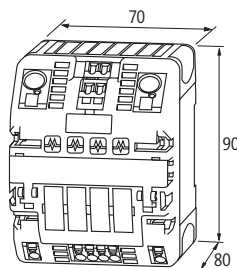

Notes

Over current protection device

– preset tripping current

Approvals:



MICO BASIC 8.2

8 channels



MICO BASIC 8.4

8 channels

MICO BASIC 8.6

8 channels

Circuit diagram

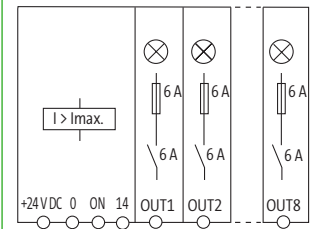
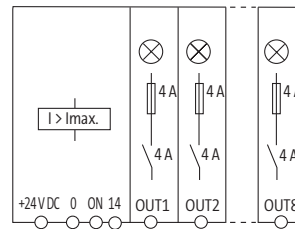
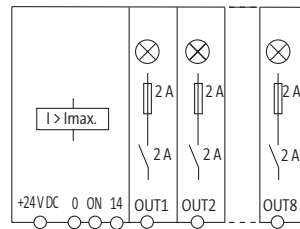

Order Data	Art-No.	Art-No.	Art-No.
2 A	9000-41068-0200000		
4 A		9000-41068-0400000	
6 A			9000-41068-0600000

Technical Data			
Operating voltage	24 V DC (18...30 V DC)		
Current adjustment	2 A	4 A	6 A
Group alarm output	max. 20 mA; high: all channels ON; low: not all channels ON		
Inrush capacity	max. 20 mF (per channel)		
Remote start (ON)	10...30 V DC		
Impulse length	min. 20 ms		

General data	
Input terminals	1 × 16 mm ²
Output terminals	per output 1 × 4 mm ²
Alarm terminals	2.5 mm ²
Bridging concept	one side, with spring clamp terminals or bridge set (max. 40 A)
Connection	Spring clamp terminals
Mounting method	DIN-rail mountable TH35 (EN 60715)
Temperature range	0...+55 °C (storage temperature -40...+80 °C)

Dimension drawing

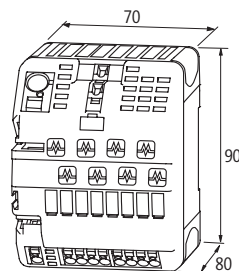

Notes

INTELLIGENT POWER DISTRIBUTION

Over current protection device

– preset tripping current

Approvals:  



MICO BASIC 4.2

4 channels



MICO BASIC 4.4

4 channels

MICO BASIC 4.6

4 channels

Circuit diagram

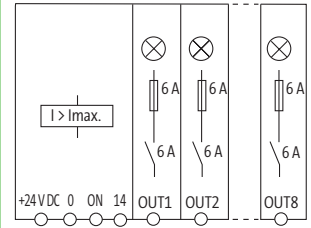
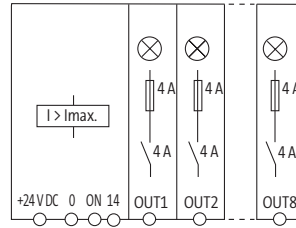
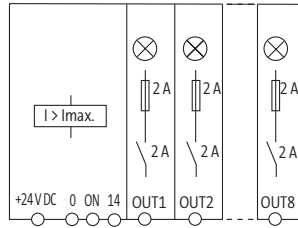

Order Data	Art-No.	Art-No.	Art-No.
2 A	9000-41064-0200000		
4 A		9000-41064-0400000	
6 A			9000-41064-0600000

Technical Data

Operating voltage	24 V DC (18...30 V DC)		
Current adjustment	2 A	4 A	6 A
Inrush capacity	max. 20 mF (per channel)		
Group alarm output	max. 20 mA; high: all channels ON; low: not all channels ON		
Remote start (ON)	10...30 V DC		
Impulse length	min. 20 ms		

General data

Connection	Spring clamp terminals		
Input terminals	1 × 16 mm ²		
Output terminals	per output 1 × 4 mm ²		
Alarm terminals	2.5 mm ²		
Bridging concept	one side, with spring clamp terminals or bridge set (max. 40 A)		
Mounting method	DIN-rail mountable TH35 (EN 60715)		
Temperature range	0...+55 °C (storage temperature -40...+80 °C)		

Dimension drawing

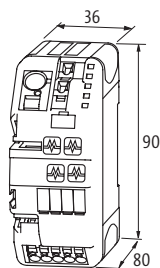

Notes

INTELLIGENT POWER DISTRIBUTION

Over current protection device

– preset tripping current

Approvals: 

MICO BASIC 5.2/3.6

8 channels



Circuit diagram

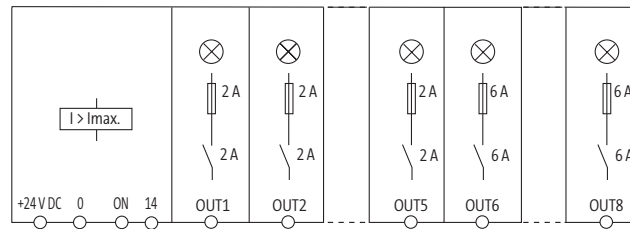

Order Data

5 × 2 A; 3 × 6 A

Art-No.

9000-41068-0200600

Technical Data

Operating voltage	24 V DC (18...30 V DC)
Current adjustment	5 × 2 A; 3 × 6 A
Inrush capacity	max. 20 mF (per channel)
Group alarm output	max. 20 mA; high: all channels ON; low: not all channels ON
Remote start (ON)	10...30 V DC
Impulse length	min. 20 ms

General data

Connection	Spring clamp terminals
Input terminals	1 × 16 mm ²
Output terminals	per output 1 × 4 mm ²
Alarm terminals	2.5 mm ²
Bridging concept	one side, with spring clamp terminals or bridge set (max. 40 A)
Mounting method	DIN-rail mountable TH35 (EN 60715)
Temperature range	0...+55 °C (storage temperature -40...+80 °C)

Dimension drawing

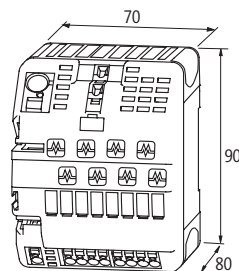

Notes



EMC FILTERS FOR MAXIMUM SAFETY

- Meets EMC guidelines
- Increases interference protection
- Decreases interference emissions

KEEP IT SAFE – EVEN IN THE CONTROL CABINETS

Mains filters are used to reduce interference without affecting the supply. Murrelektronik's filters decrease incoming interference, which can affect sensitive equipment, and also decrease outgoing interference from the equipment they are connected to, which could damage the mains supply. Typical sources of continuous interference are switch mode power supplies, motors and phase controllers.

These sources are made up of inductive and capacitive components and work the best when their impedance is matched to the source of the interference. In regards to grounding, it's important to have a low impedance. Ideally, the filter should be as close as possible to the point where the cable enters the cabinet. If that's not possible, then shielded cables should be used between the filter and the entry point. Ground straps should be as short as possible and connection surfaces should be free from paint, etc.

Single-phase



MEF 1/1 – one-stage

- Operating voltage: max. 250 V AC/DC, 0..60 Hz
- Nominal current: 10...20 A

Page 1.4.1



MEF 1/2 SY and MEF 1/2 AS – two-stage

- Operating voltage: max. 250 V AC/DC, 0..60 Hz
- Nominal current: 10...16 A

see onlineshop.murrelektronik.com/en

Three-phase



MEF 3/1 N – one-stage

- Operating voltage: max. 3 x 440 V AC
- Nominal current: 3...20 A

Page 1.4.2



MEF 3/1 N HD – one-stage

- Operating voltage: max. 3 x 500 V AC
- Nominal current: 10...135 A

see onlineshop.murrelektronik.com/en



MEF 3/1 and MEF 3/2 – one and two-stage

- Operating voltage: max. 3 x 500 V AC / 3 x 600 V AC
- Nominal current: 8...180 A

see onlineshop.murrelektronik.com/en

EMC FILTERS

1-phase, 1-stage

– DIN-rail mountable

Approvals:  

MEF 1/1
for universal applications



Circuit diagram

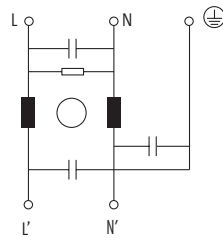

Order Data

	Art-No.
10 A	10415
20 A	10416

Technical Data

Operating voltage	max. 250 V AC/300 V DC
Operating frequency	50...60 Hz
Consumption at 250 V AC	max. 5 mA
Overload current	18 × (IN t) max. 0.5 ms; 1.5 × (IN t) max. 1 min. (1 × per hour)

General data

Climatic category	25/085/21 (EN 60068-1)
Test isolation voltage	2.7 kV (L - N), 2 s; 2.1 kV (L - L), 2 s (EN 60939-2)
Connection	Screw connection, touch protected
Mounting method	DIN-rail mountable TH35 (EN 60715)

Dimension drawing

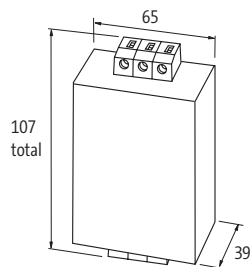

Notes

EMC FILTERS

3-phase, 1-stage

– DIN-rail mountable

– with neutral

Approvals:  

MEF 3/1 N

for universal applications



Circuit diagram

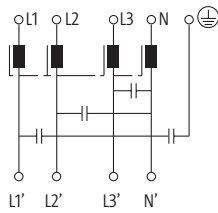

Order Data	Art-No.
3 A	10510
6 A	10511
10 A	10512
20 A	10513

Technical Data	
Operating voltage	max. 4 × 440 V AC
Operating frequency	50...60 Hz
Consumption at 250 V AC	max. 3 mA
Overload current	18 × (IN t) max. 0.5 ms; 1.5 × (IN t) max. 1 min. (1 × per hour)

General data	
Climatic category	25/085/21 (EN 60068-1)
Test isolation voltage	2.7 kV (L - N), 2 s; 2.1 kV (L - L), 2 s (EN 60939-2)
Connection	Screw connection, touch protected
Mounting method	DIN-rail mountable TH35 (EN 60715)

Description	
Functional description	The 3-phase and one-stage EMC filters MEF 3/1 are used in the range 0.1...30 MHz and dampen interferences found in cables from the mains, supply units and control systems. They are suitable for TN-S, TN-C-S, and TT networks. The best results are obtained with short connection cables (suggestion: earth connection < 10 cm) of the largest possible cross-section. The EMC filters are bi-directional. They reduce symmetrical and asymmetrical interferences that regularly appear with electronically controlled three phase units through mains influences.

Dimension drawing

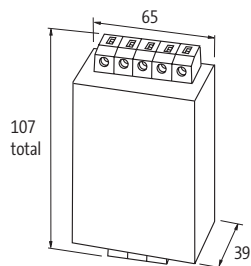

Notes

Suppressors

– universal

A0

AD

CF



Approvals:



Circuit diagram

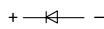

Diode

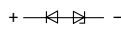

Diode/Z-Diode

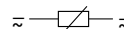

VDR

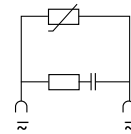

VDR-RC

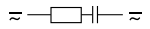

RC

Appropriate contactors

universal

universal

universal

Ordering data

Ordering data		Art.-No.	Art.-No.	Art.-No.	sugg. coil valves		
Voltage	Suppression	Approval	Approval	Approval	A0	AD	CF
Max. 240 V DC	Diode	CSA 26001			15 W		
24 V DC	Z-Diode	CSA 26120	CSA 26073		25 W	75 W	
24 V AC/DC	VDR	cURus / CSA 26180	CSA 26720		50 VA/W	200 VA/W	
	RC			CSA 20680			20 VA
48 V AC/DC	VDR	cURus / CSA 26181			70 VA/W		
	RC	cURus / CSA 20001	cURus / CSA 20013		15 VA	15 VA	
110 V AC/DC	VDR	cURus / CSA 26182	CSA 26722		100 VA/W	200 VA/W	
	VDR-RC						
	RC						
230 V AC/DC	VDR	cURus / CSA 26183	CSA 26723		200 VA/W	200 VA/W	
	VDR	cURus / CSA 26184			200 VA/W		
	RC		CSA 20014	CSA 20682		25 VA	20 VA
	RC	cURus / CSA 20002	cURus / CSA 20010	CSA 20683	15 VA	75 VA	20 VA
	RC		cURus / CSA 20011	CSA 20687		100 VA	50 VA
400 V AC/DC	VDR		CSA 26724			200 VA/W	
	RC	cURus / CSA 20004	cURus / CSA 20012	CSA 20688	15 VA	100 VA	50 VA
	RC						

Technical data

Damping factor	ca. 1,5
Temperature range	-20...+70 °C
Material	plastic, flame retardant (UL 94)
Connection wires	self-securing cable forks

Dimension drawing

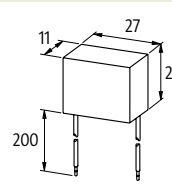
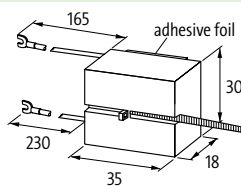
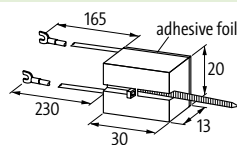

Form 1

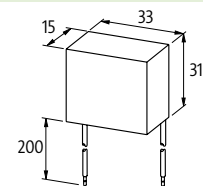

²⁾ Form 2

Notes

Art.-No. 26184 – up to 300 V AC/DC

EMC SUPPRESSORS

Suppressors

– universal

Approvals:



H



RC-BUG 2



BU + UB



Circuit diagram

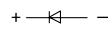

Diode

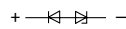

Diode/Z-Diode

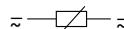

VDR

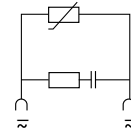

VDR-RC

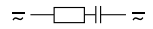

RC

Appropriate contactors

universal

universal

universal

Ordering data

Ordering data		Art.-No.	Art.-No.	Art.-No.	sugg. coil valves		
Voltage	Suppression	Approval	Approval	Approval	H	RC-BUG 2	BU + UB
24 ...240 V DC	Diode	CSA 26097		CSA 26020	25 W		50 W
24 V DC	Z-Diode	CSA 26095		CSA 26130	25 W		50 W
24 V AC/DC	VDR	cURus / CSA 26090		cURus / CSA 26150	50 VA/W		50 VA/W
	RC						
48 V AC/DC	VDR						
	RC	CSA 20100			15 VA		
110 V AC/DC	VDR						
	VDR-RC						
	RC		CSA 26613			146 VA	
230 V AC/DC	VDR						
	VDR		CSA 26619	cURus / CSA 26155		100 VA/W	200 VA/W
	RC	CSA 20101	CSA 26614	CSA 20031	15 VA	146 VA	25 VA
	RC	CSA 20102		CSA 20033	25 VA		25 VA
	RC	CSA 20103		CSA 20034	75 VA		25 VA
400 V AC/DC	VDR						
	RC		CSA 26615	CSA 20032		146 VA	25 VA
	RC		CSA 26616			146 VA	

Technical data

Damping factor	ca. 1,5
Temperature range	-20...+70 °C
Material	plastic, flame retardant (UL 94)
Mounting method	DIN-rail mounting (EN 60715) with adapter ASA Art.-No. 20900, DIN-rail mounting (EN 60715)
Connection wires	self-securing cable forks

Dimension drawing

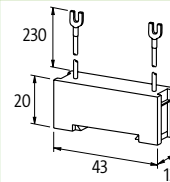
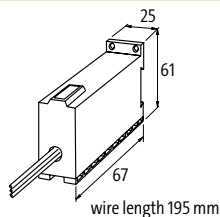
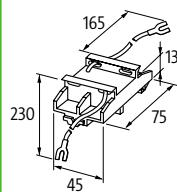

Notes

Art.-No. 20034 – without adapter, can be directly snapped onto DIN-rail, ASA adapter Art.-No. 20900 included in delivery.
Art.-No. 26616 – up to 600 V AC/DC

EMC Suppressors

EMC SUPPRESSORS

Suppressors for motors

Mounting methods:

- on the motor terminal box
- inside the motor terminal box
- inside the distribution box
- on 35 mm DIN-rail acc. to EN 60715

Approvals:



RC 3 U

With M16 x 1,5



RC 3 BU



RC 3 BUG



Circuit diagram

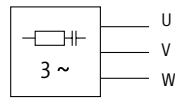

RC

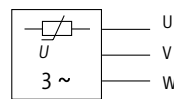

VDR

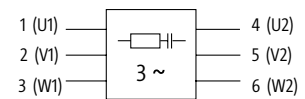

RC(1) per phase

Ordering data		Art.-No.	Art.-No.	Art.-No.
Voltage	Motor rating	Suppression/Approval	Suppression/Approval	Suppression/Approval
3 x 400 V AC	4 kW	RC	23022	RC/cURus 23050
	4 kW			VDR 23115
	4 kW			VDR/cURus 23115
	7,5 kW			VDR/cURus 23115
	10 kW	RC	23011	VDR/cURus 23118
	10 kW	RC-per phase	23043	
	20 kW			VDR/cURus 23118
3 x 575 V AC	4 kW			RC/cURus 23050
	7,5 kW	RC/cURus	23035	RC 23104
	20 kW			VDR 23102
	45 kW			RC-per phase 23103
3 x 690 V AC	4 kW			RC/v 23056
	7,5 kW			RC 23104
	20 kW			RC 23104

Technical data

Frequency	for RC: 50...60 Hz		for VDR: 10...400 Hz
Material	plastic, flame retardant (UL 94)		
Potting compound	2-component epoxy		
Temperature range	-20...+60 °C		
Connection method	approx. 500 mm PVC cable 3 x 0,75 mm ² or 7 x 0,75 mm ²	approx. 200 mm single core 0,35 mm ² ; Art.-No. 23056 0,5 mm ² with self-securing M4 cable forks M4	approx. 500 mm single core 1 mm ²

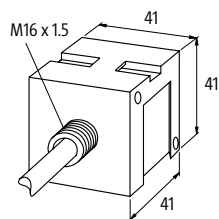

For DIN-rail mounting use
2 x **Art.-No. 20900** adapter feet

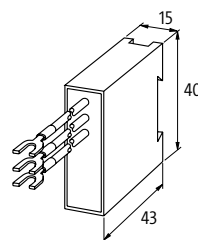

For DIN-rail mounting use
1 x **Art.-No. 20900** adapter feet

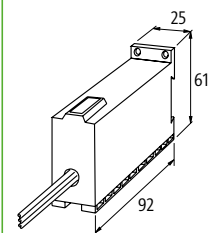

For DIN-rail mounting use
2 x **Art.-No. 20900** adapter feet

Notes

Do not use RC motor suppressors on variable frequency drives.
1 x **Art.-No. 23103, 23043** required per phase.

EMC SUPPRESSORS

Suppressors for motors

Mounting methods:

- with M16 x 1.5 and M20 x 1.5
- on the motor terminal box with plug connectors

Approvals:



RC 3 R

With M16 x 1.5 screw



RC 3 R

With M16 x 1.5 screw

RC 3 RG

With M20 x 1.5 screw



Circuit diagram

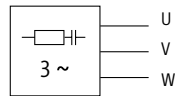

RC

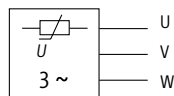

VDR

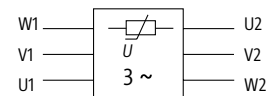

VDR-(1) per phase

Ordering data

Ordering data		Art.-No.	Art.-No.	Art.-No.
3 x 400 V AC	Motor rating	Suppression/Approval	Suppression/Approval	Suppression/Approval
	4 kW	VDR/cURus	23170	RC/cURus
	4 kW			
	4 kW			
	7,5 kW	VDR	23171	
	10 kW			VDR
3 x 575 V AC	20 kW			23142
	4 kW	VDR/cURus	23172	VDR
	7,5 kW	VDR/cURus	23173	23144
	10 kW			RC/cURus
	20 kW			23141
	20 kW			VDR/cURus
3 x 690 V AC	7,5 kW	VDR	23174	23145
	20 kW			VDR/cURus
	20 kW			23146
	20 kW			VDR per phase
				23147
				VDR
				23149

Technical data

Frequency	for RC: 50...60 Hz		for VDR: 10...400 Hz
Material	plastic, flame retardant (UL 94)		
Potting compound	2-component epoxy		
Temperature range	-20...+60 °C		
Connection method	approx. 100 mm single core 0,5 mm ²		approx. 150 mm single core 1 mm ²
Ring terminals	isolated M6	isolated M4	isolated M6

Dimension drawing

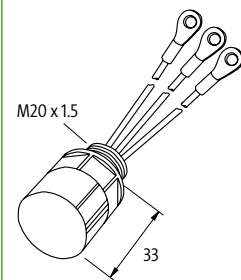
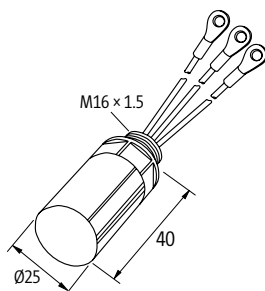

Notes

Do not use RC motor suppressors on variable frequency drives.

Art.-No. 23174 – wire diameter 1.5 mm².

RELAYS / SAFETY RELAYS INCREDIBLY VERSATILE

- Over 600 different modules ready for all applications
- Push-In technology, spring clamps or screw terminals available
- Worldwide approvals

TWICE AS SMALL, TWICE AS FAST!

Each system includes different kinds of active interface modules. Relay modules are used to separate two different potential levels. The control side is galvanically isolated from the load/contact side and should be protected from the wrong voltage. These interfaces adjust the different signal levels to work with the existing system.

With MIRO SAFE+, Murrelektronik offers safe switching devices for a wide range of safe industrial applications. They are the perfect solution to reach high safety standards – up to performance level e (PLe) according to EN 13849-1. **With MIRO SAFE+ you can design many different safety applications like: emergency stops, guard doors, two hand monitoring, light curtains, and safety magnet switch monitoring.**

Relays



- Relay 6.2 mm**
- Output relay
 - Input relay

Page 1.6.1



- Relay 12.4 mm**
- Output relay
 - Input relay

see onlineshop.murrelektronik.com/en



- Relay 22.5 mm**
- Output relay
 - Input relay

Page 1.6.3



Accessories

see onlineshop.murrelektronik.com/en

Safety Relays



- Safety Relay 22.5 / 45 mm**
- MIRO SAFE+

Page 1.6.4

RELAYS / SAFETY RELAYS

Terminal relay

– with bridge system

Approvals:   

MIRO 6.2

Output relay
1 NO/NC contact
Screw terminals



MIRO 6.2

Output relay
1 NO/NC contact
Spring clamp terminals



MIRO 6.2

Output relay
1 NO contact
Screw terminals



MIRO 6.2

Output relay
1 NO contact
Spring clamp terminals



Circuit diagram

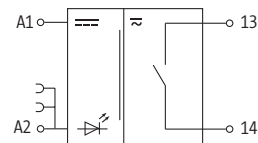
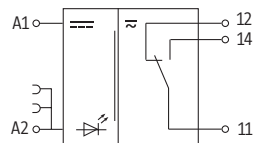

Order Data

	Art-No.	Art-No.	Art-No.	Art-No.
12 V DC (10...15 V DC) - 20 mA	52050	6652050		
24 V DC (19.2...30 V DC) - 14 mA	CCC 52000	CCC 6652000	CCC 52002	CCC 6652002
24 V DC (19.2...30 V DC) - 17 mA	CCC 52001	CCC 6652001	CCC 52015	CCC 6652015

Utilization category

AC-12	6 A (24/110/230 V AC)
AC-15	3 A (24/110/230 V AC)
DC-13	1 A (24 V DC); 0.2 A (110 V DC); 0.1 A (230 V DC)

Input

LED display	LED (green)
-------------	-------------

Output

Switching voltage	max. 250 V AC/DC
Switching current per output	max. 6 A
Min. load current	10 mA (12 V DC) 100 mA (12 V DC)
Power rating (voltage dependent)	max. 1500 VA/120 W
Switching frequency	max. 10 Hz
Contact material	Ag Sn O2
Energize/release/contact bounce time	10/15/1.5 ms

General data

Mech./ elect. life	20.000.000 switching cycles/load dependent
Test isolation voltage	4 kV; safe separation (EN 60947-1)
Mounting method	DIN-rail mountable (EN 60715)
Temperature range	-20...+55 °C

Dimension drawing

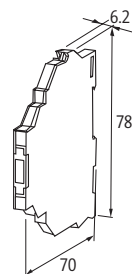
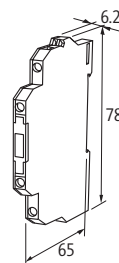
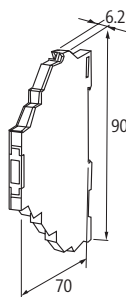
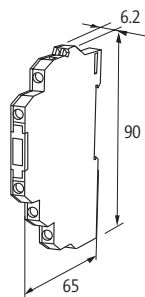

Notes

For inductive loads we recommend EMC suppressors connected parallel to the coil

RELAYS / SAFETY RELAYS

Terminal relay

MIRO 6.2

Input relay
1 NO/NC contact
Screw terminals



MIRO 6.2

Input relay
1 NO/NC contact
Spring clamp terminals



Approvals:

Circuit diagram

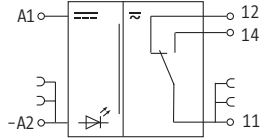

Order Data	Art-No.	Art-No.
24 V DC (19.2...30 V DC) - 14 mA	52005	6652005
24 VAC/DC (19.2...30 VAC/DC) - 17mA	52003	6652003

Utilization category

AC-12	6 A (24/110/230 V AC)
AC-15	3 A (24/110/230 V AC)
DC-13	1 A (24 V DC); 0.2 A (110 V DC); 0.1 A (230 V DC)

Input	Output
LED display	LED (yellow)
Switching voltage	max. 30 V AC/36 V DC
Switching current per output	max. 6 A
Switching current per output (Signal)	max. 20 mA
Min. load current	1 mA (12 V DC)
Power rating (voltage dependent)	max. 1500 VA/120 W
Switching frequency	max. 10 Hz
Contact material	Ag Sn O2 hv
Energize/release/contact bounce time	10/15/1.5 ms

General data

Mech./ elect. life	20.000.000 switching cycles/load dependent
Test isolation voltage	4 kV; safe separation (EN 60947-1)
Mounting method	DIN-rail mountable (EN 60715)
Temperature range	-20...+55 °C

Dimension drawing

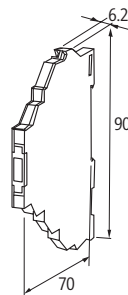
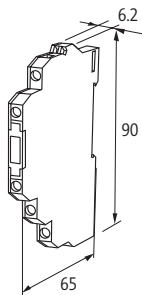

Notes

For inductive loads we recommend EMC suppressors connected parallel to the coil. When the max. switching voltage/current is exceeded the gold plating is destroyed. The relay will then take on the properties of an output type.

RELAYS / SAFETY RELAYS

Relays

– Screw terminals

RM

Output relay
3 relays; each 1 NO/NC contact



RM

Output relay
4 relays; each 1 NO contact

Circuit diagram

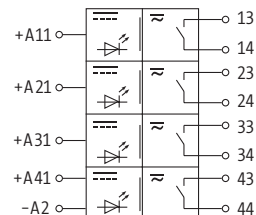
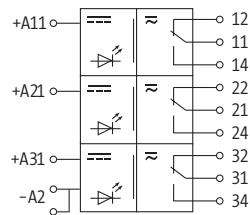

Order Data

24 V DC (19.2...30 V DC) - 16 mA

Art-No.

51403

Art-No.

512498

Utilization category

AC-1	8 A (24/110/230 V AC)
AC-15	3 A (24/110/230 V AC)
DC-13	1.5 A (24 V DC); 0.3 A (110 V DC); 0.15 A (230 V DC)

Input

LED display LED (red)

Output

Switching voltage	max. 250 V AC/DC	
Switching current per output	max. 8 A	max. 5 A
Min. load current	100 mA	
Power rating (voltage dependent)	max. 1250 VA/240 W	
Switching frequency	max. 0.1 Hz (with load)	
Contact material	Ag Sn O2	Ag hv
Energize/release/contact bounce time	10/10/2 ms	

General data

Mech./ elect. life	20.000.000 switching cycles/load dependent	50.000.000 switching cycles/load dependent
Test isolation voltage	4 kV	
Mounting method	DIN-rail mountable TH35 or G32 (EN 60715)	
Temperature range	-20...+50 °C	

Dimension drawing

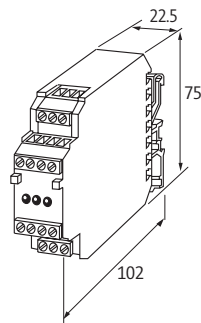

Notes

RELAYS / SAFETY RELAYS

Safety relay

- Protection-door and emergency-stop control
- Light curtain control
- Safety magnetic switch control

Approvals:  Listed

MIRO SAFE+ Switch H L 24

with/without start button monitoring



Circuit diagram

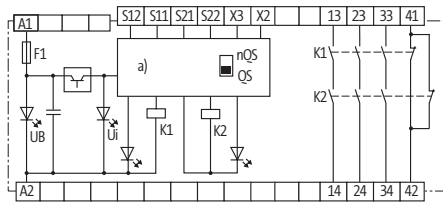

Order Data		Art-No.
3 safety contacts		3000-33113-3020012
Utilization category		
Safety contacts (STOP 0)	max. 250 V AC/8 A; min. 10 V AC/10 mA (ohm./ind.), at suitable suppression	
AC-15	6 A (230 V AC) STOPO	
DC-13	6 A (24 V DC) STOPO	
Safety Indicators		
PL	up to e	
Category	up to 4	
DC	99 %	
SIL	up to 3	
Service life	20 years	
Input		
Input voltage	24 V DC (-15/+20 %), 24 V AC (-15/+10 %)	
Input current	max. 4.9 VA/2.0 W	
Output		
Switching voltage	max. 250 V AC/DC	
Switching current per output	max. 8 A	
Total current	24 A (45 °C); 18 A (55 °C); 12 A (60 °C)	
Number of auxiliary contacts	1 - (41-42)	
Number of alarm outputs	0	
Number of safety contacts	3 - (13-14); (23-24); (33-34)	
Contact material	AgSnO, self cleaning, positively driven	
General data		
Mech./ elect. life	10.000.000 switching cycles/load dependent	
Mounting method	DIN-rail mountable (EN 60715)	
Temperature range	-25...+60 °C (storage temperature -40...+85 °C)	
Dimension drawing		

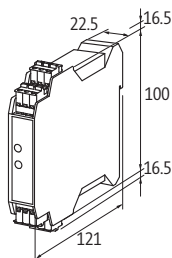

Notes

RELAYS / SAFETY RELAYS

Safety relay

- Protection-door and emergency-stop control
- Light curtain control
- Safety magnetic switch control

Approvals:  UL_{US}
Listed

MIRO SAFE+ Switch ECOA 24

without start button monitoring



Circuit diagram

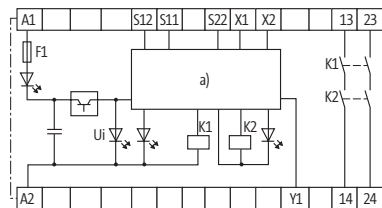

Order Data

2 safety contacts

Art-No.

3000-33113-3020005

Utilization category

Safety contacts (STOP 0)

max. 250 V AC/4 A; min. 5 V AC/1 mA (ohm./ind.), at suitable suppression

AC-15

2 A (230 V AC) STOP0

DC-13

1 A (24 V DC) STOP0

Alarm outputs

100 mA (24 V DC)

Safety Indicators

PL

up to 4

Category

–

DC

–

SIL

–

Service life

–

Input

Input voltage

24 V DC (-15/+20 %), 24 V AC (-15/+10 %)

Input current

max. 5.2 VA/2.0 W

Output

Switching voltage

max. 250 V AC/DC

Switching current per output

max. 4 A

Number of auxiliary contacts

0

Number of alarm outputs

1 - (Y1)

Number of safety contacts

2 - (13-14; 23-24)

Contact material

AgSnO, self cleaning, positively driven

General data

Mech./ elect. life

10.000.000 switching cycles/load dependent

Connection

Screw terminals

Mounting method

DIN-rail mountable (EN 60715)

Temperature range

-25...+60 °C (storage temperature -40...+85 °C)

Dimension drawing

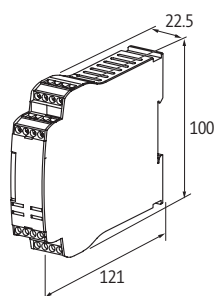

Notes



OPTOCOUPERS / SEMICONDUCTORS SWITCHING WITHOUT WEAR

- Shortest possible switching times
- High switching frequencies
- Resistant to EMC interference

MILLIONS OF SWITCHING CYCLES – EVEN WITH HIGH FREQUENCIES

Optocouplers and semiconductors are used to combine different signal levels or to isolate one signal from another. They are similar to a relay interface because they provide an optoelectronic signal transfer between input and output.

Optocouplers and semiconductors have a long life span because they don't have any mechanical components that could wear out. They are suitable for applications with high switching frequencies, even over a long time.

Some benefits of optocouplers and semiconductors:

- Silent operation
- No contact bounce
- Galvanic separation between input and output
- High resistance to shock and vibration
- High switching currents
- Low input power

Optocouplers / Semiconductors



Optocouplers
• DC applications

Page 1.7.1



Semiconductors
• AC applications

see onlineshop.murrelektronik.com/en

Terminal optocoupler

– with bridge system

MIRO 6.2

Transistor 2 A
Screw terminals



MIRO 6.2

Transistor 2 A
Spring clamp terminals



MIRO 6.2

Transistor 2 A
Screw terminals



MIRO 6.2

Transistor 2 A
Spring clamp terminals



Approvals:

Circuit diagram

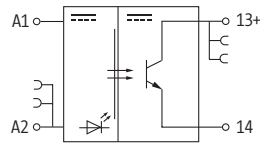

Order Data	Art-No.	Art-No.	Art-No.	Art-No.
24 V DC/6 mA	52501	6652501		
48 V DC/6 mA			52505	6652505
Input				
Voltage range ON	10...48 V DC		18...56 V DC	
Voltage range OFF	0...5 V DC		0...12 V DC	
Control current	6 mA			
LED display	LED (yellow)			
Output				
Switching voltage	5...48 V DC			
Switching current per output	1 mA...2 A			
Saturation voltage (across output)	max. 0.3 V DC			
Leakage current (output is open)	max. 10 µA			
Switching time ON/OFF	1/5 ms			
Switching frequency	max. 10/1 Hz (resist./ind.)			
General data				
Test isolation voltage	2.5 kV			
Mounting method	DIN-rail mountable (EN 60715)			
Housing	Black plastic, flame retardant			
Temperature range	-20...+60 °C			
Dimension drawing				

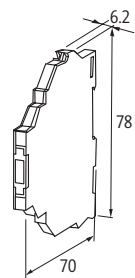
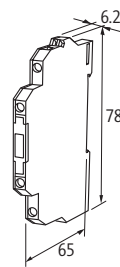
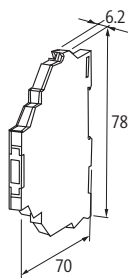
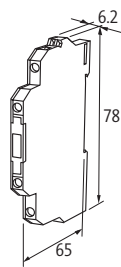

Notes

OPTOCOUPLEDERS / SEMICONDUCTORS

Terminal optocoupler

– with bridge system



MIRO 6.2

Transistor 6 A
Screw terminals



MIRO 6.2

Transistor 6 A
Spring clamp terminals



MIRO 6.2

Transistor 10 A
Screw terminals



MIRO 6.2

Transistor 10 A
Spring clamp terminals



Circuit diagram

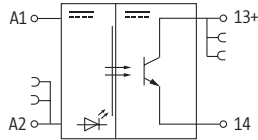

Order Data	Art-No.	Art-No.	Art-No.	Art-No.
24 V DC/6 mA	cURus	52519	6652519	
24 V DC/10 mA			cURus	52520
				6652520

Input

Voltage range ON	10...53 V DC	
Voltage range OFF	0...5 V DC	
Control current	approx. 10 mA	10 mA
LED display	LED (yellow)	

Output

Switching voltage	5...48 V DC	
Switching current per output	1 mA...6 A (without derating)	1 mA...10 A
Saturation voltage (across output)	max. 0.1 V DC	max. 0.12 V DC
Leakage current (output is open)	max. 25 μ A	
Switching time ON/OFF	2/5 ms	2/5 ms (10 A load)
Switching frequency	max. 1/0.1 Hz (resist./ind.)	

General data

Test isolation voltage	2.75 kV
Mounting method	DIN-rail mountable (EN 60715)
Housing	Black plastic, flame retardant
Temperature range	-20...+60 °C

Dimension drawing

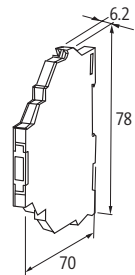
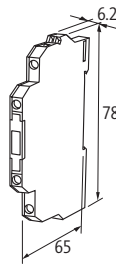
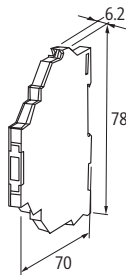
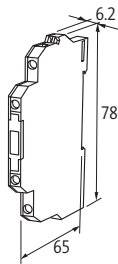

Notes



ACTIVE INTERFACE TECHNOLOGY ANALOG AND DIGITAL

- Solid state or relay outputs are short circuit protected
- LED display
- DIN rail mounting

CONVERT MEASURED VALUES INTO SIGNALS

While measuring, positioning or checking systems, the status of the machine or installation should be monitored. The measured values have to be converted into digital or standard signals (0...20 mA, 4...20 mA or 0...10V) so that PLCs and computers can process them.

Murrelektronik offers a wide range of intelligent interface modules that enable signal conversion or signal acquisition with galvanic separation.

Active Interface Technology



Converters

AD/DA converters, Analog converters, Frequency converters, U/I converters

see onlineshop.murrelektronik.com/en



Timer

MIRO 6.2 Timer

see onlineshop.murrelektronik.com/en



Comparator modules

MAK

see onlineshop.murrelektronik.com/en



Temperature converter

MTW

see onlineshop.murrelektronik.com/en



Switches

Tree

Page 1.8.1



Further

Brake rectifiers, Demagnetizer, MIRO GSM

see onlineshop.murrelektronik.com/en

ACTIVE INTERFACE TECHNOLOGY

Switches

– unmanaged

– RJ45

Approvals:  **UL** us
Listed

Tree 6TX Eco

6 ports



Tree 8TX Metal

8 ports



Tree 6TX Metal

6 ports



Order Data	Art-No.	Art-No.	Art-No.
6 ports	58170		58172
8 ports		58171	
Connections			
Fieldbus	6 x RJ45	8 x RJ45	6 x RJ45
Supply System	Screw plug-in terminal: 0.2...1.5 mm ²		
Technical Data			
Operating voltage	2 x 9...30 V DC, redundancy	2 x 9...48 V DC, redundancy	2 x 9...30 V DC, redundancy
Transfer rate	10/100 Mbit/s full duplex		
Operating modes	Autocrossing Autonegotiation		
Diagnostic			
Communication status	via LED		
Monitoring - no voltage	yes		
General data			
Protection	IP20	IP50	
Housing	Black plastic	Metal black	
Mounting method	DIN-rail mountable TH35 (EN 60715)		
Temperature range	0...+60 °C (storage temperature -10...+70 °C)	-10...+70 °C (storage temperature -40...+85 °C)	
Dimension drawing			

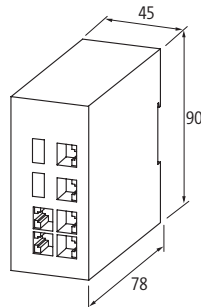

Notes



MODLINK MSDD FRONT PANEL INTERFACES

- PLC Service Port
- IP65 Protection
- Modular Inserts

DESIGN YOUR OWN PART – WITH OUR ARTICLE NUMBERS

The article numbers help you figure out whether you are ordering outlets, data connector inserts, individual frames or sets. The article numbers of the individual components can be found on the following pages. Both modules and sets can be ordered in quantities of 1 or more.

THE SET

The set article number is made up of A, B, C and D.

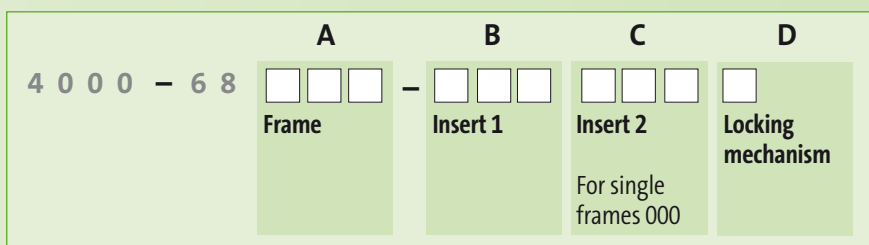

First select your components:

- Block A:** Frame (for example 4000-68**522**-000 0001 for transparent double frame)
- Block B:** Insert 1 (for example 4000-68000-**001** 0000 for Germany (VDE) gray)
- Block C:** Insert 2 (for example 4000-68000-**091** 0000 for 2x RJ45 + 2x USB)
- Block D:** Locking mechan. (for example 4000-68522-000 000**1** for 3 mm double-bit key)

The article number for this example set will be:

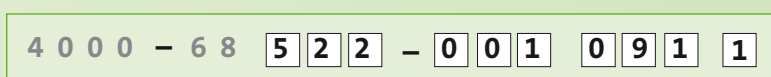

Modlink MSDD Front Panel Interfaces

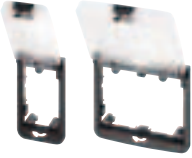

Frames

- Single and double frames

Page 2.1.1



Inserts

- Power outlets
- Data connection inserts

Page 2.1.2



Built-in Sockets

- USB
- RJ45



Page 2.1.4









Accessories

see onlineshop.murrelektronik.com/en







FRONT PANEL INTERFACES

Frames (plastic)			Art-No.
	1-way metallic		
	Mounting frame plastic PBT black Lid: plastic, ABS gray	cURus Closure: 3 mm double bit with attachable rotation knob	4000-68513-0000001
	Mounting frame plastic PBT black Lid: plastic, ABS gray	Closure: Daimler	4000-68513-0000003
	2-way metallic		
	Mounting frame plastic PBT black Lid: plastic, ABS gray	cURus Closure: 3 mm double bit with attachable rotation knob	4000-68523-0000001
	Mounting frame plastic PBT black Lid: plastic, ABS gray	Closure: Daimler	4000-68523-0000003



FRONT PANEL INTERFACES

Power outlets			Art-No.
	<p>Germany (VDE) white Screw terminals: max. 6 mm² Operating voltage: max. 250 V AC Operating current: max. 16 A</p>	LED (yellow)	4000-68000-0010000
	<p>USA (NEMA 5-15) Plug-solder connection: 4.8 × 0.8 mm Operating voltage: max. 125 V AC Operating current: max. 15 A</p>	cURus	4000-68000-0030000
	<p>England (BS) Screw terminals: max. 4 mm² Operating voltage: max. 250 V AC Operating current: max. 13 A</p>		4000-68000-0060000
	<p>EURO/USA Screw terminals: max. 2.5 mm² (AWG 14) Operating voltage: max. 250 V AC (EU); max. 125 V AC (USA) Operating current: max. 16 A (EU); max. 15 A (USA)</p>		4000-68000-0100000
	<p>Australia Screw terminals: max. 2.5 mm² (AWG 14) Operating voltage: max. 250 V AC Operating current: max. 10 A</p>		4000-68000-0090000
	<p>India (IS 1293) Screw terminals: max. 4 mm² Operating voltage: max. 240 V AC Operating current: max. 6 A</p>		4000-68000-3210000
	<p>China (CCC) Screw terminals: max. 4 mm² Operating voltage: max. 250 V AC Operating current: max. 10 A</p>		4000-68000-3250000

FRONT PANEL INTERFACES

Communication inserts			Art-No.
	<p>SUB-D15 HD; RJ45; USB; USB (formA) 1 × SUB-D15 HD (female/male) VGA 1 × RJ45, 8-pole metal, CAT5e (female/female) 2 × USB (female/female) form A</p>	<p>cURus shielded</p>	<p>4000-68000-1040000</p>
	<p>RJ45; USB (form A); DVI 1 × RJ45, 8-pole metal, CAT5e (female/female) 1 × USB (female/female) form A 1 × DVI (female/female)</p>		<p>4000-68000-0820000</p>
	<p>RJ45; RJ45; USB; USB (form A) 2 × RJ45, 8-pole metal, CAT5e (female/female) 2 × USB (female/female/0.7 m cable) form A</p>	<p>shielded</p>	<p>4000-68000-0990000</p>
	<p>SUB-D9; RJ45; USB (form A) 1 × SUB-D9 (female/female) 1 × RJ45, 8-pole metal, CAT5e (female/female) 1 × USB (female/female/0.7 m cable) form A</p>	<p>shielded</p>	<p>4000-68000-1420000</p>
	<p>USA (NEMA 5-15); RJ45; SUB-D9 1 × NEMA 1-15 (plug-solder connection) 1 × RJ45, 8-pole metal, CAT5e (female/female) 1 × SUB-D9 (female/female)</p>	<p>cURus</p>	<p>4000-68000-4010000</p>
	<p>USA (NEMA 5-15); RJ45; SUB-D9 HD; fuse 1 × NEMA 5-15 (screw terminals) 1 × RJ45, 8-pole metal, CAT5e (female/female) 1 × SUB-D9 (male/female) 1 × fuse (3 A)</p>	<p>cURus with touch protection</p>	<p>4000-68000-4230000</p>

FRONT PANEL INTERFACES

Pass-through			Art-No.
	Pass-through 1 × RJ45, 8-pole metal, CAT5e (female/female)	cULus	4000-73000-0010000
	Pass-through 1 × USB 3.0 (female/male) form A, 0.6 m cable 1 × USB 3.0 (female/male) form A, 1.0 m cable 1 × USB 3.0 (female/male) form A, 1.5 m cable 1 × USB 3.0 (female/male) form A, 2.0 m cable	cULus cULus cULus cULus	4000-73000-0150000 4000-73000-0160000 4000-73000-0170000 4000-73000-0180000

CONTROL CABINET INTERFACES / CABLE ENTRY SYSTEMS

- Durable connections
- Modular system
- High protection degree

MODLINK MPV CABLE ENTRY SYSTEM

The article numbers help you figure out whether you are ordering inserts, individual frames or sets.
A set has one part number for up to three components.

THE MODLINK MPV SET

The set article number is made up of **A, B** and **C**.

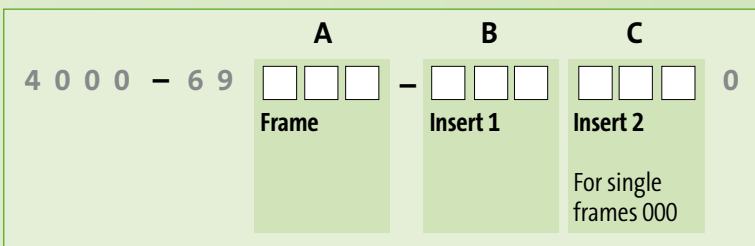

First select your components:

- Block A:** Frame (z. B. 4000-69**122**-000 0000 for double frame)
Block B: Insert 1 (z. B. 4000-69000-**100** 0000 for M12/Sub-D)
Block C: Insert 2 (z. B. 4000-69000-**200** 0000 for 7/8"/spring clamp terminal)

The article number for this example set will be:

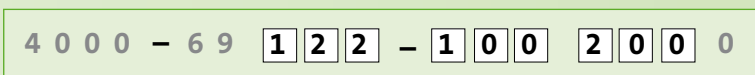

Control Cabinet Interfaces



Modlink MPV – modular

- Frames
- Inserts
- Accessories

Page 2.2.1



Control cabinet interface – predefined

- Push-Pull

[see onlineshop.murrelektronik.com/en](http://see.onlineshop.murrelektronik.com/en)

Cable Entry Systems



Cable entry system – modular

- Cable entry plate
- Inserts

[see onlineshop.murrelektronik.com/en](http://see.onlineshop.murrelektronik.com/en)



Cable entry system – predefined

- Rectangular
- Round

[see onlineshop.murrelektronik.com/en](http://see.onlineshop.murrelektronik.com/en)

MPV Frame			Art-No.
	<p>Single (30°-angle) for standard cut-out Size 6 (35 × 52 mm) IP65</p>	cURus	4000-69212-000000
	<p>Double (30°-angle) for standard cut-out Size 24 (35 × 112 mm) IP65</p>	cURus	4000-69222-000000
MPV Inserts			Art-No.
	<p>M12 M12 (male/female) 5-pole IP65 M12 (male/female) 5-pole, B-coded IP65 M12 (male/female) 6-pole, Cube67 IP65</p>	cURus	4000-69000-1040000 4000-69000-1060000 4000-69000-1080000
	<p>M12; terminators M12 (male) 5-pole, A-coded Spring clamp terminal connection IP65</p>		4000-69000-1050000
	<p>M12; RJ45 M12 (female) 4-pole, D-coded RJ45 (8/8-pole) metal, CAT6 IP65</p>		4000-69000-1100000
	<p>7/8"; Spring clamp terminal 7/8" (female) Spring clamp terminal connection IP65</p>	cURus	4000-69000-2000000
	<p>7/8"; Spring clamp terminal 7/8" (male) Spring clamp terminal connection</p>		4000-69000-2040000

LIGHTING ELEMENTS HIGHLY FLEXIBLE

- Modular design
- Extremely bright
- Energy saving LED technology

MODLIGHT AND COMLIGHT PROVIDE EXCELLENT LIGHTING

Energy saving and durable LED technology are only some of the advantages of Murrelektronik's lighting systems. The Modlight50 and Modlight70 signal towers can be combined in various colors. The components can be conveniently connected via notched contacts. The Modlight XTREME 440 machine lighting with IP69K protection provides excellent light that's equivalent to daylight, even in rugged industrial environments.

Signal Towers



Modlight30/50/70
• 30 mm/50 mm/70 mm

Page 2.3.3



Comlight57
• 57 mm diameter
• Single element

Page 2.3.4

Machine Lighting











Modlight Xtreme 440
• Machine lighting
• IP69K

Page 2.3.5

Connection modules			Art-No.
	Modlight50		
	Basic (170 mm)	Spring clamp terminals cULus	4000-75050-1100002
	Basic + buzzer + flash (170 mm)	Spring clamp terminals cULus	4000-75050-1100003
	Modlight70		
	Basic (77.5 mm)	Spring clamp terminals cULus	4000-75070-1100012
	Modlight70		
	Basic (170 mm)	Spring clamp terminals cULus	4000-75070-1100002
	Basic + buzzer + flash (170 mm)	Spring clamp terminals cULus	4000-75070-1100003
	Modlight70		
	Basic (170 mm)	M12 (8-pole), down	4000-75070-1300002
	Basic + buzzer + flash (170 mm)	M12 (8-pole), down	4000-75070-1300003
	Modlight70		
	Basic (170 mm)	M12 (8-pole), sideways	4000-75070-1400002
	Basic + buzzer + flash (170 mm)	M12 (8-pole), sideways	4000-75070-1400003
	Modlight70 with magnet base		
	Basic (170 mm)	M12 (8-pole), sideways	4000-75070-1500002
	Basic + buzzer + flash (170 mm) with magnet base	M12 (8-pole), sideways	4000-75070-1500003

LIGHTING ELEMENTS

Connection modules			Art-No.
	Modlight70 (AS-Interface)		
	Basic (170 mm) for 4 signals	M12 (4-pole), bottom AS-Interface-supply	4000-75070-1300004
	Basic + buzzer (170 mm) for 4 signals	M12 (4-pole), bottom AS-Interface-supply	4000-75070-1300005
	Basic (170 mm) for 4 signals	M12 (4-pole), bottom External supply	4000-75070-1300006
	Basic + buzzer (170 mm) for 4 signals	M12 (4-pole), bottom External supply	4000-75070-1300007
	Basic (170 mm) for 5 signals	M12 (4-pole), bottom External supply 2 × AB-Slave	4000-75070-1300008
	Basic + buzzer (170 mm) for 7 signals	M12 (4-pole), bottom External supply 2 × AB-Slave	4000-75070-1300009
	Modlight70 (AS-Interface)		
	Basic (170 mm) for 4 signals	M12 (4-pole), sideways AS-Interface-supply	4000-75070-1400004
	Basic + buzzer (170 mm) for 4 signals	M12 (4-pole), sideways AS-Interface-supply	4000-75070-1400005
	Basic (170 mm) for 4 signals	M12 (4-pole), sideways External supply	4000-75070-1400006
	Basic + buzzer (170 mm) for 4 signals	M12 (4-pole), sideways External supply	4000-75070-1400007
	Basic (170 mm) for 5 signals	M12 (4-pole), sideways External supply 2 × AB-Slave	4000-75070-1400008
	Basic + buzzer (170 mm) for 7 signals	M12 (4-pole), sideways External supply 2 × AB-Slave	4000-75070-1400009
	Modlight70 with magnet base (AS-Interface)		
	Basic (170 mm) for 4 signals for LED modules	M12 (4-pole), sideways External supply	4000-75070-1500004
	Basic (170 mm) for 4 signals for LED modules and LED flash modules	M12 (4-pole), sideways External supply	4000-75070-1500006
	Basic + buzzer (170 mm) for 4 signals	M12 (4-pole), sideways External supply	4000-75070-1500007
LED modules			Art-No.
	Modlight		
	LED module Modlight50	cULus	4000-75050-1011000
	LED module Modlight70	cULus	4000-75070-1011000
	LED flash module Modlight70	cULus	4000-75070-1021000
	Modlight		
	LED module Modlight50	cULus	4000-75050-1012000
	LED module Modlight70	cULus	4000-75070-1012000
	LED flash module Modlight70	cULus	4000-75070-1022000

LED modules			Art-No.
	Modlight		
	LED module Modlight50	cULus	4000-75050-1013000
	LED module Modlight70	cULus	4000-75070-1013000
	Modlight		
	LED module Modlight50	cULus	4000-75050-1014000
	LED module Modlight70	cULus	4000-75070-1014000
	Modlight		
	LED module Modlight50	cULus	4000-75050-1015000
	LED module Modlight70	cULus	4000-75070-1015000
	LED flash module Modlight70	cULus	4000-75070-1025000
Set			Art-No.
	Modlight30 (green/yellow/red)		
	Connection module + LED modules		4000-75324-5310000
	Connection cable L = 3 m		
	Modlight50 (green/yellow/red)		
	Basic + LED modules		4000-75501-5310000
	Basic, buzzer, flash + LED modules		4000-75502-5310000
	Modlight70 (green/yellow/red)		
	Basic + LED modules + M12 (down)		4000-75704-5310000
	Basic, buzzer, flash + LED modules + M12 (down)		4000-75705-5310000
	Basic + LED modules + M12 (side)		4000-75712-5310000
	Basic, buzzer, flash + LED modules + M12 (side)		4000-75713-5310000
	Modlight70 (green/yellow/red/transparent)		
	Basic, buzzer, flash + LED modules + M12 (side) + LED flash (transparent)		4000-75713-1358000

LIGHTING ELEMENTS





Compact status light			Art-No.
	Comlight57	red	4000-75057-1111000
	Comlight57	yellow	4000-75057-1112000
	Comlight57	green	4000-75057-1113000
	Comlight57	blue	4000-75057-1114000
	Comlight57	clear	4000-75057-1115000
	Comlight57 Bride mâle M12 4-pole	red	4000-75057-1311000
	Comlight57 Bride mâle M12 4-pole	yellow	4000-75057-1312000

Compact status light			Art-No.
	Comlight57 Bride mâle M12 4-pole	green	4000-75057-1313000
	Comlight57 Bride mâle M12 4-pole	blue	4000-75057-1314000
	Comlight57 Bride mâle M12 4-pole	clear	4000-75057-1315000
Modlight XTREME			Art-No.
	LED machine lamp 24 V DC/1.2 A Stainless Steel	IP69K	4000-75827-1315000
	Xtreme joint coupling		4000-75800-0000900

LIGHTING ELEMENTS

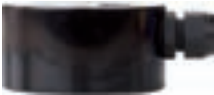
Accessories Modlight30			Art-No.
	Adapter for wall assembly		
			4000-75030-0000903
Accessories Modlight70/50			Art-No.
	Top adapter for tube mounting		
		for Modlight70	4000-75070-0000900
		for Modlight50	4000-75050-0000900
	Bottom adapter for tube mounting		
		for Modlight70/50	4000-75070-0000901
	Adapter for tube/wall mounting	for Modlight70/50	4000-75070-0000902
	Adapter for wall assembly	for Modlight70	4000-75070-0000903
	Adapter for wall assembly Cable outlet (on the bottom)	for Modlight70	4000-75070-0000904
	Aluminum tube		
	300 mm	for Modlight70/50	4000-75070-0000913
	800 mm	for Modlight70/50	4000-75070-0000918

LIGHTING ELEMENTS

Accessories Modlight70/50			Art-No.
	Magnet base with M16 × 1.5 gland	Sideways cable entry point for Modlight70/50	4000-75070-0000920
	Magnet base with M12 flange plug connector (8-pole)	Sideways connection for Modlight70/50	4000-75070-0000921
	Mounting adapter for strain relief	bottom or side exit	4000-75070-0000922
	transparent transparent	for Modlight70 for Modlight50	4000-75070-0000923 4000-75050-0000923



M8 ROUND PLUG CONNECTORS

SMALL, LIGHT, MEETS YOUR NEEDS

- Extensive selection
- Tested technology
- Modern design

M8 REDESIGN – MORE MODELS, & NEW DESIGN

M8's redesign introduces new innovations. We completely redesigned all Murrelektronik's molded M8 connectors. They now have a new look and have been upgraded. We also significantly expanded our range of shielded M8 connectors.

Features:

- Durable PUR molding
- Gold plated contacts
- Small dimensions and improved feel
- Corrugated tubing connection
- Hex screw with thread (SW9)

Huge Variety:

- Male/female, straight/90°, 3-pole/4-pole
- Shielded and unshielded connectors
- 3 standard colors, 4 standard cable types
- Cables, open ended wires, T-couplers, adapters, models with LED

With Open Ended Wires



M8 male
• Straight
• 90°

Page 3.1.1

** see onlineshop.murrelektronik.com/en*

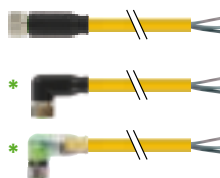

M8 female
• Straight
• 90°
• 90° with LED

Page 3.1.2

** see onlineshop.murrelektronik.com/en*



M8 male (shielded)
• Straight
• 90°

Page 3.1.3

** see onlineshop.murrelektronik.com/en*







M8 female (shielded)
• Straight
• 90°

Page 3.1.4

** see onlineshop.murrelektronik.com/en*

Connection Cables

		<p>M8 male</p> <ul style="list-style-type: none"> • Straight 	<p>M8 female</p> <ul style="list-style-type: none"> • Straight • 90° • 90° with LED <p><i>Page 3.1.5</i> <i>* see onlineshop.murrelektronik.com/en</i></p>
		<p>M8 male</p> <ul style="list-style-type: none"> • Straight • 90° 	<p>M12 female</p> <ul style="list-style-type: none"> • Straight • 90° • 90° with LED <p><i>Page 3.1.6</i> <i>* see onlineshop.murrelektronik.com/en</i></p>

Field-Wireable

	<p>Insulation Displacement Technology 0.25...0.5 mm²</p>	<p>M8 male/female</p> <ul style="list-style-type: none"> • Straight 	<p><i>Page 3.1.7</i></p>
	<p>Insulation Displacement Technology 0.14...0.34 mm²</p>	<p>M8 male/female</p> <ul style="list-style-type: none"> • Straight 	<p><i>Page 3.1.8</i></p>
	<p>Solder pins</p>	<p>M8 male/female</p> <ul style="list-style-type: none"> • Straight • 90° 	<p><i>see onlineshop.murrelektronik.com/en</i></p>
	<p>Screw Terminals</p>	<p>M8 male/female</p> <ul style="list-style-type: none"> • Straight 	<p><i>Page 3.1.9</i></p>
	<p>Screw terminals (shielded)</p>	<p>M8 male/female</p> <ul style="list-style-type: none"> • Straight 	<p><i>see onlineshop.murrelektronik.com/en</i></p>

NOTES

A large grid of small dots for taking notes, consisting of 30 columns and 40 rows of dots.

M8 ROUND PLUG CONNECTORS

With open ended wires

Male

straight



Approvals:   

* only for products with UL/CSA approved cable

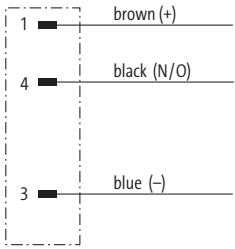
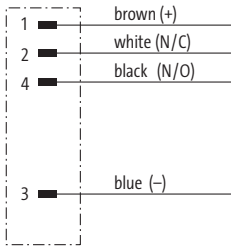
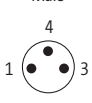
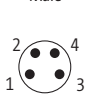
1 Form	08001	me	08011	me		
Type	3-pole		4-pole			
Circuit diagram						
Contact layout						
2 Cable Type	Jacket Color		Jacket Color			
Wire diameter 0.25 mm ²	yellow	gray	black	yellow	gray	black
PVC (UL/CSA)	010	210	610	011	211	611
PUR/PVC (UL/CSA)	020	220	620	021	221	621
PUR (UL/CSA)	030	230	630	031	231	631
PUR (UL/CSA), welding spark res.	050	250	650	051	251	651
3 Cable Length						
1.5 m	0150					
3.0 m	0300					
5.0 m	0500					
7.5 m	0750					
10.0 m	1000					
Technical Data						
Operating voltage	max. 60 V AC/DC			max. 30 V AC/DC		
Protection	IP67 inserted and tightened (EN 60529)					
Temperature range	-25...+85 °C, depending on cable quality					
Article No.						
The composition of your article number is explained on page 3.1.i	<div style="display: flex; justify-content: space-around; align-items: center;"> 7 0 0 0 - - </div>					
	1 Form		2 Cable Type		3 Cable Length	
Notes	Other versions on request. Differing cable lengths up to 2 m can be ordered in 0.2 m steps, from 2 m on in 0.5 m steps.					

M8 ROUND PLUG CONNECTORS

With open ended wires

Female
straight



Approvals:   

* only for products with UL/CSA approved cable

M8 Round Plug Connectors

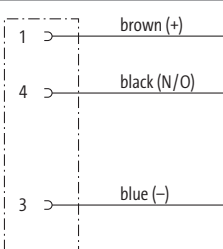
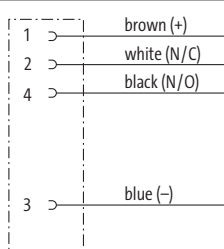
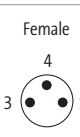
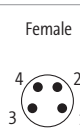
1 Form	08041	meX	08061	meX					
Type	3-pole		4-pole						
Circuit diagram									
Contact layout									
2 Cable Type	Jacket Color			Jacket Color					
Wire diameter 0.25 mm ²	yellow	gray	black	yellow	gray	black			
PVC (UL/CSA)	010	210	610	011	211	611			
PUR/PVC (UL/CSA)	020	220	620	021	221	621			
PUR (UL/CSA)	030	230	630	031	231	631			
PUR (UL/CSA), welding spark res.	050	250	650	051	251	651			
3 Cable Length									
1.5 m	0150								
3.0 m	0300								
5.0 m	0500								
7.5 m	0750								
10.0 m	1000								
Technical Data									
Operating voltage	max. 60 V AC/DC			max. 30 V AC/DC					
Protection	IP67 inserted and tightened (EN 60529)								
Temperature range	-25...+85 °C, depending on cable quality								
Article No.									
The composition of your article number is explained on page 3.1.i	<div style="display: flex; justify-content: space-around; align-items: center;"> 7 0 0 0 - - </div>								
	1	Form		2	Cable Type		3	Cable Length	
Notes	Other versions on request. Differing cable lengths up to 2 m can be ordered in 0.2 m steps, from 2 m on in 0.5 m steps.								

M8 ROUND PLUG CONNECTORS

With open ended wires

– shielded



Male

straight

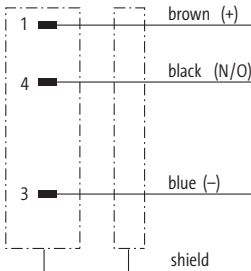
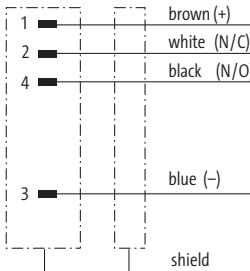

Approvals:  

M8 Round Plug Connectors

1 Form		08701	08711
Type		3-pole	4-pole
Circuit diagram			
Contact layout		<p>Male</p> 	<p>Male</p> 
2 Cable Type		Jacket Color	Jacket Color
Wire diameter 0.34 mm ²		gray	black
PVC (UL/CSA)		200	600
PUR (UL/CSA)		240	640
3 Cable Length			
1.5 m		0150	
3.0 m		0300	
5.0 m		0500	
7.5 m		0750	
10.0 m		1000	
Technical Data			
Operating voltage		max. 60 V AC/DC	max. 30 V AC/DC
Protection		IP67 inserted and tightened (EN 60529)	
Temperature range		-25...+85 °C, depending on cable quality	
Article No.			
The composition of your article number is explained on page 3.1.i		7 0 0 0	- - - - -
		1 Form	2 Cable Type 3 Cable Length
Notes		Other versions on request. Differing cable lengths up to 2 m can be ordered in 0.2 m steps, from 2 m on in 0.5 m steps.	

M8 ROUND PLUG CONNECTORS

With open ended wires

– shielded

Female
straight



Approvals:

M8 Round Plug Connectors

1 Form		08741	08761	
Type		3-pole	4-pole	
Circuit diagram				
Contact layout		<p>Female</p>	<p>Female</p>	
2 Cable Type	Jacket Color	Jacket Color		
	Wire diameter 0.34 mm ²	gray	black	
	PVC (UL/CSA)	200	600	
PUR (UL/CSA)	240	640	241	641
3 Cable Length	1.5 m	0150		
	3.0 m	0300		
	5.0 m	0500		
	7.5 m	0750		
	10.0 m	1000		
Technical Data				
Operating voltage	max. 60 V AC/DC		max. 30 V AC/DC	
Protection	IP67 inserted and tightened (EN 60529)			
Temperature range	-25...+85 °C, depending on cable quality			
Article No.				
The composition of your article number is explained on page 3.1.i		<div style="display: flex; justify-content: space-around; align-items: center;"> 7 0 0 0 - - </div>		
		1 Form	2 Cable Type	
		3 Cable Length		
Notes		Other versions on request. Differing cable lengths up to 2 m can be ordered in 0.2 m steps, from 2 m on in 0.5 m steps.		

M8 ROUND PLUG CONNECTORS

Connection cables

– M8 - M8

Male

straight

Female

straight



Approvals:   

* only for products with UL/CSA approved cable

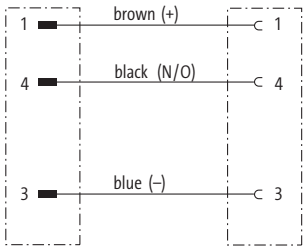
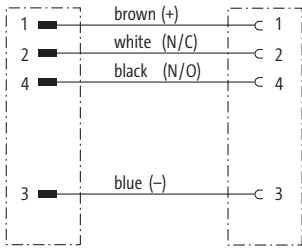
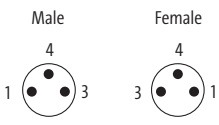
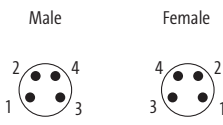
1 Form	88001	me	88011
Type	3-pole		4-pole
Circuit diagram			
Contact layout			
2 Cable Type	Jacket Color		Jacket Color
Wire diameter 0.25 mm ²	yellow	gray	black
PVC (UL/CSA)	010	210	610
PUR/PVC (UL/CSA)	020	220	620
PUR (UL/CSA)	030	230	630
PUR (UL/CSA), welding spark res.	050	250	650
3 Cable Length			
0.3 m	0030		
0.6 m	0060		
1.0 m	0100		
1.5 m	0150		
2.0 m	0200		
Technical Data			
Operating voltage	max. 60 V AC/DC		max. 30 V AC/DC
Protection	IP67 inserted and tightened (EN 60529)		
Temperature range	-25...+85 °C, depending on cable quality		
Article No.			
The composition of your article number is explained on page 3.1.i	<div style="display: flex; justify-content: space-around; align-items: center;"> 7 0 0 0 - - </div>		
	1 Form	2 Cable Type	3 Cable Length
Notes	Other versions on request. Differing cable lengths up to 2 m can be ordered in 0.2 m steps, from 2 m on in 0.5 m steps.		

M8 ROUND PLUG CONNECTORS

Connection cables

– M8 - M12



* only for products with UL/CSA approved cable

Male

straight

Female

straight



1 Form	88241	meX	88251	meX		
Type	3-pole		4-pole			
Circuit diagram						
Contact layout						
2 Cable Type	Jacket Color			Jacket Color		
Wire diameter 0.25 mm ²	yellow	gray	black	yellow	gray	black
PVC (UL/CSA)	010	210	610	011	211	611
PUR/PVC (UL/CSA)	020	220	620	021	221	621
PUR (UL/CSA)	030	230	630	031	231	631
PUR (UL/CSA), welding spark res.	050	250	650	051	251	651
3 Cable Length						
0.3 m	0030					
0.6 m	0060					
1.0 m	0100					
1.5 m	0150					
2.0 m	0200					
Technical Data						
Operating voltage	max. 60 V AC/DC			max. 30 V AC/DC		
Protection	IP67 inserted and tightened (EN 60529)					
Temperature range	-25...+85 °C, depending on cable quality					
Article No.						
The composition of your article number is explained on page 3.1.i	<div style="display: flex; justify-content: space-around; align-items: center;"> 7 0 0 0 - - </div>					
	1	Form	2	Cable Type	3	Cable Length
Notes	Other versions on request. Differing cable lengths up to 2 m can be ordered in 0.2 m steps, from 2 m on in 0.5 m steps.					

M8 ROUND PLUG CONNECTORS

Field-wireable

– IDC terminals

Male

straight



Female

straight



Approvals:

M8 Round Plug Connectors

1 Form	08321 me✘	08341 me✘	08361 me✘	08381 me✘
Type	3-pole	4-pole	3-pole	4-pole
Circuit diagram				
Connection cross section	0.25...0.5 mm ²			
Contact layout				
Technical Data				
Operating voltage	max. 32 V AC/DC			
Operating current per contact	max. 4 A			
Connection cross section	0.25...0.5 mm ² (conductor diameter min. 0.1 mm)			
Sealing range (cable diameter)	4...5.1 mm			
Wire isolation	PVC, PP, TPE			
Outer wire diameter	1.2...1.6 mm			
Protection	IP67 inserted and tightened (EN 60529)			
Temperature range	-25...+85 °C			
Article No.				
The composition of your article number is explained on page 3.1.i	<u>7</u> <u>0</u> <u>0</u> <u>0</u>	-	<u>0</u> <u>0</u> <u>0</u>	<u>0</u> <u>0</u> <u>0</u> <u>0</u>
	1 Form			
Notes	Other versions on request.			

M8 ROUND PLUG CONNECTORS

Field-wireable
– IDC terminals

Male
straight

Female
straight



Approvals:

M8 Round Plug Connectors

1 Form	08331 me*	08351 me*	08371 me*	08391 me*
Type	3-pole	4-pole	3-pole	4-pole
Circuit diagram				
Connection cross section	0.14...0.34 mm ²			
Contact layout	<p>Male</p>	<p>Male</p>	<p>Female</p>	<p>Female</p>
Technical Data				
Operating voltage	max. 32 V AC/DC			
Operating current per contact	max. 4 A			
Connection cross section	0.14...0.34 mm ² (conductor diameter min. 0.1 mm)			
Sealing range (cable diameter)	2.5...5.1 mm (gasket included)			
Wire isolation	PVC, PP, TPE			
Outer wire diameter	1.0...1.6 mm			
Protection	IP67 inserted and tightened (EN 60529)			
Temperature range	-25...+85 °C			
Article No.				
The composition of your article number is explained on page 3.1.i	<u>7</u> <u>0</u> <u>0</u> <u>0</u>	-	-	<u>0</u> <u>0</u> <u>0</u> <u>0</u>
	1 Form			
Notes	Other versions on request.			

M8 ROUND PLUG CONNECTORS

Field-wireable

– Screw terminals

Male

straight



Female

straight



Approvals:

M8 Round Plug Connectors

1 Form	08601	08611	08621	08631
Type	3-pole	4-pole	3-pole	4-pole
Circuit diagram				
Connection cross section	0.14...0.5 mm ²			
Contact layout	<p>Male</p>	<p>Male</p>	<p>Female</p>	<p>Female</p>
Technical Data				
Operating voltage	max. 60 V AC/DC	max. 30 V AC/DC	max. 60 V AC/DC	max. 30 V AC/DC
Operating current per contact	max. 4 A			
Connection cross section	0.14...0.5 mm ²			
Sealing range (cable diameter)	2.5...5.0 mm			
Protection	IP67 inserted and tightened (EN 60529)			
Temperature range	-25...+85 °C			
Article No.				
The composition of your article number is explained on page 3.1.i	<u>7</u> <u>0</u> <u>0</u> <u>0</u>	-	<u>0</u> <u>0</u> <u>0</u>	<u>0</u> <u>0</u> <u>0</u> <u>0</u>
	1 Form			
Notes	Other versions on request.			



M12 ROUND PLUG CONNECTORS COMPREHENSIVE AND VERSATILE

- The right model for any application
- Shock and vibration resistant with integrated fastening
- Reliable – 100% tested

M12 CONNECTORS – DESIGNED FOR MANY DIFFERENT CUSTOMER APPLICATIONS

Murrelektronik offers one of the most comprehensive M12 connector ranges on the market.

Reliable, quick and easy assembly, a clear LED indicator: these are only a few of the features that make this product range one of the best.









Features

- Combined hex screw with thread for secure connections
- Highly resistant, halogen-free PUR molding guarantees IP67/68 seal
- Wide range of cable material and color – always the right choice for your application



With Open Ended Wires

 <p>M12 male</p> <ul style="list-style-type: none"> • Straight • 90° <p><i>Page 3.2.1</i> <i>* see onlineshop.murrelektronik.com/en</i></p>	 <p>M12 female</p> <ul style="list-style-type: none"> • Straight • 90° <p><i>Page 3.2.4</i></p>
 <p>M12 female with LED</p> <ul style="list-style-type: none"> • Straight • 90° <p><i>Page 3.2.8</i></p>	 <p>M12 male (shielded)</p> <ul style="list-style-type: none"> • Straight • 90° <p><i>Page 3.2.9</i> <i>* see onlineshop.murrelektronik.com/en</i></p>
 <p>M12 female (shielded)</p> <ul style="list-style-type: none"> • Straight • 90° <p><i>Page 3.2.11</i> <i>* see onlineshop.murrelektronik.com/en</i></p>	

Connection Cables

		<p>M12 male</p> <ul style="list-style-type: none"> • Straight • 90° 	<p>M12 female</p> <ul style="list-style-type: none"> • Straight • 90° • 90° with LED <p><i>Page 3.2.13</i> <i>* see onlineshop.murrelektronik.com/en</i></p>
		<p>M12 Y connector male</p> <ul style="list-style-type: none"> • Straight 	<p>M12 female</p> <ul style="list-style-type: none"> • Straight • 90° • 90° with LED <p><i>Page 3.2.15</i> <i>* see onlineshop.murrelektronik.com/en</i></p>
		<p>M12 male (shielded)</p> <ul style="list-style-type: none"> • Straight acc. to DESINA® 	<p>M12 female (shielded)</p> <ul style="list-style-type: none"> • Straight acc. to DESINA® <p><i>Page 3.2.16</i></p>
		<p>M12 male</p> <ul style="list-style-type: none"> • Straight 	<p>M8 female</p> <ul style="list-style-type: none"> • Straight • 90° • 90° with LED <p><i>Page 3.2.17</i> <i>* see onlineshop.murrelektronik.com/en</i></p>
		<p>M12 Y connector male</p> <ul style="list-style-type: none"> • Straight 	<p>M8 female</p> <ul style="list-style-type: none"> • Straight • 90° • 90° with LED <p><i>* see onlineshop.murrelektronik.com/en</i></p>

Field-Wireable

	<p>Insulation Displacement Technology</p>	<p>M12 male/female</p> <ul style="list-style-type: none"> • Straight • 90° <p>M12 female</p> <ul style="list-style-type: none"> • 90° with LED 	<p><i>Page 3.2.18</i></p>
	<p>Screw Terminals</p>	<p>M12 male/female</p> <ul style="list-style-type: none"> • Straight • 90° <p>M12 Y connector male</p> <ul style="list-style-type: none"> • Straight 	<p><i>Page 3.2.24</i></p>
	<p>Screw Terminals (shielded)</p>	<p>M12 male/female</p> <ul style="list-style-type: none"> • Straight • 90° 	<p><i>see onlineshop.murrelektronik.com/en</i></p>

NOTES

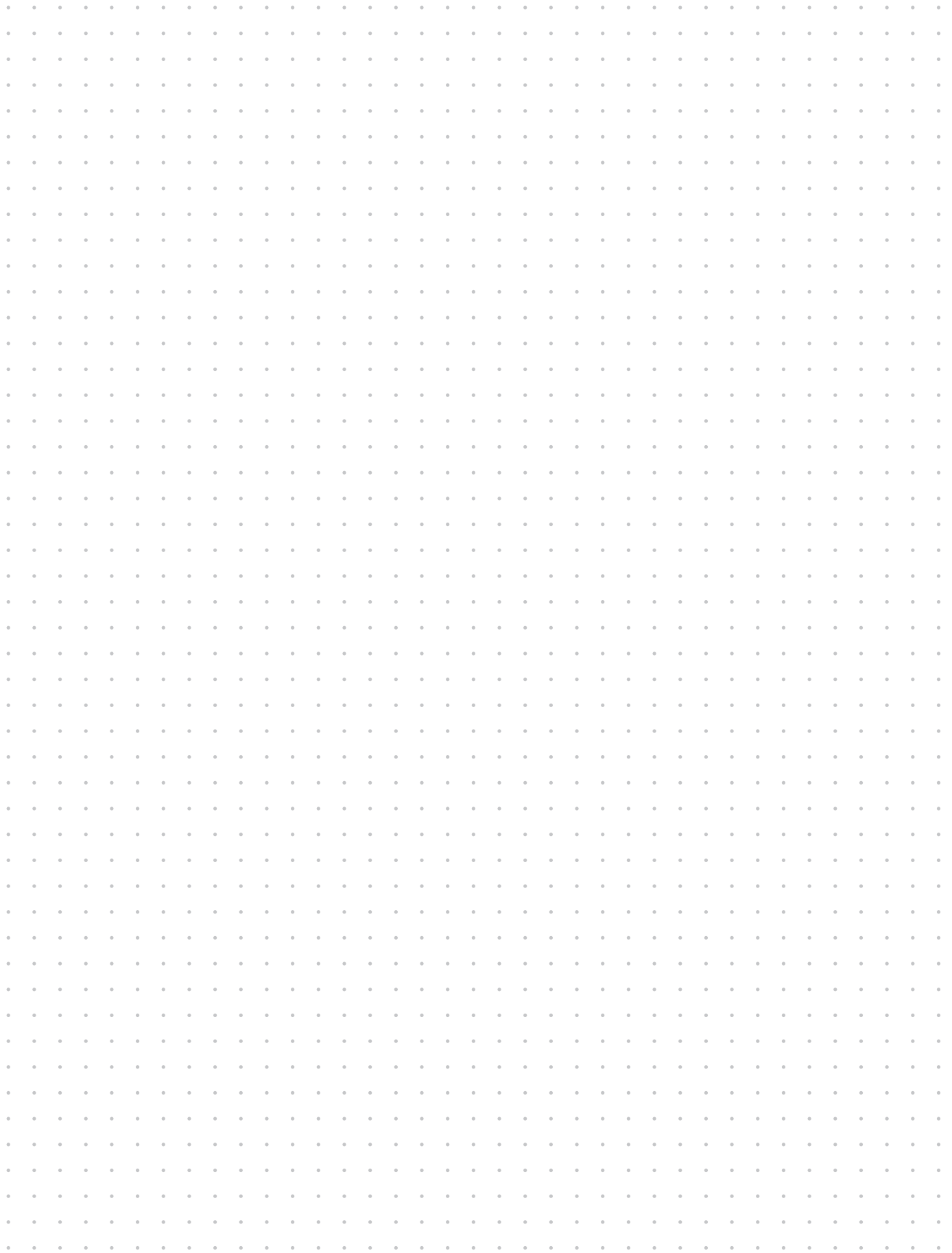

M12 ROUND PLUG CONNECTORS

With open ended wires

Male
straight



Approvals:

* only for products with UL/CSA approved cable

1 Form	12001 me	12021 me	12041 me						
Type	3-pole	4-pole	5-pole						
Circuit diagram			<p>(* for cable type 126 and 732)</p>						
Contact layout	<p>Male</p>	<p>Male</p>	<p>Male</p>						
2 Cable Type	Jacket Color								
Wire diameter 0.34 mm ²	yellow	gray	black	yellow	gray	black	yellow	gray	black
PVC (UL/CSA)	013	213	613	014	214	614	015	215	615
PUR/PVC (UL/CSA)	023	223	623	024	224	624	025	225	625
PUR (UL/CSA)	033	233	633	034	234	634	035 (126)	235	635 (732)
PUR (UL/CSA), welding spark res.	053	253	653	054	254	654	055	255	655
3 Cable Length									
1.5 m	0150								
3.0 m	0300								
5.0 m	0500								
7.5 m	0750								
10.0 m	1000								
Technical Data									
Operating voltage	max. 250 V AC/DC						max. 125 V AC/DC		
Protection	IP67 inserted and tightened (EN 60529)								
Temperature range	-25...+85 °C, depending on cable quality								
Article No.									
The composition of your article number is explained on page 3.1.i	<p>7 0 0 0 - - - - -</p> <p>7 0 0 5 M12 Lite (plastic hexagonal screw) on request</p>								
	1 Form			2 Cable Type			3 Cable Length		
Notes	Other versions on request. Differing cable lengths up to 2 m can be ordered in 0.2 m steps, from 2 m on in 0.5 m steps.								

M12 ROUND PLUG CONNECTORS

With open ended wires

Male

straight



Approvals:   

* only for products with UL/CSA approved cable

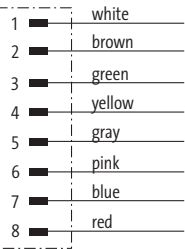
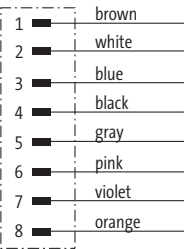
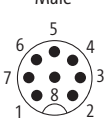
1 Form	170 01	170 01
	Type 8-pole	Type 8-pole
Circuit diagram		
Contact layout	<p>Male</p> 	
2 Cable Type	Jacket Color	Jacket Color
Wire diameter 0.25 mm ² PUR PUR (UL/CSA)	gray 292	gray 295
3 Cable Length		
1.5 m	0150	
3.0 m	0300	
5.0 m	0500	
7.5 m	0750	
10.0 m	1000	
Technical Data		
Operating voltage	max. 30 V AC/DC	
Protection	IP67 inserted and tightened (EN 60529)	
Temperature range	-25...+85 °C, depending on cable quality	
Article No.		
The composition of your article number is explained on page 3.1.i	<u>7</u> <u>0</u> <u>0</u> <u>0</u> - - - - - - - - - -	- - - - -
	<u>7</u> <u>0</u> <u>0</u> <u>5</u> M12 Lite (plastic hexagonal screw) on request	
	1 Form	2 Cable Type
		3 Cable Length
Notes	Other versions on request. Differing cable lengths up to 2 m can be ordered in 0.2 m steps, from 2 m on in 0.5 m steps.	

M12 Round Plug Connectors

M12 ROUND PLUG CONNECTORS

With open ended wires

Male

straight



Approvals:  

1 Form 19001

Type 12-pole

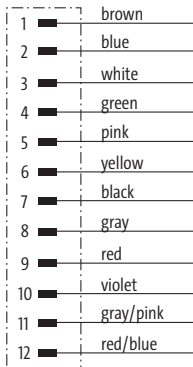
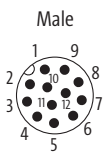
Circuit diagram	
Contact layout	<p>Male</p> 

2 Cable Type Jacket Color

Wire diameter 0.25 mm ² PUR (UL/CSA)	gray	black
	301	
Wire diameter 0.14 mm ² PVC		702
PUR (UL/CSA)		705

3 Cable Length

1.5 m	0150
3.0 m	0300
5.0 m	0500
7.5 m	0750
10.0 m	1000

Technical Data

Operating voltage	max. 30 V AC/DC
Protection	IP67 inserted and tightened (EN 60529)
Temperature range	-25...+85 °C, depending on cable quality

Article No.

The composition of your article number is explained on page 3.1.i	<u>7</u> <u>0</u> <u>0</u> <u>0</u> - <u>1</u> <u>9</u> <u>0</u> <u>0</u> <u>1</u> - _ _ _
	<u>7</u> <u>0</u> <u>0</u> <u>5</u> M12 Lite (plastic hexagonal screw) on request

1 Form **2** Cable Type **3** Cable Length

Notes

Other versions on request. Differing cable lengths up to 2 m can be ordered in 0.2 m steps, from 2 m on in 0.5 m steps.

M12 ROUND PLUG CONNECTORS

With open ended wires

Female
straight



Approvals: * only for products with UL/CSA approved cable

1 Form	12181 me \times	12221 me \times	12241 me \times						
Type	3-pole	4-pole	5-pole						
Circuit diagram			<p>(* for cable type 126 and 732)</p>						
Contact layout	<p>Female</p>	<p>Female</p>	<p>Female</p>						
2 Cable Type	Jacket Color								
Wire diameter 0.34 mm ²	yellow	gray	black	yellow	gray	black	yellow	gray	black
PVC (UL/CSA)	013	213	613	014	214	614	015	215	615
PUR/PVC (UL/CSA)	023	223	623	024	224	624	025	225	625
PUR (UL/CSA)	033	233	633	034	234	634	035 (126)	235	635 (732)
PUR (UL/CSA), welding spark res.	053	253	653	054	254	654	055	255	655
3 Cable Length									
1.5 m	0150								
3.0 m	0300								
5.0 m	0500								
7.5 m	0750								
10.0 m	1000								
Technical Data									
Operating voltage	max. 250 V AC/DC						max. 125 V AC/DC		
Protection	IP67 inserted and tightened (EN 60529)								
Temperature range	-25...+85 °C, depending on cable quality								
Article No.									
The composition of your article number is explained on page 3.1.i	7 0 0 0 - - - - - - - - - -								
	7 0 0 5 M12 Lite (plastic hexagonal screw) on request								
	1 Form			2 Cable Type			3 Cable Length		
Notes	Other versions on request. Differing cable lengths up to 2 m can be ordered in 0.2 m steps, from 2 m on in 0.5 m steps.								

M12 ROUND PLUG CONNECTORS

With open ended wires

Female

straight



Approvals:

* only for products with UL/CSA approved cable

1 Form		17041	17041
Type		8-pole	8-pole
Circuit diagram			
Contact layout		<p>Female</p>	
2 Cable Type		Jacket Color	Jacket Color
Wire diameter 0.25 mm ²		gray	gray
PUR		292	
PUR (UL/CSA)			295
3 Cable Length			
1.5 m		0150	
3.0 m		0300	
5.0 m		0500	
7.5 m		0750	
10.0 m		1000	
Technical Data			
Operating voltage		max. 30 V AC/DC	
Protection		IP67 inserted and tightened (EN 60529)	
Temperature range		-25...+85 °C, depending on cable quality	
Article No.			
The composition of your article number is explained on page 3.1.i		<u>7</u> <u>0</u> <u>0</u> <u>0</u> - - - - - - - - - -	- - - - -
		<u>7</u> <u>0</u> <u>0</u> <u>5</u> M12 Lite (plastic hexagonal screw) on request	
		1 Form	2 Cable Type
			3 Cable Length
Notes			
		Other versions on request. Differing cable lengths up to 2 m can be ordered in 0.2 m steps, from 2 m on in 0.5 m steps.	

M12 Round Plug Connectors

M12 ROUND PLUG CONNECTORS

With open ended wires

Female
straight



Approvals:   

1 Form **19041**

Type **12-pole**

Circuit diagram	
1	brown
2	blue
3	white
4	green
5	pink
6	yellow
7	black
8	gray
9	red
10	violet
11	gray/pink
12	red/blue

Contact layout Female

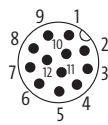

2 Cable Type **Jacket Color**

Wire diameter 0.25 mm ²	gray	black
PUR (UL/CSA)	301	
Wire diameter 0.14 mm ²		
PVC		702
PUR (UL/CSA)		705

3 Cable Length

1.5 m	0150
3.0 m	0300
5.0 m	0500
7.5 m	0750
10.0 m	1000

Technical Data

Operating voltage	max. 30 V AC/DC
Protection	IP67 inserted and tightened (EN 60529)
Temperature range	-25...+85 °C, depending on cable quality

Article No.

The composition of your article number is explained on page 3.1.i

7 0 0 0 - **1 9 0 4 1** - _ _ _ _

7 0 0 5 M12 Lite (plastic hexagonal screw) on request

1 Form **2** Cable Type **3** Cable Length

Notes

Other versions on request. Differing cable lengths up to 2 m can be ordered in 0.2 m steps, from 2 m on in 0.5 m steps.

M12 ROUND PLUG CONNECTORS

With open ended wires

– with LED



Female
straight



Female
90°

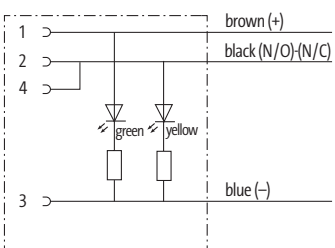

Approvals:    * only for products with UL/CSA approved cable

1 Form		12281	12401	meX			
Type		4-pole with 2 × LED (PNP) (NPN) on request	4-pole with 2 × LED (PNP) (NPN) on request				
Circuit diagram							
Contact layout	<p>Female</p> 						
2 Cable Type		Jacket Color			Jacket Color		
Wire diameter 0.34 mm ²		yellow	gray	black	yellow	gray	black
PVC (UL/CSA)		013	213	613	013	213	613
PUR/PVC (UL/CSA)		023	223	623	023	223	623
PUR (UL/CSA)		033	233	633	033	233	633
PUR (UL/CSA), welding spark res.		053	253	653	053	253	653
3 Cable Length							
1.5 m		0150					
3.0 m		0300					
5.0 m		0500					
7.5 m		0750					
10.0 m		1000					
Technical Data							
Operating voltage		24 V DC ±25 %					
Protection		IP67 inserted and tightened (EN 60529)					
Temperature range		-25...+85 °C, depending on cable quality					
Article No.							
The composition of your article number is explained on page 3.1.i		7 0 0 0			7 0 0 5		
		M12 Lite (plastic hexagonal screw) on request					
		1 Form		2 Cable Type		3 Cable Length	
Notes		Other versions on request. Differing cable lengths up to 2 m can be ordered in 0.2 m steps, from 2 m on in 0.5 m steps.					

M12 ROUND PLUG CONNECTORS

With open ended wires

– shielded

Male

straight



Approvals:  

1 Form	13061	13081	13101
Type	3-pole	4-pole	5-pole
Circuit diagram			
Contact layout	<p>Male</p>	<p>Male</p>	<p>Male</p>
2 Cable Type	Jacket Color	Jacket Color	Jacket Color
Wire diameter 0.34 mm ²	gray	gray	gray
PVC	317	330	348
PUR/PVC	318	331	349
3 Cable Length			
1.5 m	0150		
3.0 m	0300		
5.0 m	0500		
7.5 m	0750		
10.0 m	1000		
Technical Data			
Operating voltage	max. 60 V AC/DC		
Protection	IP67 inserted and tightened (EN 60529)		
Temperature range	-25...+85 °C, depending on cable quality		
Article No.			
The composition of your article number is explained on page 3.1.i	<p>7 0 0 0 - - - - -</p>		
	1 Form	2 Cable Type	3 Cable Length
Notes	Other versions on request. Differing cable lengths up to 2 m can be ordered in 0.2 m steps, from 2 m on in 0.5 m steps.		

M12 ROUND PLUG CONNECTORS

With open ended wires

– shielded

Male

straight



Approvals:   

* only for products with UL/CSA approved cable

M12 Round Plug Connectors

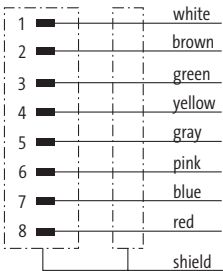
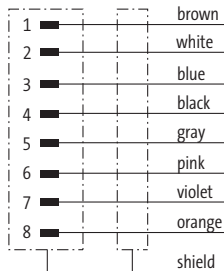
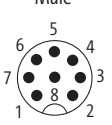
1 Form		17081	17081
Type		8-pole	8-pole
Circuit diagram			
Contact layout		<p>Male</p> 	
2 Cable Type		Jacket Color	Jacket Color
Wire diameter 0.25 mm ² PUR, suitable for C-tracks PUR (UL/CSA)		gray 291	gray 294
3 Cable Length			
1.5 m		0150	
3.0 m		0300	
5.0 m		0500	
7.5 m		0750	
10.0 m		1000	
Technical Data			
Operating voltage		max. 30 V AC/DC	
Protection		IP67 inserted and tightened (EN 60529)	
Temperature range		-25...+85 °C, depending on cable quality	
Article No.			
The composition of your article number is explained on page 3.1.i		7 0 0 0	- - - - -
		1 Form	2 Cable Type 3 Cable Length
Notes		Other versions on request. Differing cable lengths up to 2 m can be ordered in 0.2 m steps, from 2 m on in 0.5 m steps.	

M12 ROUND PLUG CONNECTORS

With open ended wires

– shielded

Female

straight



Approvals:  

1 Form	13181	13201	13221
Type	3-pole	4-pole	5-pole
Circuit diagram			
Contact layout	<p>Female</p>	<p>Female</p>	<p>Female</p>
2 Cable Type	Jacket Color	Jacket Color	Jacket Color
Wire diameter 0.34 mm ²	gray	gray	gray
PVC	317	330	348
PUR/PVC	318	331	349
3 Cable Length			
1.5 m	0150		
3.0 m	0300		
5.0 m	0500		
7.5 m	0750		
10.0 m	1000		
Technical Data			
Operating voltage	max. 60 V AC/DC		
Protection	IP67 inserted and tightened (EN 60529)		
Temperature range	-25...+85 °C, depending on cable quality		
Article No.			
The composition of your article number is explained on page 3.1.i	<p>7 0 0 0 - - - - -</p>		
	1 Form	2 Cable Type	3 Cable Length
Notes	Other versions on request. Differing cable lengths up to 2 m can be ordered in 0.2 m steps, from 2 m on in 0.5 m steps.		

M12 ROUND PLUG CONNECTORS

With open ended wires

– shielded

Female

straight



Approvals:  

1 Form

17121

17121

Type
Circuit diagram

8-pole

8-pole

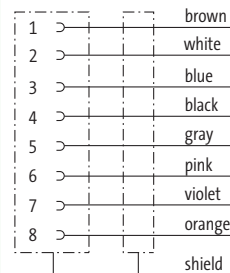
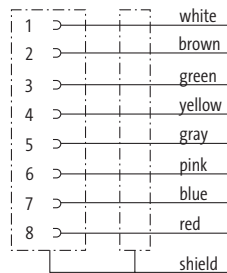

Contact layout

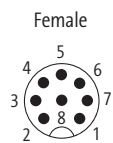

2 Cable Type

Jacket Color

Jacket Color

Wire diameter 0.25 mm²
PUR, suitable for Ctracks
PUR (UL/CSA)

gray
291

gray
294

3 Cable Length

1.5 m	0150
3.0 m	0300
5.0 m	0500
7.5 m	0750
10.0 m	1000

Technical Data

Operating voltage	max. 30 V AC/DC
Protection	IP67 inserted and tightened (EN 60529)
Temperature range	-25...+85 °C, depending on cable quality

Article No.

The composition of your article number is explained on page 3.1.i

7 0 0 0 - - - - -

1 Form

2 Cable Type

3 Cable Length

Notes

Other versions on request. Differing cable lengths up to 2 m can be ordered in 0.2 m steps, from 2 m on in 0.5 m steps.

M12 ROUND PLUG CONNECTORS

Connection cables

- M12 - M12

Male

straight

Female

straight



Approvals:

* only for products with UL/CSA approved cable

1 Form	40001 meX	40021 meX	40041 meX
Type	3-pole	4-pole	5-pole
Circuit diagram			<p>(* for cable type 126 and 732)</p>
Contact layout			
2 Cable Type	Jacket Color	Jacket Color	Jacket Color
Wire diameter 0.34 mm ²	yellow gray black	yellow gray black	yellow gray black
PVC (UL/CSA)	013 213 613	014 214 614	015 215 615
PUR/PVC (UL/CSA)	023 223 623	024 224 624	025 225 625
PUR (UL/CSA)	033 233 633	034 234 634	035 (126) 235 635 (732)
PUR (UL/CSA), welding spark res.	053 253 653	054 254 654	055 255 655
3 Cable Length			
0.3 m	0030		
0.6 m	0060		
1.0 m	0100		
1.5 m	0150		
2.0 m	0200		
0.7 m	0070		
4.0 m	0400		
Technical Data			
Operating voltage	max. 250 V AC/DC		max. 125 V AC/DC
Protection	IP67 inserted and tightened (EN 60529)		
Temperature range	-25...+85 °C, depending on cable quality		
Article No.			
The composition of your article number is explained on page 3.1.i	7 0 0 0 - - - - - 7 0 0 5 M12 Lite (plastic hexagonal screw) on request		
	1 Form	2 Cable Type	3 Cable Length
Notes	Other versions on request. Differing cable lengths up to 2 m can be ordered in 0.2 m steps, from 2 m on in 0.5 m steps.		

M12 ROUND PLUG CONNECTORS

Connection cables

– M12 - M12

Male

straight

Female

90° with LED



Approvals:   

* only for products with UL/CSA approved cable

1 Form	40321 me \times	40341 me \times	40361 me \times						
Type	3-pole with 2 \times LED (PNP) (NPN) on request	4-pole with 3 \times LED (PNP) (NPN) on request	5-pole with 3 \times LED (PNP) (NPN) on request						
Circuit diagram									
Contact layout									
2 Cable Type	Jacket Color								
Wire diameter 0.34 mm ²	yellow	gray	black	yellow	gray	black	yellow	gray	black
PVC (UL/CSA)	013	213	613	014	214	614	015	215	615
PUR/PVC (UL/CSA)	023	223	623	024	224	624	025	225	625
PUR (UL/CSA)	033	233	633	034	234	634	035 (126)	235	635 (732)
PUR (UL/CSA), welding spark res.	053	253	653	054	254	654	055	255	655
3 Cable Length									
0.3 m	0030								
0.6 m	0060								
1.0 m	0100								
1.5 m	0150								
2.0 m	0200								
Technical Data									
Operating voltage	24 V DC \pm 25 %								
Protection	IP67 inserted and tightened (EN 60529)								
Temperature range	-25...+85 °C, depending on cable quality								
Article No.									
The composition of your article number is explained on page 3.1.i	<div style="display: flex; justify-content: space-between; align-items: center;"> <u>7</u> <u>0</u> <u>0</u> <u>0</u> - _____ - _____ </div> <div style="display: flex; justify-content: space-between; align-items: center; margin-top: 5px;"> <u>7</u> <u>0</u> <u>0</u> <u>5</u> M12 Lite (plastic hexagonal screw) on request </div>								
	1 Form			2 Cable Type			3 Cable Length		
Notes	Other versions on request. Differing cable lengths up to 2 m can be ordered in 0.2 m steps, from 2 m on in 0.5 m steps.								

M12 ROUND PLUG CONNECTORS

Connection cables

– M12 - M12

Y connector

Male straight

Females

straight



Approvals:   

* only for products with UL/CSA approved cable

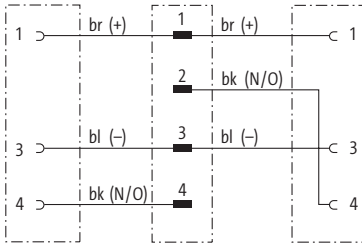
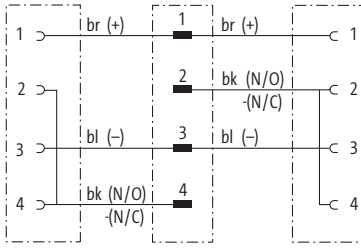
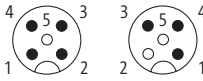
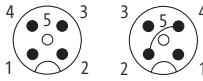
1 Form		40701			40721		
Type	4-pole				4-pole		
Circuit diagram							
Contact layout	<p>Y-Male Females</p> 				<p>Y-Male Females</p> 		
2 Cable Type		Jacket Color			Jacket Color		
Wire diameter 0.34 mm ²		yellow	gray	black	yellow	gray	black
PVC (UL/CSA)		013	213	613	013	213	613
PUR/PVC (UL/CSA)		023	223	623	023	223	623
PUR (UL/CSA)		033	233	633	033	233	633
PUR (UL/CSA), welding spark res.		053	253	653	053	253	653
3 Cable Length							
0.3 m		0030					
0.6 m		0060					
1.0 m		0100					
1.5 m		0150					
2.0 m		0200					
Technical Data							
Operating voltage		max. 250 V AC/DC					
Protection		IP67 inserted and tightened (EN 60529)					
Temperature range		-25...+85 °C, depending on cable quality					
Article No.							
The composition of your article number is explained on page 3.1.i		7 0 0 0					
		7 0 0 5			M12 Lite (plastic hexagonal screw) on request		
		1 Form			2 Cable Type		
					3 Cable Length		
Notes							
		Other versions on request. Differing cable lengths up to 2 m can be ordered in 0.2 m steps, from 2 m on in 0.5 m steps.					

M12 ROUND PLUG CONNECTORS

Connection cables

- M12 - M12
- shielded

Male

straight

Female

straight



Approvals:  

1 Form	40481	40501	40521
Type	3-pole	4-pole	5-pole
Circuit diagram			
Contact layout			
2 Cable Type	Jacket Color	Jacket Color	Jacket Color
Wire diameter 0.34 mm ²	gray	gray, green	gray
PVC	317	330	348
PUR/PVC	318	331	349
PUR		820 - DESINA®	
3 Cable Length			
0.3 m	0030		
0.6 m	0060		
1.0 m	0100		
1.5 m	0150		
2.0 m	0200		
Technical Data			
Operating voltage	max. 60 V AC/DC		
Protection	IP67 inserted and tightened (EN 60529)		
Temperature range	-25...+85 °C, depending on cable quality		
Article No.			
The composition of your article number is explained on page 3.1.i	<div style="display: flex; justify-content: space-around; align-items: center;"> 7 0 0 0 - - - - </div>		
	1	2	3
	Form	Cable Type	Cable Length
Notes	Other versions on request. Differing cable lengths up to 2 m can be ordered in 0.2 m steps, from 2 m on in 0.5 m steps.		

M12 Round Plug Connectors

M12 ROUND PLUG CONNECTORS

Connection cables

– M12 - M8

Male

straight

Female

straight



Approvals:   

* only for products with UL/CSA approved cable

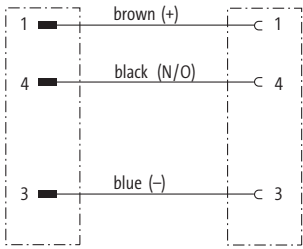
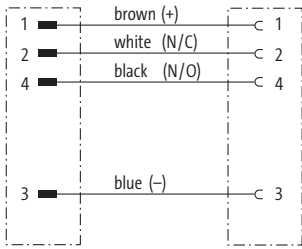
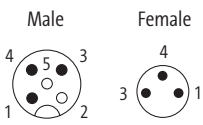
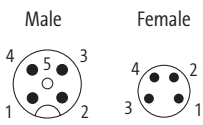
1 Form	40561	me	40581	me		
Type	3-pole		4-pole			
Circuit diagram						
Contact layout						
2 Cable Type	Jacket Color		Jacket Color			
Wire diameter 0.25 mm ²	yellow	gray	black	yellow	gray	black
PVC (UL/CSA)	010	210	610	011	211	611
PUR/PVC (UL/CSA)	020	220	620	021	221	621
PUR (UL/CSA)	030	230	630	031	231	631
PUR (UL/CSA), welding spark res.	050	250	650	051	251	651
3 Cable Length						
1.0 m	0100					
1.5 m	0150					
2.0 m	0200					
0.3 m	0030					
0.6 m	0060					
Technical Data						
Operating voltage	max. 60 V AC/DC			max. 30 V AC/DC		
Protection	IP67 inserted and tightened (EN 60529)					
Temperature range	-25...+85 °C, depending on cable quality					
Article No.						
The composition of your article number is explained on page 3.1.i	<div style="display: flex; justify-content: space-around; align-items: center;"> 7 0 0 0 - _ - _ _ </div>					
	1 Form		2 Cable Type		3 Cable Length	
Notes	Other versions on request. Differing cable lengths up to 2 m can be ordered in 0.2 m steps, from 2 m on in 0.5 m steps.					

M12 ROUND PLUG CONNECTORS

Field-wireable
– IDC terminals

Male
straight

Female
straight



Approvals:

M12 Round Plug Connectors

1 Form	12461 me \times	12481 me \times	12581 me \times	12601 me \times
Type	3-pole	4-pole	3-pole	4-pole
Circuit diagram				
Connection cross section	0.25...0.5 mm ²			
Contact layout	<p>Male</p>	<p>Male</p>	<p>Female</p>	<p>Female</p>
Technical Data				
Operating voltage	max. 32 V AC/DC			
Operating current per contact	max. 4 A			
Connection cross section	0.25...0.5 mm ² (conductor diameter min. 0.1 mm)			
Sealing range (cable diameter)	4...5.1 mm			
Wire isolation	PVC, PP, TPE			
Outer wire diameter	1.2...1.6 mm			
Locking of ports	Screw thread M12 × 1 mm (recommended torque 0.6 Nm) self-securing			
Protection	IP67 inserted and tightened (EN 60529)			
Temperature range	-25...+85 °C			
Article No.				
The composition of your article number is explained on page 3.1.i	<p><u>7 0 0 0</u> - <u> </u> - <u>0 0 0</u> <u>0 0 0 0</u></p>			
	<p><u>7 0 0 5</u> M12 Lite (plastic hexagonal screw) on request</p>			
	1 Form			
Notes	Other versions on request.			

M12 ROUND PLUG CONNECTORS

Field-wireable

– IDC terminals

Male

straight, compact



Female

straight, compact



Approvals:

1 Form	12491	me \times	12611	me \times
Type	4-pole		4-pole	
Circuit diagram				
Connection cross section	0.14...0.34 mm ²			
Contact layout	<p>Male</p>		<p>Female</p>	
Technical Data				
Operating voltage	max. 32 V AC/DC			
Operating current per contact	max. 4 A			
Connection cross section	0.14...0.34 mm ² (conductor diameter min. 0.1 mm)			
Sealing range (cable diameter)	2.9...5.1 mm			
Wire isolation	PVC, PP, TPE			
Outer wire diameter	1.0...1.6 mm			
Locking of ports	Screw thread M12 × 1 mm (recommended torque 0.6 Nm) self-securing			
Protection	IP67 inserted and tightened (EN 60529)			
Temperature range	-25...+85 °C			
Article No.				
The composition of your article number is explained on page 3.1.i	<p style="text-align: center;"> 7 0 0 0 - _____ - 0 0 0 0 0 0 0 </p>			
	1 Form			
Notes	Other versions on request.			

M12 ROUND PLUG CONNECTORS

Field-wireable
– IDC terminals

Female
90° with LED



Approvals:

1 Form	12671	me	12691	me
Type	3-pole with 2 × LED (PNP)		4-pole with 3 × LED (PNP)	
Circuit diagram				
Connection cross section	0.25...0.5 mm ²			
Contact layout	Female 		Female 	
Technical Data				
Operating voltage	24 V DC ±25 %			
Operating current per contact	max. 4 A			
Connection cross section	0.25...0.5 mm ² (conductor diameter min. 0.1 mm)			
Sealing range (cable diameter)	4...5.1 mm			
Wire isolation	PVC, PP, TPE			
Outer wire diameter	1.2...1.6 mm			
Locking of ports	Screw thread M12 × 1 mm (recommended torque 0.6 Nm) self-securing			
Protection	IP65 and IP67 when plugged and screwed down (EN 60529)			
Temperature range	-25...+85 °C			
Article No.				
The composition of your article number is explained on page 3.1.i	7 0 0 0		0 0 0	
	7 0 0 5		M12 Lite (plastic hexagonal screw) on request	
	1 Form			
Notes	Other versions on request.			

M12 ROUND PLUG CONNECTORS

Field-wireable
– IDC terminals

Male
straight



Approvals:

M12 Round Plug Connectors

1 Form	12501	me \times	12521	me \times	12515	me \times
Type	3-pole		4-pole		4-pole	
Circuit diagram						
Connection cross section	0.5...1.0 mm ²					
Contact layout	<p>Male</p>		<p>Male</p>		<p>Male</p>	
Technical Data						
Operating voltage	max. 32 V AC/DC					
Operating current per contact	max. 4 A					
Connection cross section	0.5...1.0 mm ² (conductor diameter min. 0.1 mm)					
Sealing range (cable diameter)	5.5...8 mm					
Wire isolation	PVC, PP, TPE					
Outer wire diameter	1.6...2.0 mm					
Locking of ports	Screw thread M12 × 1 mm (recommended torque 0.6 Nm) self-securing					
Protection	IP67 inserted and tightened (EN 60529)				IP65 and IP67 when plugged and screwed down (EN 60529)	
Temperature range	-25...+85 °C					
Article No.						
The composition of your article number is explained on page 3.1.i	7 0 0 0		-		0 0 0	
	7 0 0 5		M12 Lite (plastic hexagonal screw) on request			
	1 Form					
Notes						
Other versions on request.						

M12 ROUND PLUG CONNECTORS

Field-wireable
– IDC terminals

Female
straight



Approvals:

1 Form	12621	me	12641	me
Type	3-pole		4-pole	
Circuit diagram				
Connection cross section	0.5...1.0 mm ²			
Contact layout	Female 		Female 	
Technical Data				
Operating voltage	max. 32 V AC/DC			
Operating current per contact	max. 4 A			
Connection cross section	0.5...1.0 mm ² (conductor diameter min. 0.1 mm)			
Sealing range (cable diameter)	5.5...8 mm			
Wire isolation	PVC, PP, TPE			
Outer wire diameter	1.6...2.0 mm			
Locking of ports	Screw thread M12 × 1 mm (recommended torque 0.6 Nm) self-securing			
Protection	IP67 inserted and tightened (EN 60529)			
Temperature range	-25...+85 °C			
Article No.				
The composition of your article number is explained on page 3.1.i	7 0 0 0		0 0 0	
	7 0 0 5		M12 Lite (plastic hexagonal screw) on request	
	1 Form			
Notes	Other versions on request.			

M12 ROUND PLUG CONNECTORS

Field-wireable
– Screw terminals

Male
straight

Female
straight



Approvals:

M12 Round Plug Connectors

1 Form	12701 me✘	12721 me✘	12901 me✘	12921 me✘
Approvals	cCSAus	cCSAus	CSA	cCSAus
Type	4-pole	5-pole	4-pole	5-pole
Circuit diagram				
Sealing range (cable diameter)	4...6 mm			
Contact layout	<p>Male</p>	<p>Male</p>	<p>Female</p>	<p>Female</p>
Technical Data				
Operating voltage	max. 250 V AC/DC	max. 125 V AC/DC	max. 250 V AC/DC	max. 125 V AC/DC
Operating current per contact	max. 4 A			
Connection cross section	max. 0.75 mm ²			
Sealing range (cable diameter)	4...6 mm			
Locking of ports	Screw thread M12 × 1 mm (recommended torque 0.6 Nm) self-securing			
Protection	IP67 inserted and tightened (EN 60529)			
Temperature range	-25...+85 °C			
Article No.				
The composition of your article number is explained on page 3.1.i	<u>7</u> <u>0</u> <u>0</u> <u>0</u>	-	-	<u>0</u> <u>0</u> <u>0</u> <u>0</u>
	1 Form			
Notes	Other versions on request.			

T-COUPLERS VERSATILE ADAPTERS

- Slimline saves space
- Minimizes wiring efforts
- Many different configurations

T-COUPLERS FOR PERFECT SYSTEM INSTALLATIONS

Increasingly, automation requires a large number of sensors and with each sensor comes more wiring.

By using T-couplers you reduce the number of cables required and you can combine inputs and outputs depending on the application. Thanks to the slim design, you can connect several M12 ports to our Cube module. The handy torque wrench makes installation easy even in tight spaces and guarantees IP67 seals.

The slimline T-couplers feature a new female screw connection which makes the connection even safer and easier.

Connections



M12 male
T-coupler

M8 female
M12 female
T-coupler

see onlineshop.murrelektronik.com/en



M12 male
T-coupler (slimline)

M8 female
M12 female
T-Coupler (slimline)

Page 3.3.2



7/8" male
Power distributor

7/8" female
Power distributor

see onlineshop.murrelektronik.com/en

M12 ROUND PLUG CONNECTORS

Field-wireable

– Screw terminals

Male

90°



Female

90°



Approvals:

1 Form	12821 me×	12841 me×	12981 me×	13001 me×
Type	4-pole	5-pole	4-pole	5-pole
Circuit diagram				
Sealing range (cable diameter)	4...6 mm			
Contact layout	Male 	Male 	Female 	Female
Technical Data				
Operating voltage	max. 250 V AC/DC	max. 125 V AC/DC	max. 250 V AC/DC	max. 125 V AC/DC
Operating current per contact	max. 4 A			
Connection cross section	max. 0.75 mm ²			
Sealing range (cable diameter)	4...6 mm			
Locking of ports	Screw thread M12 × 1 mm (recommended torque 0.6 Nm) self-securing			
Protection	IP67 inserted and tightened (EN 60529)			
Temperature range	-25...+85 °C			
Article No.				
The composition of your article number is explained on page 3.1.i	<u>7</u> <u>0</u> <u>0</u> <u>0</u>	-	-	<u>0</u> <u>0</u> <u>0</u> <u>0</u>
	1 Form			
Notes	Other versions on request.			

M12 ROUND PLUG CONNECTORS

Field-wireable
– Screw terminals

Y connector
Male straight



Approvals:

M12 Round Plug Connectors

1 Form	12781	12801	meX	
Type	4-pole	5-pole		
Circuit diagram				
Sealing range (cable diameter)	2.1...3/4...5 mm			
Contact layout	<p>Male</p>	<p>Male</p>		
Technical Data				
Operating voltage	max. 250 V AC/DC		max. 125 V AC/DC	
Operating current per contact	max. 4 A			
Connection cross section	max. 0.75 mm ²			
Sealing range (cable diameter)	2.1...3/4...5 mm (2 cable entries)			
Protection	IP67 inserted and tightened (EN 60529)			
Temperature range	-25...+85 °C			
Article No.				
The composition of your article number is explained on page 3.1.i	<u>7</u> <u>0</u> <u>0</u> <u>0</u>	- - - -	<u>0</u> <u>0</u> <u>0</u>	<u>0</u> <u>0</u> <u>0</u> <u>0</u>
	1 Form			
Notes	Other versions on request.			

T-COUPLERS VERSATILE ADAPTERS

- Slimline saves space
- Minimizes wiring efforts
- Many different configurations

T-COUPLERS FOR PERFECT SYSTEM INSTALLATIONS

Increasingly, automation requires a large number of sensors and with each sensor comes more wiring.

By using T-couplers you reduce the number of cables required and you can combine inputs and outputs depending on the application. Thanks to the slim design, you can connect several M12 ports to our Cube module. The handy torque wrench makes installation easy even in tight spaces and guarantees IP67 seals.

The slimline T-couplers feature a new female screw connection which makes the connection even safer and easier.

Connections



M12 male
T-coupler

M8 female
M12 female
T-coupler

see onlineshop.murrelektronik.com/en



M12 male
T-coupler (slimline)

M8 female
M12 female
T-Coupler (slimline)

Page 3.3.2



7/8" male
Power distributor

7/8" female
Power distributor

see onlineshop.murrelektronik.com/en

T-COUPPLERS M8, M12, 7/8"

Connection cables

– M12 - M8

T-coupler (Slimline)

Male straight to female straight

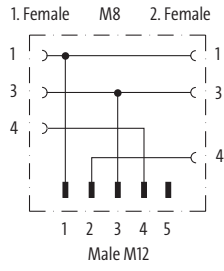
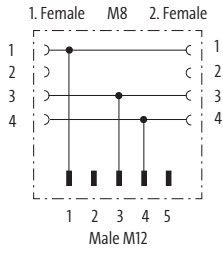
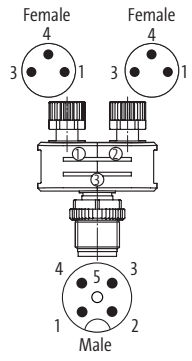
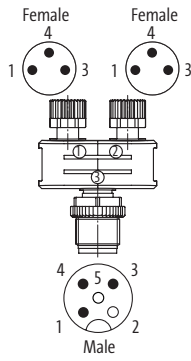

Approvals:  

1 Form	41211	41231
<p>Type</p> <p>Circuit diagram</p>	<p>4-pole</p> 	<p>3-pole</p> 
<p>Contact layout</p>		
<p>Holding plate</p>	<p>7000-99061-0000000</p>	
<p>Holding plate and mounting set</p>	<p>7000-99062-0000000</p>	
<p>Technical Data</p>		
<p>Operating voltage</p>	<p>max. 60 V AC/DC</p>	
<p>Operating current per contact</p>	<p>max. 4 A</p>	
<p>Locking of ports</p>	<p>Screw thread M8/M12 × 1 mm (recommended torque 0.4/0.6 Nm), self-securing</p>	
<p>Protection</p>	<p>IP65 and IP67 when plugged and screwed down (EN 60529)</p>	
<p>Temperature range</p>	<p>-25...+85 °C</p>	
<p>Article No.</p>		
<p>The composition of your article number is explained on page 3.1.i</p>	<p style="text-align: center;"><u>7 0 0 0</u> - <u> </u> - <u>0 0 0</u> <u>0 0 0 0</u></p>	
<p>1 Form</p>		
<p>Notes</p>	<p>Other versions on request.</p>	

T-couplers M8, M12, 7/8"

T-COUPLERS M8, M12, 7/8"

Connection cables

- M12 - M12

T-coupler (Slimline)

Male straight to female straight



Approvals:  

T-couplers M8, M12, 7/8"

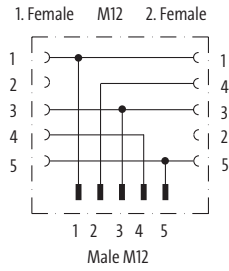
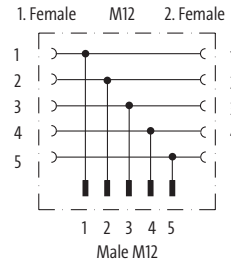
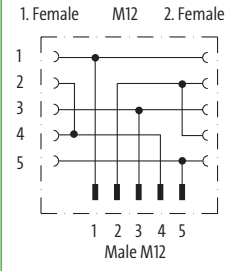
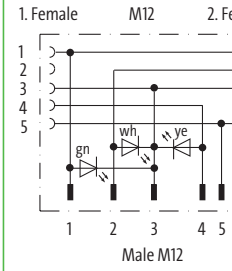
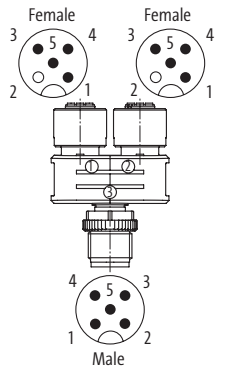
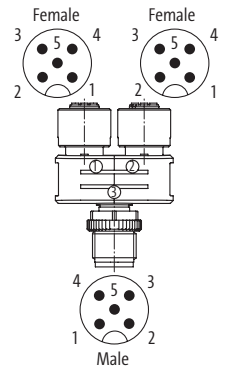
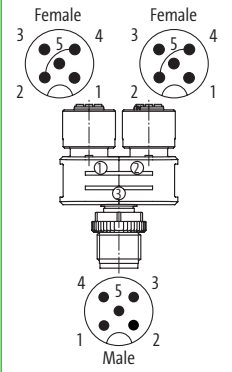
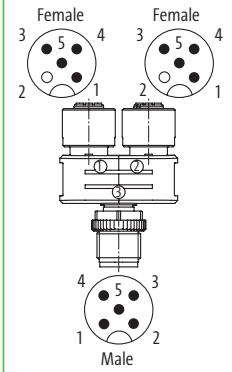
1 Form	41131	41151	41191	41135
Type	5-pole	5-pole	5-pole	5-pole with 3 × LED (PNP)
Circuit diagram				
Contact layout				
Holding plate	7000-99061-0000000			
Holding plate and mounting set	7000-99062-0000000			
Technical Data				
Operating voltage	max. 60 V AC/DC		24 V DC ±25 %	
Operating current per contact	max. 4 A			
Locking of ports	Screw thread M12 × 1 mm (recommended torque 0.6 Nm) self-securing			
Protection	IP65 and IP67 when plugged and screwed down (EN 60529)		IP67 inserted and tightened (EN 60529)	
Temperature range	-25...+85 °C			
Article No.				
The composition of your article number is explained on page 3.1.i	<u>7</u> <u>0</u> <u>0</u> <u>0</u>	-	-	<u>0</u> <u>0</u> <u>0</u> <u>0</u>
	1	Form		
Notes	Other versions on request.			



FLANGE CONNECTORS READY FOR ANYTHING

- Molded PP wires
- Anti-twist protection ensures convenient assembly
- Front and rear mounting

COMPREHENSIVE RANGE TO CUSTOMER NEEDS

Murrelektronik has a wide range of M12 flange plug connectors and offers solutions for all kinds of applications. A special characteristic of Murrelektronik's flange connectors is the molded polypropylene wires in the metal housing. Short-circuits can be avoided with this protection. An integrated over-rotation protection makes assembly easy.

Don't see what you needed? Visit onlineshop.murrelektronik.com for other styles including V4A Stainless Steel for Food & Beverage applications.

M8



Male/female

- 3-pole
- 4-pole

see onlineshop.murrelektronik.com/en

M12



Male/female

- 4-pole
- 5-pole
- 8-pole

Page 3.4.2



Control Cabinet Entry System

Male/female

- 5-pole
- 5-pole, B-coded (for Profibus/Interbus)
- 6-pole (for Cube67)
- 8-pole *see onlineshop.murrelektronik.com/en*

7/8"

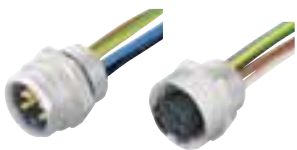

Male/female

- 4-pole
- 5-pole

see onlineshop.murrelektronik.com/en

FLANGE CONNECTORS

With multi-strand wire

– M12

Flange M12 female

Front mounting



1 Form	13541	13561	17181
Type	4-pole	5-pole	8-pole
Circuit diagram			
Contact layout	Female 	Female 	Female
2 Wires			
Wire diameter 0.34 mm ²	multi-colored	multi-colored	multi-colored
TPE-S	971	972	
Wire diameter 0.25 mm ²			
TPE-S			973
Hexagonal nut M16 × 1.5	7000-13581-0000000		
3 Wires Length			
0.2 m	0020		
0.5 m	0050		
1.0 m	0100		
Technical Data			
Operating voltage	max. 250 V AC/DC	max. 125 V AC/DC	max. 60 V AC/DC
Protection	IP67 inserted and tightened (EN 60529)		
Temperature range	-25...+85 °C		
Article No.			
The composition of your article number is explained on page 3.1.i	<div style="display: flex; justify-content: space-around; align-items: center;"> 7 0 0 0 - - - - </div>		
	1 Form	2 Wires	3 Wires Length
Notes	Other versions on request.		

Flange Connectors

FIELD BUS CONNECTORS

- Wide range of M8, M12 and RJ45 connectors
- 360° shielding
- Flex rated cables

FROM AS INTERFACE TO ETHERNET TO PROFIBUS AND MORE...

Murrelektronik offers connection accessories for the fieldbus products. In addition to both field-wireable M12 and RJ45 connectors we have a wide range of pre-wired, molded models. Both the 15° locking mechanism and the PUR molding ensure an IP65/67 rated connection which make the connectors suitable for many aggressive industrial environments.



PROFIBUS



With open ended wires

M12 male/female (shielded)
• Straight/90°

Page 3.5.1

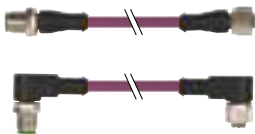

Connection Cables

M12 male – M12 female (shielded)
• Straight/90°

Page 3.5.3

DeviceNet, CANopen

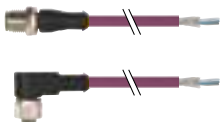

With open ended wires

M12 male/female (shielded)
• Straight/90°

Page 3.5.4

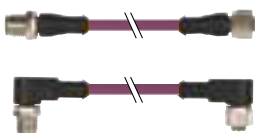

Connection Cables

M12 male – M12 female (shielded)
• Straight/90°

Page 3.5.6

EtherNet, EtherCAT, PROFINET



With open ended wires

M8 male (shielded)

- Straight/90°

Connection Cables

M8 male – M8 male (shielded)

- Straight/90°

[see onlineshop.murrelektronik.com/en](http://onlineshop.murrelektronik.com/en)

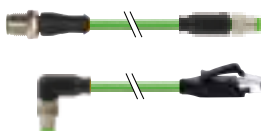

Connection Cables

M12 male – M8 male (shielded)

- Straight

Connection Cables

M8 male – RJ45 male (shielded)

- Straight/90°

[see onlineshop.murrelektronik.com/en](http://onlineshop.murrelektronik.com/en)

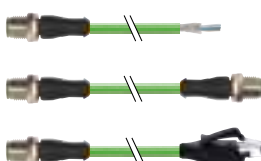

With open ended wires

M12 male (shielded)

- Straight/90°

Connection Cables

M12 male – M12 male / RJ45 male (shielded)

- Straight/90°

Page 3.5.7



With open ended wires

RJ45 male (shielded)

- Straight/90°

Connection Cables

RJ45 male – RJ45 male (shielded)

- Straight/90°

Page 3.5.10

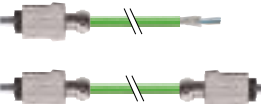

With open ended wires

RJ45 male Push Pull

- Straight

Connection Cables

RJ45 male Push Pull – RJ45 male Push Pull

- Straight

[see onlineshop.murrelektronik.com/en](http://onlineshop.murrelektronik.com/en)

Cube67, 6-pole

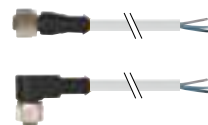

With open ended wires

M12 female

- Straight/90°

[see onlineshop.murrelektronik.com/en](http://onlineshop.murrelektronik.com/en)

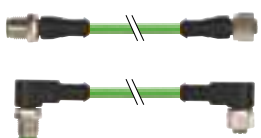

Connection Cables

M12 male – M12 female (shielded)

- Straight/90°

Page 3.5.11

AS Interface



Connection Cables
for MASI68

M12 male – M12 female

- Straight

[see onlineshop.murrelektronik.com/en](http://onlineshop.murrelektronik.com/en)

NOTES

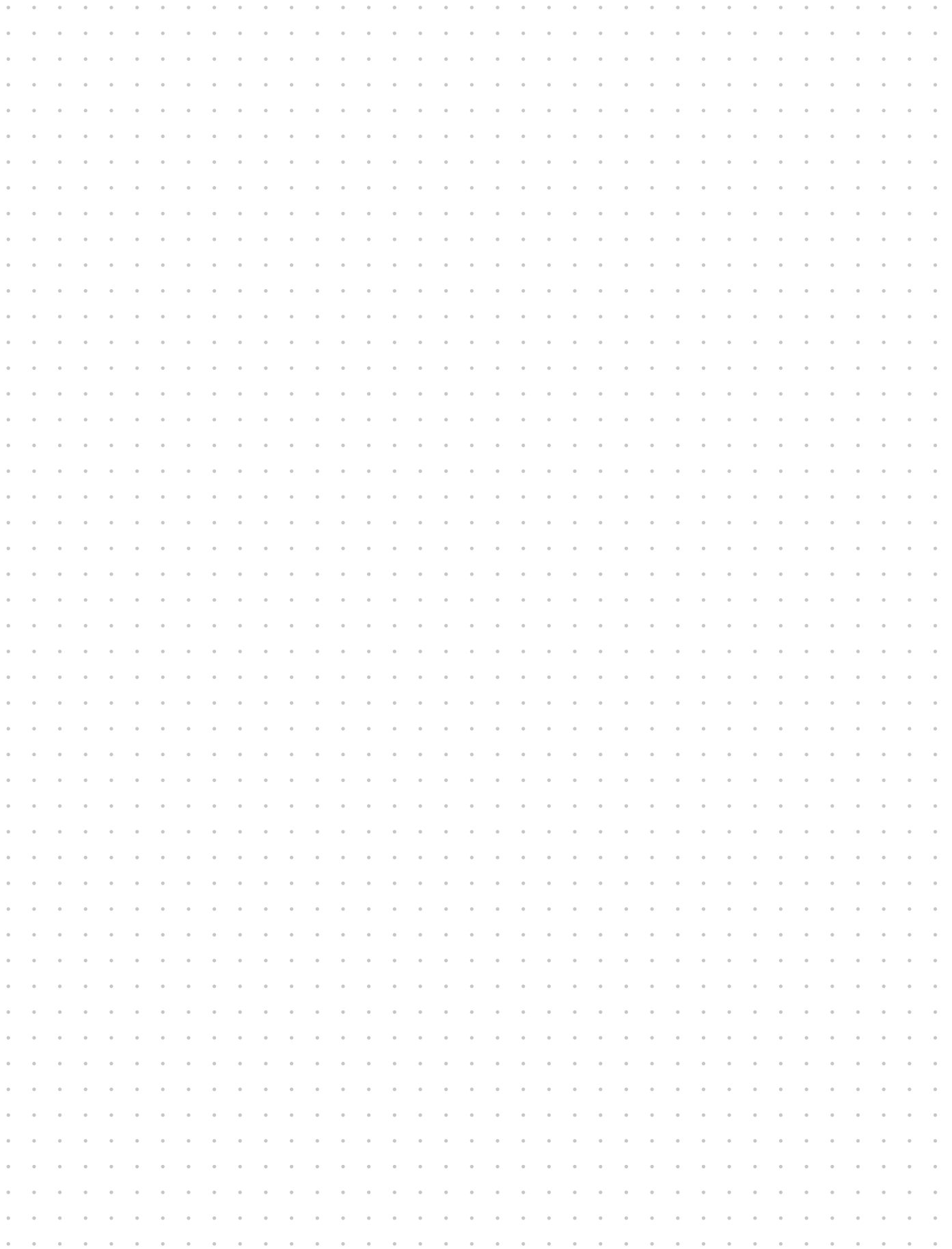

FIELD BUS CONNECTORS

PROFIBUS

– with open ended wires M12

– shielded, B-coded



Approvals:

Male

straight



Male

90°



1 Form	14051	14081
Type	2-pole	2-pole
Circuit diagram		
Contact layout	<p>Male</p>	
2 Cable Type	Jacket Color	Jacket Color
1x2xØ 0.64mm	violet	violet
PUR (UL/CSA)	841	841
PUR (UL/CSA), Highspeed C-track	840	840
PUR (UL/CSA), Torsion	843	843
PVC (UL/CSA)	850	850
Terminator M12	7000-14041-0000000	
Flange M12, B-coded	7000-44111-0000000	
3 Cable Length		
1.5 m	0150	
3.0 m	0300	
5.0 m	0500	
7.5 m	0750	
10.0 m	1000	
Technical Data		
Operating voltage	max. 60 V AC/DC	
Protection	IP67 inserted and tightened (EN 60529)	
Temperature range	-25...+85 °C, depending on cable quality	
Article No.		
The composition of your article number is explained on page 3.1.i	<div style="display: flex; justify-content: space-around; align-items: center;"> 7 0 0 0 - - - - - </div>	
	1 Form	2 Cable Type
		3 Cable Length
Notes	<p>Other versions on request. Differing cable lengths up to 2 m can be ordered in 0.2 m steps, from 2 m on in 0.5 m steps. Connection accessories and general accessories can be found at the end of chapter 3.6.</p>	

FIELDBUS CONNECTORS

PROFIBUS

- with open ended wires M12
- shielded, B-coded



Approvals:

Female
straight



Female
90°



1 Form	14061	14071	
	Type 2-pole	Type 2-pole	
Circuit diagram			
Contact layout			
2 Cable Type	Jacket Color	Jacket Color	
	1x2xØ 0.64mm	violet	violet
	PUR (UL/CSA)	841	841
	PUR (UL/CSA), Highspeed C-track	840	840
	PUR (UL/CSA), Torsion	843	843
	PVC (UL/CSA)	850	850
	Terminator M12	7000-14041-0000000	
Flange M12, B-coded	7000-44111-0000000		
3 Cable Length	1.5 m	0150	
	3.0 m	0300	
	5.0 m	0500	
	7.5 m	0750	
	10.0 m	1000	
	Technical Data		
Operating voltage	max. 60 V AC/DC		
Protection	IP67 inserted and tightened (EN 60529)		
Temperature range	-25...+85 °C, depending on cable quality		
Article No.			
The composition of your article number is explained on page 3.1.i	<div style="display: flex; justify-content: space-around; align-items: center;"> 7 0 0 0 - - </div>		
	1 Form	2 Cable Type	
		3 Cable Length	
Notes	Other versions on request. Differing cable lengths up to 2 m can be ordered in 0.2 m steps, from 2 m on in 0.5 m steps. Connection accessories and general accessories can be found at the end of chapter 3.6.		

Fieldbus Connectors

FIELD BUS CONNECTORS

PROFIBUS

– Connection cables M12 - M12

– shielded, B-coded



Approvals:

Male
straight

Female
straight

Male
90°

Female
90°



1 Form	44001	44021
---------------	--------------	--------------

Type	2-pole	2-pole
------	--------	--------

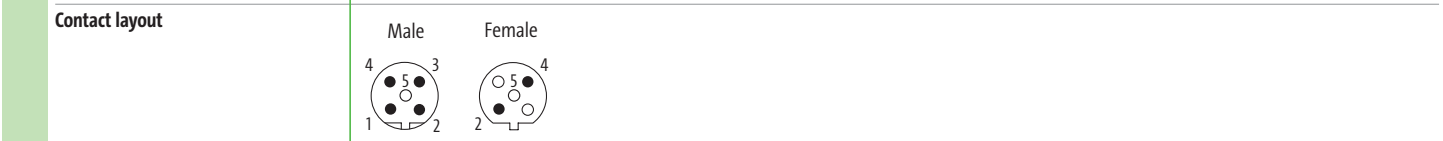
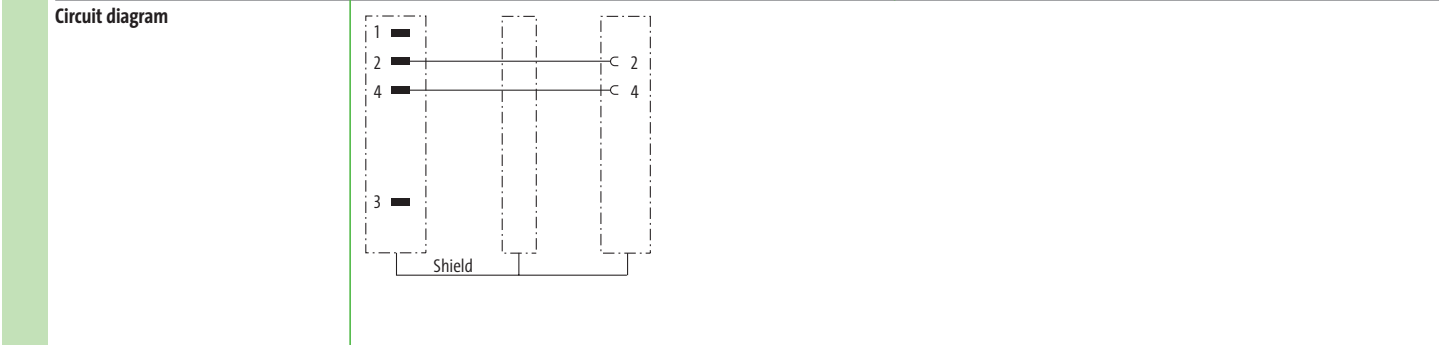

2 Cable Type	Jacket Color	Jacket Color
---------------------	---------------------	---------------------

1x2xØ 0.64mm	violet	violet
PUR (UL/CSA)	841	841
PUR (UL/CSA), Highspeed C-track	840	840
PUR (UL/CSA), Torsion	843	843
PVC (UL/CSA)	850	850

Terminator M12	7000-14041-0000000
Flange M12, B-coded	7000-44111-0000000

3 Cable Length	
-----------------------	--

0.3 m	0030
0.6 m	0060
1.0 m	0100
1.5 m	0150
2.0 m	0200

Technical Data	
-----------------------	--

Operating voltage	max. 60 V AC/DC
Protection	IP67 inserted and tightened (EN 60529)
Temperature range	-25...+85 °C, depending on cable quality

Article No.	
--------------------	--

The composition of your article number is explained on page 3.1.i

7 0 0 0	-	-	-
----------------	---	---	---

1 Form	2 Cable Type	3 Cable Length
---------------	---------------------	-----------------------

Notes

Other versions on request. Differing cable lengths up to 2 m can be ordered in 0.2 m steps, from 2 m on in 0.5 m steps.
Connection accessories and general accessories can be found at the end of chapter 3.6.

FIELDBUS CONNECTORS

DeviceNet, CANopen

– with open ended wires M12

– shielded



Male

straight



Male

90°



1 Form

13105

13125

Type
Circuit diagram

5-pole

5-pole

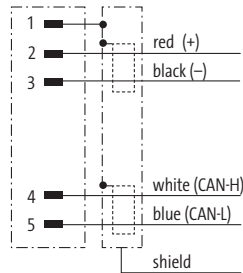

Contact layout

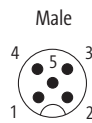

2 Cable Type

Jacket Color

Jacket Color

2x0.25 + 2x0.34 mm²
PUR (UL/CSA)

violet
803

violet
803

Control cabinet entry system M12

7000-42111-0000000

3 Cable Length

1.5 m	0150
3.0 m	0300
5.0 m	0500
7.5 m	0750
10.0 m	1000

Technical Data

Operating voltage	max. 60 V AC/DC
Protection	IP67 inserted and tightened (EN 60529)
Temperature range	-25...+85 °C, depending on cable quality

Article No.

The composition of your article number is explained on page 3.1.i

7 0 0 0 - - - - -

1 Form

2 Cable Type

3 Cable Length

Notes

Other versions on request. Differing cable lengths up to 2 m can be ordered in 0.2 m steps, from 2 m on in 0.5 m steps. Connection accessories and general accessories can be found at the end of chapter 3.6.

FIELDBUS CONNECTORS

DeviceNet, CANopen

– with open ended wires M12

– shielded



Female

straight



Female

90°



1 Form		13225	13251
Type		5-pole	5-pole
Circuit diagram			
Contact layout	<p>Female</p>		
2 Cable Type		Jacket Color	Jacket Color
2x0.25 + 2x0.34 mm ² PUR (UL/CSA)		violet 803	violet 803
Control cabinet entry system M12		7000-42111-0000000	
3 Cable Length			
1.5 m		0150	
3.0 m		0300	
5.0 m		0500	
7.5 m		0750	
10.0 m		1000	
Technical Data			
Operating voltage		max. 60 V AC/DC	
Protection		IP67 inserted and tightened (EN 60529)	
Temperature range		-25...+85 °C, depending on cable quality	
Article No.			
The composition of your article number is explained on page 3.1.i		<div style="display: flex; justify-content: space-around; align-items: center;"> 7 0 0 0 - _ _ _ _ _ _ </div>	
		1 Form	2 Cable Type
		3 Cable Length	
Notes		Other versions on request. Differing cable lengths up to 2 m can be ordered in 0.2 m steps, from 2 m on in 0.5 m steps. Connection accessories and general accessories can be found at the end of chapter 3.6.	

FIELDBUS CONNECTORS

DeviceNet, CANopen

– Connection cables M12 - M12

– shielded



Male
straight

Female
straight



Male
90°

Female
90°



1 Form	40531	40551
---------------	--------------	--------------

Type	5-pole	5-pole
------	--------	--------

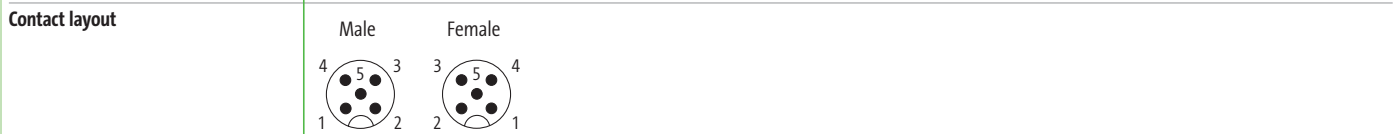
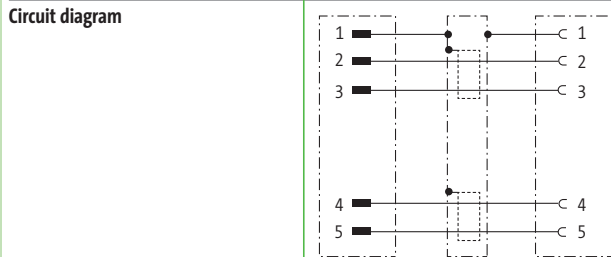

2 Cable Type	Jacket Color	Jacket Color
---------------------	---------------------	---------------------

2x0.25 + 2x0.34 mm ² PUR (UL/CSA)	violet 803	violet 803
---	---------------	---------------

Control cabinet entry system M12	7000-42111-0000000
----------------------------------	--------------------

3 Cable Length	
-----------------------	--

1.5 m	0150
3.0 m	0300
5.0 m	0500
7.5 m	0750
10.0 m	1000

Technical Data	
-----------------------	--

Operating voltage	max. 60 V AC/DC
Protection	IP67 inserted and tightened (EN 60529)
Temperature range	-25...+85 °C, depending on cable quality

Article No.	
--------------------	--

The composition of your article number is explained on page 3.1.i

<u>7</u> <u>0</u> <u>0</u> <u>0</u>	-	-	-
-------------------------------------	---	---	---

1 Form	2 Cable Type	3 Cable Length	
---------------	---------------------	-----------------------	--

Notes	
--------------	--

Other versions on request. Differing cable lengths up to 2 m can be ordered in 0.2 m steps, from 2 m on in 0.5 m steps. Connection accessories and general accessories can be found at the end of chapter 3.6.

FIELDBUS CONNECTORS

Ethernet CAT 5e

– with open ended wires M12

– shielded, D-coded

EtherNet/IP[®] conformance tested EtherCAT[™]

PROFI
NET

Approvals:   

Male

straight



Male

90°



1 Form

14541

14561

Type

4-pole

4-pole

Circuit diagram

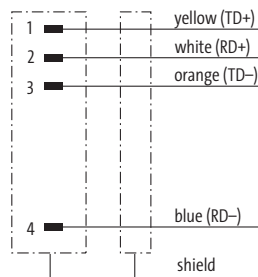

Contact layout

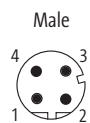

2 Cable Type

Jacket Color

Jacket Color

Wire diameter 0.34 mm²

PUR (UL/CSA), halogen free

PUR (UL/CSA), Torsion

PUR (UL/CSA)

green

violet

green

violet

794

794

793

793

796

798

796

798

3 Cable Length

1.5 m

0150

3.0 m

0300

5.0 m

0500

7.5 m

0750

10.0 m

1000

Technical Data

Operating voltage

60 V DC

Protection

IP65 and IP67 when plugged and screwed down (EN 60529)

IP67 inserted and tightened (EN 60529)

Temperature range

-25...+85 °C, depending on cable quality

Article No.

The composition of your article number is explained on page 3.1.i

7 0 0 0 - - - - -

1 Form

2 Cable Type

3 Cable Length

Notes

Other versions on request. Differing cable lengths up to 2 m can be ordered in 0.2 m steps, from 2 m on in 0.5 m steps. Connection accessories and general accessories can be found at the end of chapter 3.6.

FIELDBUS CONNECTORS

Ethernet CAT 5e

– Connection cables M12 - M12

– shielded, D-coded

EtherNet[√]IP[™] conformance tested EtherCAT[™]

PROFI[®] NET[™]

Approvals:  

Male

straight

Male

straight

Male

90°

Male

90°



1 Form	4 4 5 1 1	4 4 5 6 1
	4-pole	4-pole
Circuit diagram		
Contact layout		
2 Cable Type	Jacket Color	Jacket Color
Wire diameter 0.34 mm ²	green	violet
PUR (UL/CSA), halogen free	794	794
PUR (UL/CSA), Torsion	793	793
PUR (UL/CSA)	796	798
3 Cable Length		
1.5 m	0150	
3.0 m	0300	
5.0 m	0500	
7.5 m	0750	
10.0 m	1000	
Technical Data		
Operating voltage	60 V DC	
Protection	IP67 inserted and tightened (EN 60529)	
Temperature range	-25...+85 °C, depending on cable quality	
Article No.		
The composition of your article number is explained on page 3.1.i	<u>7</u> <u>0</u> <u>0</u> <u>0</u> - - - - - - - - - -	- - - - -
	1 Form	2 Cable Type
		3 Cable Length
Notes	Other versions on request. Differing cable lengths up to 2 m can be ordered in 0.2 m steps, from 2 m on in 0.5 m steps. Connection accessories and general accessories can be found at the end of chapter 3.6.	

Fieldbus Connectors

FIELDBUS CONNECTORS

Ethernet CAT 5e

- Connection cables
- shielded, D-coded (M12)

EtherNet/IP[®] conformance tested EtherCAT[®]

PROFI[®]
NET

Approvals:

Male M12
straight

Male RJ45
straight

Male M12
straight



1 Form	4 4 7 1 1	4 4 7 3 1
---------------	------------------	------------------

Type	4-pole	4-pole
------	--------	--------

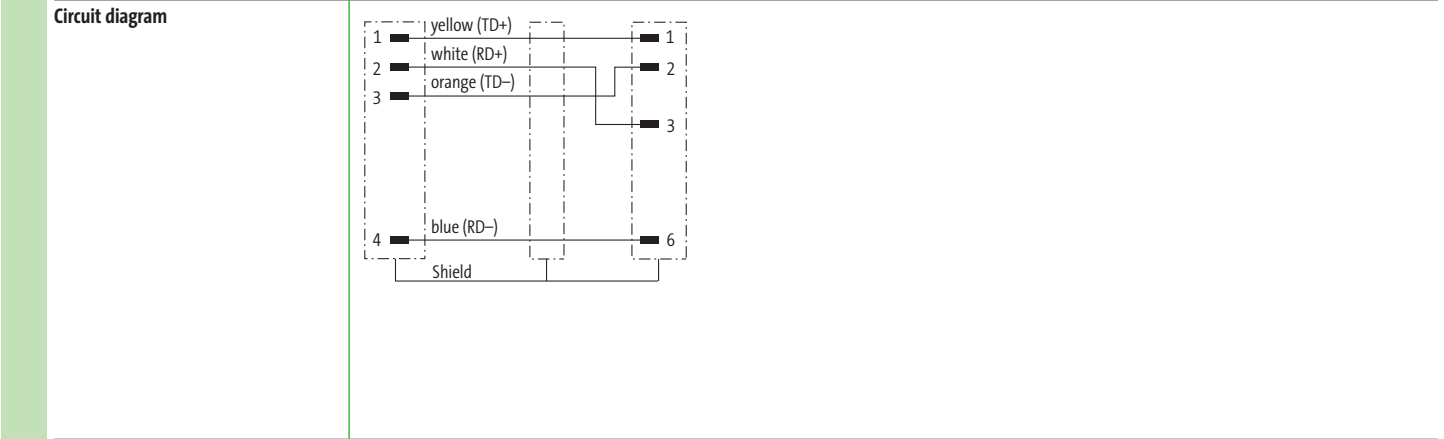

2 Cable Type	Jacket Color		Jacket Color	
	green	violet	green	violet
Wire diameter 0.34 mm ²				
PUR (UL/CSA), halogen free	794		794	
PUR (UL/CSA), Torsion	793		793	
PUR (UL/CSA)	796	798	796	798

3 Cable Length	
1.5 m	0150
3.0 m	0300
5.0 m	0500
7.5 m	0750
10.0 m	1000

Technical Data	
Operating voltage	60 V DC
Protection	IP67 (M12) - IP20 (RJ45)
Temperature range	-25...+85 °C, depending on cable quality -25...+70 °C

Article No.
The composition of your article number is explained on page 3.1.i
7 0 0 0 - - - - -

1 Form	2 Cable Type	3 Cable Length
---------------	---------------------	-----------------------

Notes

Other versions on request. Differing cable lengths up to 2 m can be ordered in 0.2 m steps, from 2 m on in 0.5 m steps.
Connection accessories and general accessories can be found at the end of chapter 3.6.

FIELDBUS CONNECTORS

Ethernet CAT 5e

– with open ended wires RJ45

– shielded

EtherNet[√]IP[™] conformance tested EtherCAT[™]

PROFI[®] NET[™]

Approvals:

Male

straight



Male

45° on top



Male

on bottom



1 Form	74101	74121	74141			
Type	4-pole	4-pole	4-pole			
Circuit diagram						
Contact layout	<p>Male</p>					
2 Cable Type	Jacket Color		Jacket Color		Jacket Color	
Wire diameter 0.34 mm ²	green	violet	green	violet	green	violet
PUR (UL/CSA), halogen free	794		794		794	
PUR (UL/CSA), Torsion	793		793		793	
PUR (UL/CSA)	796	798	796	798	796	798
3 Cable Length						
1.5 m	0150					
3.0 m	0300					
5.0 m	0500					
7.5 m	0750					
10.0 m	1000					
Technical Data						
Operating voltage	60 V DC					
Protection	IP20					
Temperature range	-25...+85 °C, depending on cable quality					
Article No.						
The composition of your article number is explained on page 3.1.i	<div style="display: flex; justify-content: space-around; align-items: center;"> 7 0 0 0 - - - - - </div>					
	1	Form	2	Cable Type	3	Cable Length
Notes	<p>Other versions on request. Differing cable lengths up to 2 m can be ordered in 0.2 m steps, from 2 m on in 0.5 m steps. Connection accessories and general accessories can be found at the end of chapter 3.6.</p>					

FIELDBUS CONNECTORS

Cube67, 6-pole

- Connection cables M12 - M12
- shielded
- Hybrid cable for communication and supply

Approvals:   

Male
straight

Female
straight

Male
90°

Female
90°



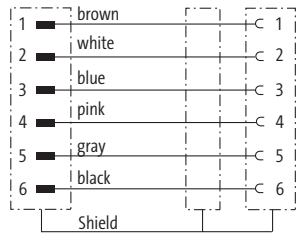
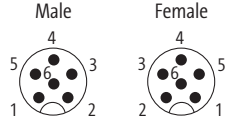

1 Form	46041	46061
Type	6-pole	6-pole
Circuit diagram		
Contact layout		
2 Cable Type	Jacket Color	Jacket Color
4x0.5 + 2x0.25 mm ²	green	green
PUR (UL/CSA)	802	802
Terminator M12	7000-15041-0000000	
Control cabinet entry system M12	7000-46111-0000000	
T-coupler M12/M12, female/male	7000-46101-0000000	
3 Cable Length		
0.15 m	0015	
0.3 m	0030	
0.6 m	0060	
1.0 m	0100	
1.5 m	0150	
2.0 m	0200	
Technical Data		
Operating voltage	max. 30 V AC/DC	
Protection	IP67 inserted and tightened (EN 60529)	
Temperature range	-25...+85 °C, depending on cable quality	
Article No.		
The composition of your article number is explained on page 3.1.i	<div style="display: flex; justify-content: space-around; align-items: center;"> 7 0 0 0 - - </div>	
	1 Form	2 Cable Type
		3 Cable Length
Notes	<p>Other versions on request. Differing cable lengths up to 2 m can be ordered in 0.2 m steps, from 2 m on in 0.5 m steps. Connection accessories and general accessories can be found at the end of chapter 3.6.</p>	

FIELDBUS CONNECTORS

Connection accessories			Art-No.
	T-coupler M12/M12, female/male straight, A-coded, 6-pole, shielded straight, A-coded, 4-pole	Cube67 additional actuator power supply MASI68 additional actuator power supply	7000-46101-0000000 7060-42701-0000000
	Male M12, field-wireable, screw terminals straight, B-coded, 5-pole, shielded	PROFIBUS, Interbus Cable diameter (6..8 mm)	7000-14001-0000000
	Female M12, field-wireable, screw terminals straight, B-coded, 5-pole, shielded	PROFIBUS, Interbus Cable diameter (6..8 mm)	7000-14021-0000000
	Male M12, field-wireable, screw terminals straight, A-coded, 5-pole	DeviceNet, CANopen Cable diameter (6..8 mm)	7000-12761-0000000
	Female M12, field-wireable, screw terminals straight, A-coded, 5-pole	DeviceNet, CANopen Cable diameter (6..8 mm)	7000-12961-0000000
	Male RJ45, CAT 5, field-wireable, IDC terminals straight, IP20, 4-pole, shielded	Ethernet CAT 5 Cable diameter (6.5..6.9 mm)	7000-99051-0000000
	Adapter M12/RJ45, CAT 5 (female/female) 90°, D-coded, 4-pole	Ethernet CAT 5	7000-99052-0000000
	Terminator M12 straight, A-coded, 5-pole straight, B-coded, 4-pole straight, A-coded, 6-pole	DeviceNet, CANopen PROFIBUS Cube67	7000-13461-0000000 7000-14041-0000000 7000-15041-0000000
	Cable drum (100 m) 1 × 2 × Ø 0.64 mm, (violet) Suitable for C-tracks	PROFIBUS	7000-C0201-8400000

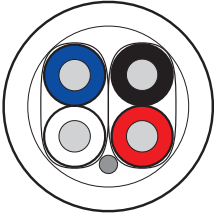
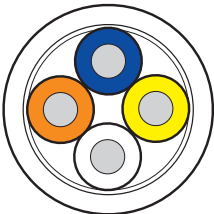
Fieldbus Connectors

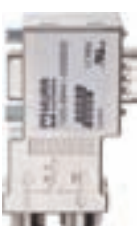
Connection accessories			Art-No.
	<p>Cable drum (100 m) 2×0.25 + 2×0.34 mm², violet Suitable for C-tracks</p>	<p>DeviceNet, CANopen</p>	<p>7000-C0201-8030000</p>
	<p>Cable drum (100 m) 2 × 2 × 0.34 mm², green Suitable for C-tracks</p>	<p>Ethernet CAT 5, PROFINET IO, EtherCAT</p>	<p>7000-C0201-7960000</p>
	<p>Bus Connection Plug 90° SUB-D9 (female), screw terminals SUB-D9 (male), screw terminals</p>	<p>CANopen PROFIBUS</p>	<p>55760 55762</p>
	<p>Bus Connection Plug 180° SUB-D9 (male), IDC terminals, flexible cable SUB-D9 (male), IDC terminals, rigid cable</p>	<p>PROFIBUS PROFIBUS</p>	<p>55583 55584</p>
	<p>Bus Connection Plug 90° SUB-D9 (male), IDC terminals, rigid cable SUB-D9 (male), IDC terminals, flexible cable</p>	<p>PROFIBUS PROFIBUS</p>	<p>55585 55587</p>
	<p>Bus Connection Plug 90° SUB-D9 (male), IDC terminals, rigid cable, programming device conn. SUB-D9 (male), IDC terminals, flexible cable, programming device conn.</p>	<p>PROFIBUS PROFIBUS</p>	<p>55586 55588</p>
	<p>Bus Connection Plug 90° SUB-D9 (male); M12 × 1, B-coded</p>	<p>PROFIBUS</p>	<p>7000-99441-0000000</p>

7/8" ROUND PLUG CONNECTORS POWERFUL AND SAFE

- Tough and reliable
- Molded connector
- Easy, safe connections with thread

THE CONNECTOR FOR LARGE POWER TRANSMISSION

Murrelektronik's 7/8" round plug connector is designed for optimum performance and the pre-wired versions can transmit power up to 12 A/contact at max. 400 V AC/DC. Of course, all connectors are 100% tested.

With Open Ended Wires

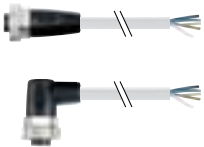

7/8" female

- Straight
- 90°

Page 3.6.1

Connection Cables



7/8" male

- Straight
- 90°

7/8" female

- Straight
- 90°

see onlineshop.murrelektronik.com/en

Field-Wireable



Insulation Displacement Technology

7/8" male/female

- Straight

see onlineshop.murrelektronik.com/en



Screw Terminals

7/8" male/female

- Straight
- 90°

see onlineshop.murrelektronik.com/en

7/8" ROUND PLUG CONNECTORS

With open ended wires

Female
straight



Female
90°

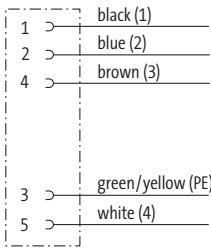
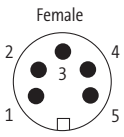

Approvals: 

1 Form	78021	78051
Type	5-pole Power cable	5-pole Power cable
Circuit diagram		
Contact layout		
2 Cable Type	Jacket Color	Jacket Color
Wire diameter 1.0 mm ² PUR/PVC	gray 965	gray 965
Wire diameter 1.5 mm ² PUR (UL/CSA)	961	961
3 Cable Length		
1.5 m	0150	
3.0 m	0300	
5.0 m	0500	
7.5 m	0750	
10.0 m	1000	
Technical Data		
Operating voltage	max. 230/400 V AC/DC	
Protection	IP67 inserted and tightened (EN 60529)	
Temperature range	-25...+85 °C, depending on cable quality	
Article No.		
The composition of your article number is explained on page 3.1.i	<div style="display: flex; justify-content: space-around; align-items: center;"> 7 0 0 0 - - </div>	
	1 Form	2 Cable Type
		3 Cable Length
Notes	Other versions on request. Differing cable lengths up to 2 m can be ordered in 0.2 m steps, from 2 m on in 0.5 m steps.	









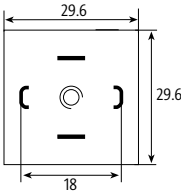

VALVE CONNECTORS MORE MODELS THAN EVER

- Molded construction – resistant to shock and vibration
- Tested to ensure reliability
- IP65 to IP67 Rated

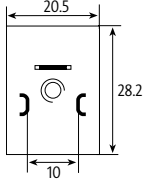
THE CONNECTOR FOR VALVES AND PRESSURE SWITCHES

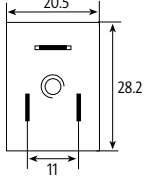
25 years ago, Murrelektronik developed and produced the first pre-wired and molded valve connector.

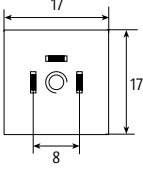
It was a revolution! Now, more than ever, Murrelektronik's valve plugs enjoy long-running success as a result of continuous improvement. A captive gasket, integrated LED status indicator and suppression are the top features of Murrelektronik's MSUD valve plug.

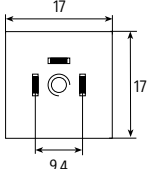
With Open Ended Wires		Valve Diagram	
		<p>MSUD Valve Connector</p> <ul style="list-style-type: none"> • Form A acc. to EN 175301-803 (ISO 4400) Pin spacing 18 mm 	<i>Page 3.7.1</i>
		<p>MSUD Valve Connector</p> <ul style="list-style-type: none"> • Form B acc. to EN 175301-803 (ISO 6952) Pin spacing 10 mm 	<i>Page 3.7.4</i>
		<p>MSUD Valve Connector</p> <ul style="list-style-type: none"> • Form BI Industrial standard Pin spacing 11 mm 	<i>see onlineshop.murrelektronik.com/en</i>
		<p>MSUD Valve Connector</p> <ul style="list-style-type: none"> • Form C acc. to EN 175301-803 (ISO 6952) Pin spacing 8 mm 	<i>see onlineshop.murrelektronik.com/en</i>
		<p>MSUD Valve Connector</p> <ul style="list-style-type: none"> • Form CI Industrial standard Pin spacing 9.4 mm 	<i>see onlineshop.murrelektronik.com/en</i>

With Open Ended Wires



Junior Timer Valve Connector

2-pole
• Straight

Page 3.7.6

Connection Cables

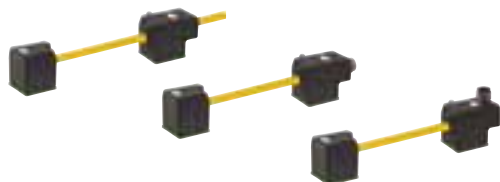

MSUD Double Valve Connector
With connection cable

• Form A
• Form B
• Form BI

M12 male
• Top connection
• Rear connection
• With connection cable

Page 3.7.7



MSUD Valve Connector

• Form A
• Form B
• Form BI
• Form C
• Form CI

M12 male
• Straight
• 90°

Page 3.7.9

* see onlineshop.murrelektronik.com/en



MSUD Valve Connector Adapter

• Form A
• Form B
• Form BI

M12 male
• Top connection
• Rear connection

see onlineshop.murrelektronik.com/en

Field-Wireable



Screw Terminals

SVS Valve Connector

• Form A
• Form B
• Form BI

Page 3.7.11



Insulation Displacement Technology

MOSA Valve Connector

• Form C
• Form CI

see onlineshop.murrelektronik.com/en



Screw Terminals

SVS Eco Valve Connector

• Form A
• Form B
• Form BI
• Form C
• Form CI

see onlineshop.murrelektronik.com/en

NOTES

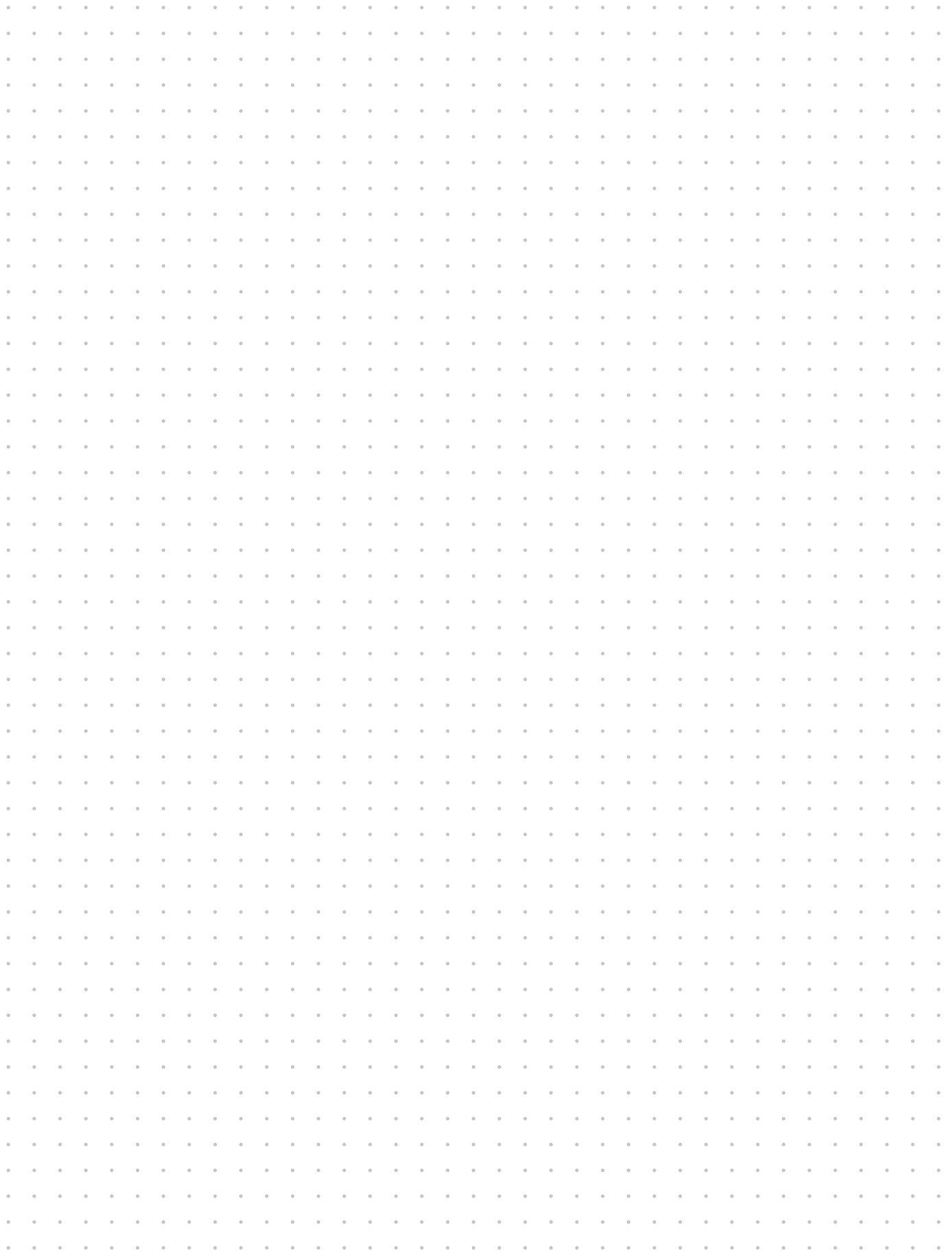

VALVE CONNECTORS

MSUD

– With open ended wires

Form A (18 mm)



Approvals:

1 Form	18001	18021	18041						
Type	24 V AC/DC LED	24 V AC/DC LED and suppression	110 V AC/DC LED and suppression						
Circuit diagram									
Contact layout									
2 Cable Type	Jacket Color								
Wire diameter 0.75 mm ²	yellow	gray	black	yellow	gray	black	yellow	gray	black
PVC	016	216	616	016	216	616	016	216	616
PUR/PVC (UL/CSA)	026	226	626	026	226	626	026	226	626
PUR (UL/CSA)	036	236	636	036	236	636	036	236	636
PUR (UL/CSA), welding spark res.	056	256	656	056	256	656	056	256	656
3 Cable Length									
1.5 m	0150								
3.0 m	0300								
5.0 m	0500								
7.5 m	0750								
10.0 m	1000								
Technical Data									
Operating voltage	24 V AC/DC ±25 %						110 V AC/DC (95...121 V AC/DC)		
Protection	IP67 inserted and tightened (EN 60529)								
Temperature range	-25...+85 °C, depending on cable quality								
Article No.									
The composition of your article number is explained on page 3.1.i	<div style="display: flex; justify-content: space-around; align-items: center;"> 7 0 0 0 - _ - _ _ _ </div>								
	1 Form			2 Cable Type			3 Cable Length		
Notes	Other versions on request. Differing cable lengths up to 2 m can be ordered in 0.2 m steps, from 2 m on in 0.5 m steps.								

VALVE CONNECTORS

MSUD

– With open ended wires

Form A (18 mm)

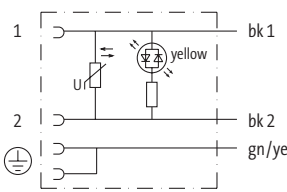
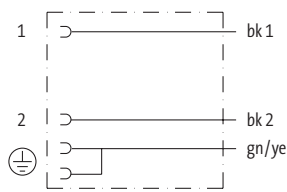
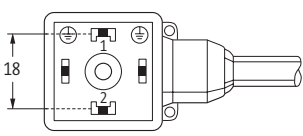

Approvals:   

1 Form	18061	18081				
Type	230 V AC/DC LED and suppression	0...230 V AC/DC without components				
Circuit diagram						
Contact layout						
2 Cable Type	Jacket Color					
Wire diameter 0.75 mm ²	yellow	gray	black	yellow	gray	black
PVC	016	216	616	016	216	616
PUR/PVC (UL/CSA)	026	226	626	026	226	626
PUR (UL/CSA)	036	236	636	036	236	636
PUR (UL/CSA), welding spark res.	056	256	656	056	256	656
3 Cable Length						
1.5 m	0150					
3.0 m	0300					
5.0 m	0500					
7.5 m	0750					
10.0 m	1000					
Technical Data						
Operating voltage	230 V AC/DC ±10 %	max. 230 V AC/DC				
Protection	IP67 inserted and tightened (EN 60529)					
Temperature range	-25...+85 °C, depending on cable quality					
Article No.						
The composition of your article number is explained on page 3.1.i	<div style="display: flex; justify-content: space-around; align-items: center;"> 7 0 0 0 - - - - - </div>					
	1 Form	2 Cable Type	3 Cable Length			
Notes	Other versions on request. Differing cable lengths up to 2 m can be ordered in 0.2 m steps, from 2 m on in 0.5 m steps.					

Valve Connectors

VALVE CONNECTORS

MSUD

- With open ended wires
- for pressure switches



Form A (18 mm)



1 Form	18121	18141				
Type	24 V DC LED (red/green)	24 V DC LED (yellow/green)				
Circuit diagram						
Contact layout						
2 Cable Type	Jacket Color					
Wire diameter 0.75 mm ²	yellow	gray	black	yellow	gray	black
PVC	018	218	618	018	218	618
PUR/PVC (UL/CSA)	028	228	628	028	228	628
PUR (UL/CSA)	038	238	638	038	238	638
3 Cable Length						
1.5 m	0150					
3.0 m	0300					
5.0 m	0500					
7.5 m	0750					
10.0 m	1000					
Technical Data						
Operating voltage	24 V DC ±25 %					
Protection	IP67 inserted and tightened (EN 60529)					
Temperature range	-25...+85 °C, depending on cable quality					
Article No.						
The composition of your article number is explained on page 3.1.i	<div style="display: flex; justify-content: space-around; align-items: center;"> 7 0 0 0 - - - - - </div>					
	1 Form	2 Cable Type	3 Cable Length			
Notes	Other versions on request. Differing cable lengths up to 2 m can be ordered in 0.2 m steps, from 2 m on in 0.5 m steps.					

VALVE CONNECTORS

MSUD

– With open ended wires

Form B (10 mm)



1 Form	10001	10021	10041						
Type	24 V AC/DC LED	24 V AC/DC LED and suppression	110 V AC/DC LED and suppression						
Circuit diagram									
Contact layout									
2 Cable Type	Jacket Color								
Wire diameter 0.75 mm ²	yellow	gray	black	yellow	gray	black	yellow	gray	black
PVC	016	216	616	016	216	616	016	216	616
PUR/PVC (UL/CSA)	026	226	626	026	226	626	026	226	626
PUR (UL/CSA)	036	236	636	036	236	636	036	236	636
PUR (UL/CSA), welding spark res.	056	256	656	056	256	656	056	256	656
3 Cable Length									
1.5 m	0150								
3.0 m	0300								
5.0 m	0500								
7.5 m	0750								
10.0 m	1000								
Technical Data									
Operating voltage	24 V AC/DC ±25 %						110 V AC/DC (95...121 V AC/DC)		
Protection	IP67 inserted and tightened (EN 60529)								
Temperature range	-25...+85 °C, depending on cable quality								
Article No.									
The composition of your article number is explained on page 3.1.i	<div style="display: flex; justify-content: space-around; align-items: center;"> 7 0 0 0 - _ - _ _ _ </div>								
	1 Form			2 Cable Type			3 Cable Length		
Notes	Other versions on request. Differing cable lengths up to 2 m can be ordered in 0.2 m steps, from 2 m on in 0.5 m steps.								

VALVE CONNECTORS

MSUD

– With open ended wires

Form B (10 mm)

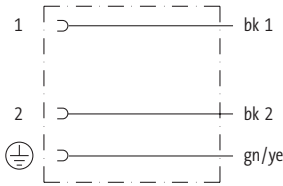
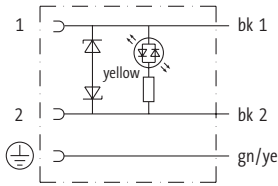
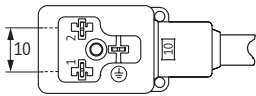
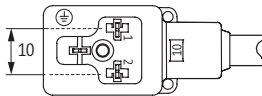

Approvals:  

1 Form	10061	10081
Type	0...230 V AC/DC without components	24 V AC/DC LED and suppression
Circuit diagram		
Contact figure	0°, PE at cable outlet	180°, PE opposite cable outlet
Contact layout		
2 Cable Type	Jacket Color	Jacket Color
Wire diameter 0.75 mm ²	yellow gray black	yellow gray black
PVC	016 216 616	016 216 616
PUR/PVC (UL/CSA)	026 226 626	026 226 626
PUR (UL/CSA)	036 236 636	036 236 636
PUR (UL/CSA), welding spark res.	056 256 656	056 256 656
3 Cable Length		
1.5 m	0150	
3.0 m	0300	
5.0 m	0500	
7.5 m	0750	
10.0 m	1000	
Technical Data		
Operating voltage	max. 230 V AC/DC	24 V AC/DC ±25 %
Protection	IP67 inserted and tightened (EN 60529)	
Temperature range	-25...+85 °C, depending on cable quality	
Article No.		
The composition of your article number is explained on page 3.1.i	<div style="display: flex; justify-content: space-around; align-items: center;"> 7 0 0 0 - - </div>	
	1 Form	2 Cable Type
		3 Cable Length
Notes	Other versions on request. Differing cable lengths up to 2 m can be ordered in 0.2 m steps, from 2 m on in 0.5 m steps.	

VALVE CONNECTORS

Junior Timer

– With open ended wires

Female
straight



Approvals:

1 Form		70001	70021
Type		0...230 V AC/DC without components	24 V AC/DC LED
Circuit diagram		<p>* for cable type (740)</p>	<p>* for cable type (740)</p>
Contact layout			
2 Cable Type		Jacket Color	Jacket Color
Wire diameter 0.5 mm ²		black	black
PUR		740	740
Wire diameter 0.75 mm ²			
PVC		752	752
PUR/PVC		750	750
3 Cable Length			
1.5 m		0150	
3.0 m		0300	
5.0 m		0500	
7.5 m		0750	
10.0 m		1000	
Technical Data			
Operating voltage		0...230 V AC/DC	24 V AC/DC
Protection		IP65 inserted and tightened	
Temperature range		-25...+85 °C, depending on cable quality	
Article No.			
The composition of your article number is explained on page 3.1.i		7 0 0 0 - - - - -	- - - - -
		1 Form	2 Cable Type 3 Cable Length
Notes			
		Other versions on request. Differing cable lengths up to 2 m can be ordered in 0.2 m steps, from 2 m on in 0.5 m steps.	

Valve Connectors

VALVE CONNECTORS

MSUD - MSUD

– Double valve plugs with connection cable

Form A (18 mm)

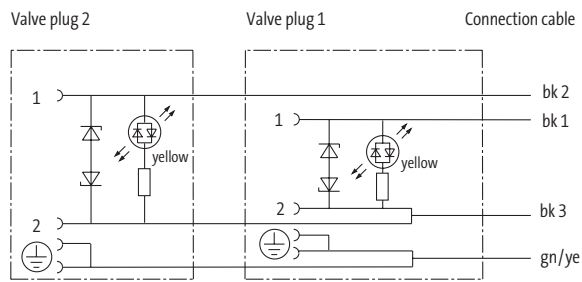
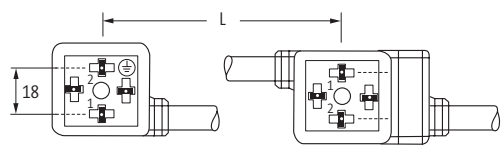

Approvals: 

1 Form	58001	58021			58041				
Type	24 V AC/DC	24 V AC/DC			24 V AC ±20 % / DC ±25 %				
LED and suppression	LED and suppression	LED and suppression			LED and suppression				
L = 100 mm	L = 150 mm	L = 150 mm			L = 200 mm				
Circuit diagram									
Contact layout									
2 Cable Type	Jacket Color			Jacket Color			Jacket Color		
Wire diameter 0.75 mm ²	yellow	gray	black	yellow	gray	black	yellow	gray	black
PVC	017	217	617	017	217	617	017	217	617
PUR/PVC	027	227	627	027	227	627	027	227	627
PUR (UL/CSA)	037	237	637	037	237	637	037	237	637
3 Cable Length									
1.5 m	0150								
3.0 m	0300								
5.0 m	0500								
7.5 m	0750								
10.0 m	1000								
Technical Data									
Operating voltage	24 V AC ±20 % / DC ±25 %								
Protection	IP67 inserted and tightened (EN 60529)								
Temperature range	-25...+85 °C, depending on cable quality								
Article No.									
The composition of your article number is explained on page 3.1.i	<div style="display: flex; justify-content: space-around; align-items: center;"> 7 0 0 0 - - </div>								
	1 Form			2 Cable Type			3 Cable Length		
Notes	Other versions on request. Differing cable lengths up to 2 m can be ordered in 0.2 m steps, from 2 m on in 0.5 m steps.								

VALVE CONNECTORS

MSUD - MSUD

– Double valve plugs with M12 male, connector at the rear

Form A (18 mm)



Approvals:

1 Form	41561	41581	41601						
Type	24 V AC/DC, M12 (4-pole)	24 V AC/DC, M12 (4-pole)	24 V AC/DC, M12 (4-pole)						
LED and suppression	LED and suppression	LED and suppression	LED and suppression						
L = 100 mm	L = 100 mm	L = 150 mm	L = 200 mm						
Circuit diagram									
Contact layout									
2 Cable Type	Jacket Color		Jacket Color		Jacket Color				
Wire diameter 0.75 mm ²	yellow	gray	black	yellow	gray	black	yellow	gray	black
PVC	016	216	616	016	216	616	016	216	616
PUR/PVC (UL/CSA)	026	226	626	026	226	626	026	226	626
PUR (UL/CSA)	036	236	636	036	236	636	036	236	636
Technical Data									
Operating voltage	24 V AC ±20 % / DC ±25 %								
Protection	IP67 inserted and tightened (EN 60529)								
Temperature range	-25...+85 °C, depending on cable quality								
Article No.									
The composition of your article number is explained on page 3.1.i	<u>7 0 0 0</u>		-	-		-	<u>0 0 0 0</u>		
	1 Form			2 Cable Type					
Notes	Other versions on request.								

Valve Connectors

VALVE CONNECTORS

MSUD - M12

– Connection cables



Form A (18 mm)

Male M12

straight

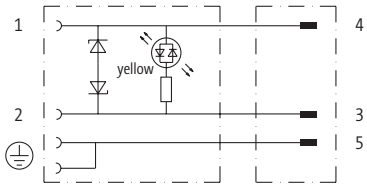
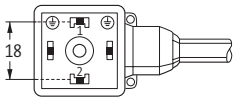

Approvals: 

1 Form		40881		
Type	24 V AC/DC, M12 (3-pole) LED and suppression			
Circuit diagram				
Contact layout	<div style="display: flex; justify-content: space-around;"> <div style="text-align: center;"> <p>Female</p>  </div> <div style="text-align: center;"> <p>Male</p>  </div> </div>			
2 Cable Type		Jacket Color		
Wire diameter 0.75 mm ²	yellow	gray	black	
PVC	016	216	616	
PUR/PVC (UL/CSA)	026	226	626	
PUR (UL/CSA)	036	236	636	
PUR (UL/CSA), welding spark res.	056	256	656	
3 Cable Length				
0.3 m	0030			
0.6 m	0060			
1.0 m	0100			
1.5 m	0150			
2.0 m	0200			
Technical Data				
Operating voltage	24 V AC ±20 % / DC ±25 %			
Protection	IP67 inserted and tightened (EN 60529)			
Temperature range	-25...+85 °C, depending on cable quality			
Article No.				
The composition of your article number is explained on page 3.1.i		7 0 0 0	-	4 0 8 8 1
		-	-	
		1	2	3
		Form Cable Type		Cable Length
Notes		Other versions on request. Differing cable lengths up to 2 m can be ordered in 0.2 m steps, from 2 m on in 0.5 m steps.		

VALVE CONNECTORS

MSUD - M12

- Connection cables
- for pressure switches



Form A (18 mm)

Male M12
straight



1 Form	40921	40931	
	24 V DC, M12 (5-pole) LED (red/green)	24 V DC, M12 (5-pole) LED (yellow/green)	
Circuit diagram			
Contact layout	<p>Female</p>	<p>Male</p>	
2 Cable Type	Jacket Color	Jacket Color	
	Wire diameter 0.34 mm ²	yellow gray black	yellow gray black
	PVC (UL/CSA)	015 215 615	015 215 615
	PUR/PVC (UL/CSA)	025 225 625	025 225 625
	PUR (UL/CSA)	035 (126) 235 635 (732)	035 (126) 235 635 (732)
PUR (UL/CSA), welding spark res.	055 255 655	055 255 655	
3 Cable Length	0.3 m	0030	
	0.6 m	0060	
	1.0 m	0100	
	1.5 m	0150	
	2.0 m	0200	
Technical Data	<p>Operating voltage: 24 V DC ±25 %</p> <p>Protection: IP67 inserted and tightened (EN 60529)</p> <p>Temperature range: -25...+85 °C, depending on cable quality</p>		
Article No.	<p>The composition of your article number is explained on page 3.1.i</p> <p><u>7 0 0 0</u> - - - - -</p>		
	1 Form	2 Cable Type	
		3 Cable Length	
Notes	Other versions on request. Differing cable lengths up to 2 m can be ordered in 0.2 m steps, from 2 m on in 0.5 m steps.		

Valve Connectors

VALVE CONNECTORS

SVS

- Field-wireable
- Convenient connection, screw terminals

Approvals: 

Form A (18 mm)



1 Form	29001	29021	29041	29061
Type	24 V AC/DC	24 V AC/DC	24 V AC/DC	24 V AC/DC
	LED and Z-diode	LED and Z-diode	LED and RC	LED and RC
	metric	PG 9	metric	PG 9
Circuit diagram				
Contact layout				
Technical Data				
Operating voltage	24 V AC ±20 % / DC ±25 %		24 V AC/DC ±25 %	
Operating current per contact	max. 4 A		max. 2 A	
Switch off peak	max. 55 V		-	
Max. power (W)	max. 100 W(VA)		max. 50 W(VA)	
Connection cross section	4 mm ² single core, with ferrule end 1.5 mm ²		-	
Sealing range (cable diameter)	5...10 mm	6...8 mm	5...10 mm	4 mm ² single core, with ferrule end 1.5 mm ² 6...8 mm
Locking of ports	M3 (recommended torque 0.4 Nm)			
Compression gland	M16 × 1.5 mm	PG 9; (PG11, NPT 1/2" o. r.)	M16 × 1.5 mm	PG 9; (PG11, NPT 1/2" o. r.)
Protection	IP65 inserted and tightened (EN 60529), with gland			
Temperature range	-20...+60 °C			
Article No.				
The composition of your article number is explained on page 3.1.i	<u>7</u> <u>0</u> <u>0</u> <u>0</u>	-	<u>0</u> <u>0</u> <u>0</u>	<u>0</u> <u>0</u> <u>0</u> <u>0</u>
	1 Form			
Notes	Other versions on request.			

VALVE CONNECTORS

SVS

- Field-wireable
- Convenient connection, screw terminals

Approvals: 

Form A (18 mm)

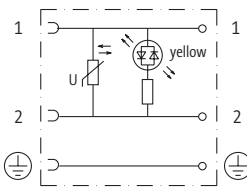
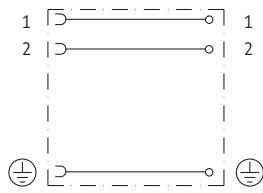
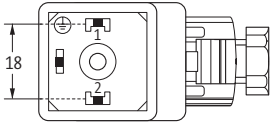

1 Form	29081	29101	29241	29261
Type	110 V AC/DC	110 V AC/DC	0...230 V AC/DC	0...230 V AC/DC
LED and VDR	LED and VDR	LED and VDR	without components	without components
	metric	PG 9	metric	PG 9
Circuit diagram				
Contact layout				
Technical Data				
Operating voltage	110 V AC/DC (95...121 V AC/DC)		0...230 V AC/DC	
Operating current per contact	max. 4 A		max. 10 A	
Switch off peak	max. 250 V		-	
Max. power (W)	max. 100 W(VA)		-	
Connection cross section	4 mm ² single core, with ferrule end 1.5 mm ²			
Sealing range (cable diameter)	5...10 mm	6...8 mm	5...10 mm	6...8 mm
Locking of ports	M3 (recommended torque 0.4 Nm)			
Compression gland	M16 × 1.5 mm	PG 9; (PG11, NPT 1/2" o. r.)	M16 × 1.5 mm	PG 9; (PG11, NPT 1/2" o. r.)
Protection	IP65 inserted and tightened (EN 60529), with gland			
Temperature range	-20...+60 °C			
Article No.				
The composition of your article number is explained on page 3.1.i	<u>7</u> <u>0</u> <u>0</u> <u>0</u>	-	-	<u>0</u> <u>0</u> <u>0</u> <u>0</u>
	1 Form			
Notes	Other versions on request.			

VALVE CONNECTORS

SVS

- Field-wireable
- Convenient connection, screw terminals

Approvals: 

Form A (18 mm)

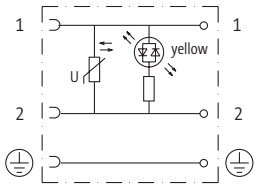
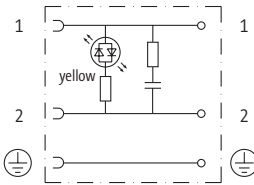
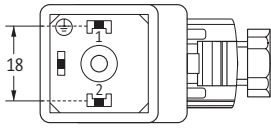

1 Form	29161	29181	29121	29141
Type	230 V AC/DC	230 V AC/DC	110 V AC/DC and 230 V AC/DC	110 V AC/DC and 230 V AC/DC
	LED and VDR	LED and VDR	LED and RC	LED and RC
	metric	PG 9	metric	PG 9
Circuit diagram				
Contact layout				
Technical Data				
Operating voltage	230 V AC/DC ±10 %		110 V AC/DC ±10 % and 230 V AC/DC ±10 %	
Operating current per contact	max. 1 A			
Switch off peak	max. 533 V		-	
Max. power (W)	max. 100 W(VA)		max. 50 W(VA)	
Connection cross section	4 mm ² single core, with ferrule end 1.5 mm ²			
Sealing range (cable diameter)	5...10 mm	6...8 mm	5...10 mm	6...8 mm
Locking of ports	M3 (recommended torque 0.4 Nm)			
Compression gland	M16 × 1.5 mm	PG 9; (PG11, NPT 1/2" o. r.)	M16 × 1.5 mm	PG 9; (PG11, NPT 1/2" o. r.)
Protection	IP65 inserted and tightened (EN 60529), with gland			
Temperature range	-20...+60 °C			
Article No.				
The composition of your article number is explained on page 3.1.i	<div style="display: flex; justify-content: space-around; align-items: center;"> <u>7</u> <u>0</u> <u>0</u> <u>0</u> - _____ - <u>0</u> <u>0</u> <u>0</u> _____ <u>0</u> <u>0</u> <u>0</u> <u>0</u> </div>			
	1 Form			
Notes	Other versions on request.			

VALVE CONNECTORS

SVS

- Field-wireable
- Convenient connection, screw terminals
- for pressure switches

Approvals: 

Form A (18 mm)

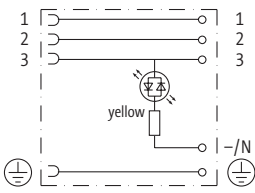
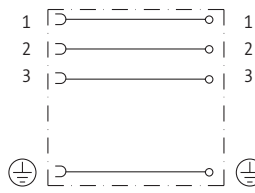
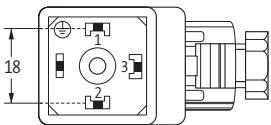

1 Form	29361	29381	29401	29421
Type	24...230 V AC/DC	24...230 V AC/DC	0...230 V AC/DC	0...230 V AC/DC
	LED yellow (3)	LED yellow (3)	without components	without components
	metric	PG 9	metric	PG 9
Circuit diagram				
Contact layout				
Technical Data				
Operating voltage	24...230 V AC/DC		0...230 V AC/DC	
Operating current per contact	max. 4 A		max. 10 A	
Sealing range (cable diameter)	5...10 mm	6...8 mm	5...10 mm	6...8 mm
Locking of ports	M3 (recommended torque 0.4 Nm)			
Compression gland	M16 × 1.5 mm	PG 9; (PG11, NPT 1/2" o. r.)	M16 × 1.5 mm	PG 9; (PG11, NPT 1/2" o. r.)
Protection	IP65 inserted and tightened (EN 60529), with gland			
Temperature range	-20...+60 °C			
Article No.				
The composition of your article number is explained on page 3.1.i	<u>7</u> <u>0</u> <u>0</u> <u>0</u>	-	-	<u>0</u> <u>0</u> <u>0</u> <u>0</u>
	1 Form			
Notes	Other versions on request.			



CUBE67 MODULAR I/O STATION IP67

- Open System
- Modular
- Flexible

CHANGE THE BUS WITHOUT CHANGING THE SYSTEM

Cube67 brings you balanced and cost-effective solutions. Murrelektronik's innovative fieldbus system has simplified and modernized decentralized installations from the ground up. The machine installation is independent from the control and the fieldbus, which makes it possible to customize the control without having to modify the I/O peripherals.



Cube67 I/O Modules

 <p>Bus Nodes • IP67 protection</p> <p style="text-align: right;"><i>Page 4.1.1</i></p>	 <p>Digital Inputs • IP67 protection</p> <p style="text-align: right;"><i>Page 4.1.3</i></p>
 <p>Multifunctional Inputs/Outputs • IP67 protection</p> <p style="text-align: right;"><i>Page 4.1.14</i></p>	 <p>Digital Inputs and Outputs with Cable • IP67 protection</p> <p style="text-align: right;"><i>Page 4.1.10</i></p>
 <p>Safe outputs • IP67 protection</p> <p style="text-align: right;"><i>see onlineshop.murrelektronik.com/en</i></p>	 <p>Function Modules • IP67 protection</p> <p style="text-align: right;"><i>Page 4.1.8</i></p>
 <p>Analog Inputs • IP67 protection</p> <p style="text-align: right;"><i>Page 4.1.11</i></p>	 <p>Analog Outputs • IP67 protection</p> <p style="text-align: right;"><i>Page 4.1.13</i></p>

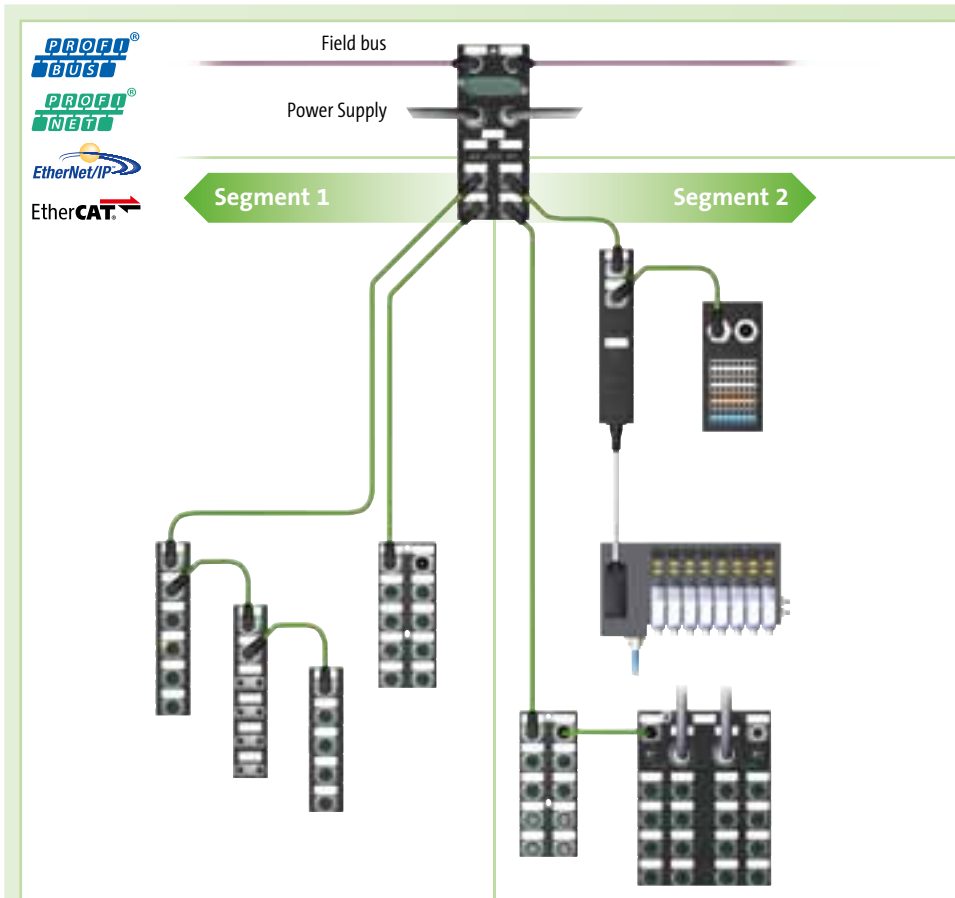

cube67⁺

- 2 segments
- Per segment:
 - 16 modules
 - 30 meters cable length
- Pin Level Diagnostics
- LED Indicator per I/O
- Topology
 - Star/line
- Transfer type
 - Change of State
- System connection
 - Hybrid cable M12
- Addressing
 - Automatically

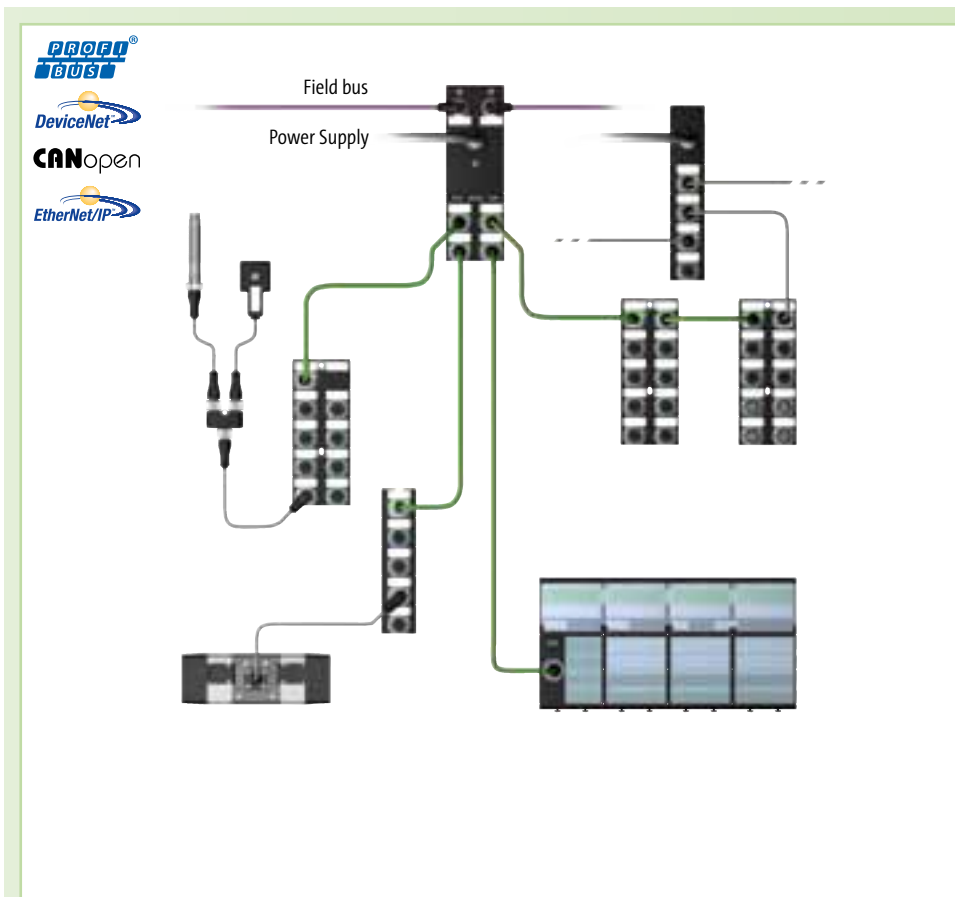

cube67

- 4 lines
- Per line:
 - 4 modules
 - 10 meters cable length
- Pin Level Diagnostics
- LED Indicator per I/O
- Topology
 - Star/line
- Transfer type
 - Change of State
- System connection
 - Hybrid cable M12
- Addressing
 - Automatically

CONSISTENT DIAGNOSTICS WITH cube67⁺

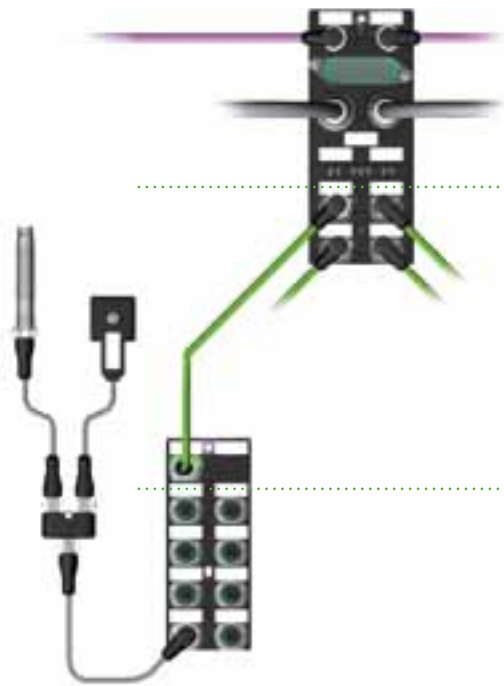

BUS NODES

- Communication
- Under voltage
- Module status
- Overload

I/O MODULE

- Communication
- Under voltage
- Overload

PORT

- Signal status
- Overflow and underflow (measured value)
- Short circuit
- Overload
- Cable break
- Actuator warning

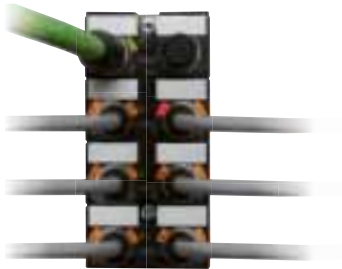

DON'T LOOK FOR ERRORS, FIND THEM: COMPREHENSIVE DIAGNOSTICS

- Only the affected channel switches off
- Minimizes downtime
- Enables remote maintenance

HIGHLY FLEXIBLE WITH MULTIFUNCTIONAL I/Os

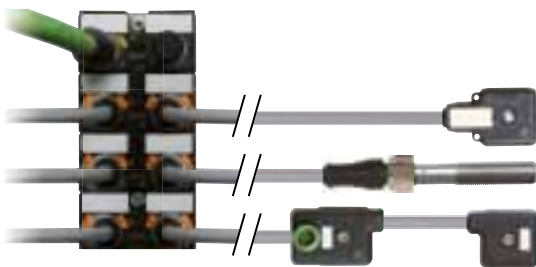

- Two signals per port, either input, diagnostics input or output, can all be independently configured
- Avoid unused reserves
- Double valves require only one port

Cube67 and Cube67+ are the new benchmark in automation. Small, multifunctional I/O modules and a variety of different interfaces are the keys to simplified installations. They can be installed close to sensors and loads. This saves installation time and offers benefits during service with easy trouble-shooting.

CUBE67

Bus Nodes, Cube67+

– up to 32 modules

– max. 2x30 m system expansion



EtherNet/IP
conformance tested



Cube67+ BN-P



Cube67+ BN-PNIO



Cube67+ BN-E

Order Data	Art-No.	Art-No.	Art-No.
PROFIBUS DP	56521		
PROFINET IO		56526	
EtherNet-IP			56525
Connections			
Fieldbus	M12, B-coded	M12, A-coded, 5-pole	M12, D-coded
Sensor-system/actuator supply	7/8", 5-pole, 2 x max. 8 A		
Internal system connection	via M12, 6 pole; max. 4 A		
Fieldbus			
Operating modes	Sync- and freeze mode are supported	Autonegotiation/Auto MDI/MDI-X	
Transfer rate	to 12 Mbit/s	to 100 Mbit/s Full Duplex	
Addressing	Rotary switch 0..99	DHCP, BOOTP or IP address by rotary switch	
Module Supply			
Operating voltage	24 V DC (EN 61131-2)		
Current consumption	max. 120 mA	max. 200 mA	
Diagnostic			
Communication status	per LED and BUS		
Diagnostic via LED	per module and channel		
Diagnostic via BUS	per module and channel		
Monitoring - under voltage	yes		
Monitoring - no voltage	yes		
Short circuit and overload	yes		
General data			
Protection	IP67		
Mounting method	2-hole screw mounting		
Temperature range	0...+55 °C (storage temperature -20...+75 °C)		
Dimension drawing			

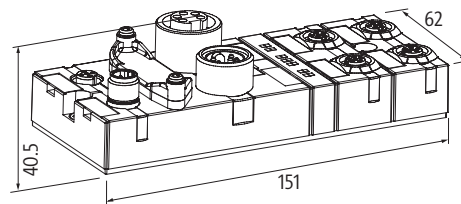

Notes
Cube67+ modules can only be operated on Cube67+, Profibus + ProfiNet bus nodes.

CUBE67

Bus Nodes, Cube67

- up to 16 modules
- max. 4x10m system expansion

EtherNet/IP
performance tested

DeviceNet
CONFORMANCE TESTED

CANopen

Approvals:  

Cube67 BN-E



Cube67 BN-DN



Cube67 BN-C

Order Data	Art-No.	Art-No.	Art-No.
EtherNet-IP	56505		
DeviceNet		56507	
CANopen			56504
Connections			
Fieldbus	M12, D-coded	M12, A-coded	
Sensor-system/actuator supply	via 7/8" power; max. 9 A		
Internal system connection	via M12, 6 pole; max. 4 A		
Fieldbus			
Operating modes	Autonegotiation/Auto MDI/MDI-X	Polling; change of state; Cyclic	
Transfer rate	to 100 Mbit/s	125, 250, 500 kbit/s	10, 20, 50, 125, 250, 500, 800, 1000 kbit/s
Addressing	DHCP, BOOTP or IP address by rotary switch	Rotary switch 0...63	Rotary switch 1...99
Module Supply			
Operating voltage	24 V DC (EN 61131-2)		
Current consumption	max. 70 mA	approx. 70 mA	
Diagnostic			
Communication status	per LED and BUS		
Diagnostic via LED	per module and channel		
Diagnostic via BUS	per module and channel		
Monitoring - under voltage	yes		
Monitoring - no voltage	yes		
Short circuit and overload	yes		
General data			
Protection	IP67		
Mounting method	2-hole screw mounting		
Temperature range	0...+55 °C (storage temperature -20...+75 °C)		
Dimension drawing			

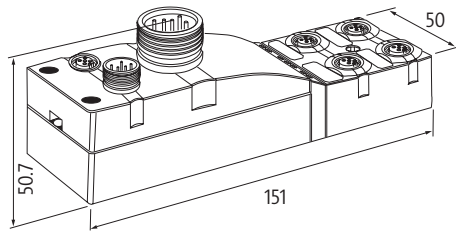

Notes

CUBE67

Compact module

– Digital inputs

Cube67 DI16 C - 8×M12

Cube67 DI8 C - 4×M12

Cube67 DI8 C - 8×M8

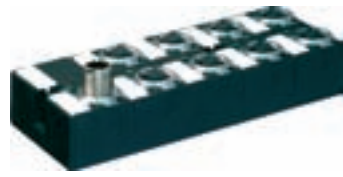

Approvals:

Order Data	Art-No.	Art-No.	Art-No.
DI16 - (C) 8×M12	56602		
DI8 - (C) 4×M12		56612	
DI8 - (C) 8×M8			56622
Internal communication			
Current consumption	max. 50 mA		max. 30 mA
LED display	US: sensor supply and internal supply voltage (green: OK); UA: actuator supply (green: OK)		
Terminating resistor	integrated into the module		
Connections			
Fieldbus	via internal system connection		
Sensor-system/actuator supply	via internal system connection (max. 2×4 A)		
I/O ports	M12 (male) 5-pole, A-coded		
Input			
Sensor supply US	24 V DC (EN 61131-2), max. 200 mA (M12 female), short-circuit and overload protected		24 V DC (EN 61131-2), max. 200 mA (M8 female), short-circuit and overload protected
Type	for 3-wire sensors or mechanical switches, p-switching (EN 61131-2)		
Input filter	1 ms		
Parameterization			
PIN 2	Input/diagnostic	–	
PIN 4	Input		
Diagnostic			
Communication status	via LED		
Diagnostic via LED	per module and channel		
Diagnostic via BUS	per module and channel		
Monitoring - under voltage	yes		
Monitoring - no voltage	yes		
Short circuit and overload	yes		
General data			
Protection	IP67		
Mounting method	2-hole screw mounting		
Temperature range	0...+55 °C (storage temperature -20...+75 °C)		
Dimension drawing			
Notes			

CUBE67

Expansion module

- Digital inputs



Cube67 DI16 E - 8xM12



Cube67 DI8 E - 4xM12



Cube67 DI8 E - 8xM8



Order Data	Art-No.	Art-No.	Art-No.
DI16 - (E) p-switching (8xM12)	56603		
DI16 - (E) n-switching (8xM12)	56606		
DI8 - (E) p-switching (4xM12)		56613	
DI8 - (E) n-switching (4xM12)		56616	
DI8 - (E) p-switching (8xM8)			56623
DI8 - (E) n-switching (8xM8)			56626
Internal communication			
Current consumption	max. 50 mA		max. 30 mA
LED display	US: sensor supply and internal supply voltage (green: OK); UA: actuator supply (green: OK)		
Connections			
Fieldbus	via internal system connection		
Sensor-system/actuator supply	via internal system connection (max. 2x4 A)		
I/O ports	M12 (male) 5-pole, A-coded		
Input			
Sensor supply US	24 V DC (EN 61131-2), max. 200 mA (M12 female), short-circuit and overload protected		24 V DC (EN 61131-2), max. 200 mA (M8 female), short-circuit and overload protected
Type	for 3-wire sensors or mechanical switches (EN 61131-2)		
Input filter	1 ms		
Parameterization			
PIN 2	Input/diagnostic		-
PIN 4	Input		
Diagnostic			
Communication status	via LED		
Diagnostic via LED	per module and channel		
Diagnostic via BUS	per module and channel		
Monitoring - under voltage	yes		
Monitoring - no voltage	yes		
Short circuit and overload	yes		
General data			
Protection	IP67		
Mounting method	2-hole screw mounting		
Temperature range	0...+55 °C (storage temperature -20...+75 °C)		
Dimension drawing			

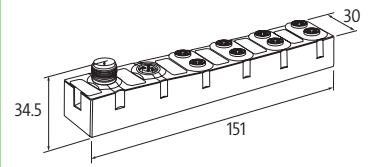
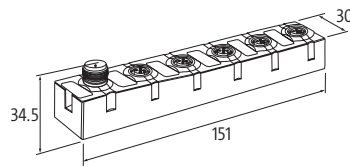
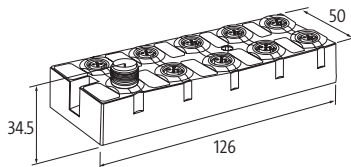

Notes

CUBE67

Compact module

– Multifunctional I/Os

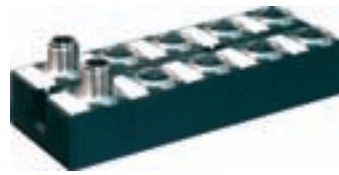
Cube67 DIO16 C - 8×M12

Cube67 DIO8 C - 4×M12

Cube67 DIO8 C - 8×M12

Cube67

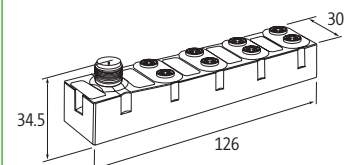
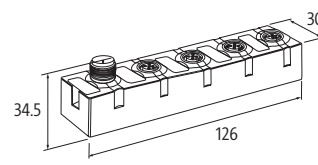
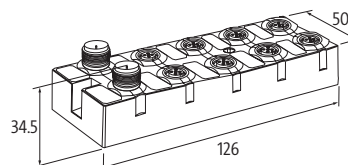
Order Data	Art-No.	Art-No.	Art-No.
DIO16 - 0.5 A (C) 8×M12	56600		
DIO16 - 1.6 A (C) 8×M12	56640		
DIO8 - 0.5 A (C) 4×M12		56610	
DIO8 - 0.5 A (C) 8×M8			56620
Internal communication			
Current consumption	max. 50 mA		max. 30 mA
LED display	US: sensor supply and internal supply voltage (green: OK); UA: actuator supply (green: OK)		
Terminating resistor	integrated into the module		
Connections			
Fieldbus	via internal system connection		
Sensor-system/actuator supply	via internal system connection (max. 2×4 A)		
I/O ports	M12 (male) 5-pole, A-coded		
Input			
Sensor supply US	24 V DC (EN 61131-2), max. 200 mA (M12 female), short-circuit and overload protected		24 V DC (EN 61131-2), max. 200 mA (M8 female), short-circuit and overload protected
Type	for 3-wire sensors or mechanical switches, p-switching (EN 61131-2)		
Input filter	1 ms		
Parameterization			
PIN 2	Input/output/diagnostic		–
PIN 4	Input/output		
Output			
Actuator supply UA	24 V DC (EN 61131-2), via system connection (max. 4 A) + right actuators via supply right (max. 4 A)		24 V DC (EN 61131-2), via system connection (max. 4 A)
Lamp load	10 W		
Diagnostic			
Communication status	via LED		
Diagnostic via LED	per module and channel		
Diagnostic via BUS	per module and channel		
Monitoring - under voltage	yes		
Monitoring - no voltage	yes		
Short circuit and overload	yes		
Actuator warning	per channel via LED and BUS		
General data			
Protection	IP67		
Mounting method	2-hole screw mounting		
Temperature range	0...+55 °C (storage temperature -20...+75 °C)		
Dimension drawing			

Notes

CUBE67

Expansion module

– Multifunctional I/Os



Cube67 DIO16 E - 8×M12



Cube67 DIO8 E - 4×M12



Cube67 DIO8 E - 8×M8



Order Data	Art-No.	Art-No.	Art-No.
DIO16 - 0.5 A (E) 8×M12	10 W 56601		
DIO8 - 0.5 A (E) 4×M12		10 W 56611	
DIO8 - 1.0 A (E) 4×M12		20 W 56631	
DIO8 - 0.5 A (E) 8×M8			10 W 56621
Internal communication			
Current consumption	max. 50 mA		max. 30 mA
LED display	US: sensor supply and internal supply voltage (green: OK); UA: actuator supply (green: OK)		
Connections			
Fieldbus	via internal system connection		
Sensor-system/actuator supply	via internal system connection (max. 2×4 A)		
I/O ports	M12 (male) 5-pole, A-coded		
Input			
Sensor supply US	24 V DC (EN 61131-2), max. 200 mA (M12 female), short-circuit and overload protected		24 V DC (EN 61131-2), max. 200 mA (M8 female), short-circuit and overload protected
Type	for 3-wire sensors or mechanical switches, p-switching (EN 61131-2)		
Input filter	1 ms		
Parameterization			
PIN 2	Input/output/diagnostic		–
PIN 4	Input/output		
Output			
Actuator supply UA	24 V DC (EN 61131-2), via system connection (max. 4 A)		
Diagnostic			
Communication status	via LED		
Diagnostic via LED	per module and channel		
Diagnostic via BUS	per module and channel		
Monitoring - under voltage	yes		
Monitoring - no voltage	yes		
Short circuit and overload	yes		
Actuator warning	per channel via LED and BUS		
General data			
Protection	IP67		
Mounting method	2-hole screw mounting		
Temperature range	0...+55 °C (storage temperature -20...+75 °C)		
Dimension drawing			

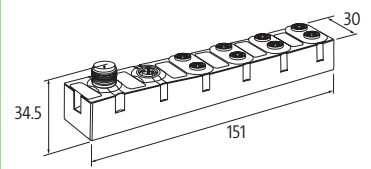
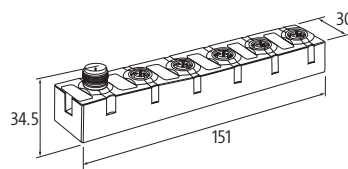
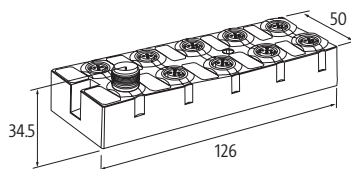

Notes

CUBE67

Terminal modules

– Multifunctional I/Os

– Digital inputs

Cube67 DIO8/DI8 E (TB-Box)



Cube67 DIO8/DI8 E (TB-Box)

with additional potential terminals

Cube67 DIO8/DI8 E (TB-Rail)



Order Data	Art-No.	Art-No.	Art-No.
DIO8/DI8 - (E) TB-Box	GOST	56681	5668100
DIO8/DI8 - (E) TB-Rail			cULus, GOST
Internal communication			
Current consumption	max. 50 mA		
LED display	US: sensor supply and internal supply voltage (green: OK); UA: actuator supply (green: OK)		
Connections			
Fieldbus	via internal system connection		
Sensor-system/actuator supply	via internal system connection (max. 2x4 A)		
I/O ports	M12 (male) 5-pole, A-coded		
Input			
Sensor supply US	24 V DC (EN 61131-2), max. 8 × 200 mA		
Type	for 3-wire sensors or mechanical switches, p-switching (EN 61131-2)		
Input filter	1 ms		
Parameterization			
Terminal row X 0 (8 channels)	Input		
Terminal row X 1 (8 channels)	Input/output		
Output			
Actuator supply UA	24 V DC (EN 61131-2), via system connection (max. 4 A)		
Switching current per output	max. 0.5 A (short-circuit and overload protected)		
Lamp load	10 W		
Diagnostic			
Communication status	via LED		
Diagnostic via LED	per module and channel		
Diagnostic via BUS	per module and channel		
Monitoring - under voltage	yes		
Monitoring - no voltage	yes		
Short circuit and overload	yes		
Actuator warning	per channel via LED and BUS		
General data			
Protection	IP66		IP20
Mounting method	screw fixing		DIN-rail mountable (EN 60715)
Temperature range	0...+55 °C (storage temperature -20...+75 °C)		
Dimension drawing			
Notes			

CUBE67

Function modules

Cube67 CNT2 - C 4×M12

Counter module with preprocessing



Cube67 Logic - DI6 DO2 E 4×M12

Logic module



Approvals:  

Order Data	Art-No.	Art-No.
Compact module	56750	
Expansion module		56771
Internal communication		
Current consumption	max. 50 mA	
LED display	US: sensor supply and internal supply voltage (green: OK); UA: actuator supply (green: OK)	
Connections		
Fieldbus	via internal system connection	
Sensor-system/actuator supply	via internal system connection (max. 2×4 A)	
I/O ports	M12 (male) 5-pole, A-coded	
Input		
Sensor supply US	24 V DC (EN 61131-2), max. 200 mA (M12 female), short-circuit and overload protected	
Type	for 3-wire sensors or mechanical switches, p-switching (EN 61131-2)	
Input filter	1 ms	
Logic module		
Inputs	–	6
Outputs	–	2
Logic function	–	AND, NOR; AND; XOR parameters definable
Counter		
Counter frequency	max. 300 kHz	–
Counter input	(EN 61131-2)	–
Counter depth	32 Bit (31 Bit + sign)	–
Output		
Actuator supply UA	24 V DC (EN 61131-2), via system connection (max. 4 A)	
Switching current per output	max. 1.6 A (short-circuit and overload protected)	max. 0.5 A (short-circuit and overload protected)
Lamp load	30 W	10 W
Diagnostic		
Communication status	via LED	
Diagnostic via LED	per module and channel	
Diagnostic via BUS	per module and channel	
Monitoring - under voltage	yes	
Monitoring - no voltage	yes	
Short circuit and overload	yes	
Actuator warning	per channel via LED and BUS	
General data		
Protection	IP67	
Mounting method	2-hole screw mounting	
Temperature range	0...+55 °C (storage temperature -20...+75 °C)	
Dimension drawing		

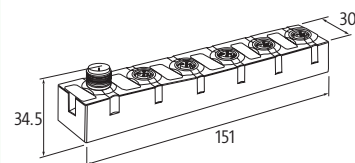
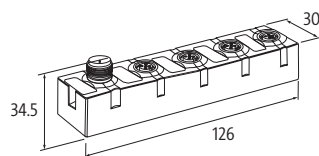

Notes

Function modules

– Multifunctional I/Os

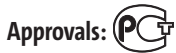

Cube67+ DIO4 RS232/485 - E 4xM12

Serial interface



Cube67 DIO4 RS485 - E 3xM12

Serial interface



Order Data	Art-No.	Art-No.
DIO4 - RS232/485 (E) 4xM12	56761	
DIO4 - RS485 (E) 3xM12		cUlus 56760
Internal communication		
Current consumption	max. 80 mA	max. 50 mA
LED display	US: sensor supply and internal supply voltage (green: OK); UA: actuator supply (green: OK)	
Connections		
Fieldbus	via internal system connection	
Sensor-system/actuator supply	via internal system connection (max. 2x4 A)	
I/O ports	M12 (male) 5-pole, A-coded	
Technical Data		
Transfer parameters	RS232: 230.4 kBaud, full duplex; RS485: 230.4 kBaud, half duplex	9600 Baud, half duplex
RS232-Type	galvanically separated, M12 female 5-pole, B-coded	–
RS485-Type	galvanically separated, M12 female 5-pole, B-coded	
Input		
Sensor supply US	24 V DC (EN 61131-2), max. 200 mA (M12 female), short-circuit and overload protected	
Type	for 3-wire sensors or mechanical switches, p-switching (EN 61131-2)	
Input filter	1 ms	
Parameterization		
PIN 2	Input/output/diagnostic	
PIN 4	Input/output	
Output		
Actuator supply UA	24 V DC (EN 61131-2), via system connection (max. 4 A)	
Switching current per output	max. 0.5 A (short-circuit and overload protected)	
Lamp load	10 W	
Diagnostic		
Communication status	via LED	
Diagnostic via LED	per module and channel	
Diagnostic via BUS	per module and channel	
Monitoring - under voltage	yes	
Monitoring - no voltage	yes	
Short circuit and overload	yes	
Actuator warning	per channel via LED and BUS	
General data		
Protection	IP67	
Mounting method	2-hole screw mounting	
Temperature range	0...+55 °C (storage temperature -20...+75 °C)	

Dimension drawing

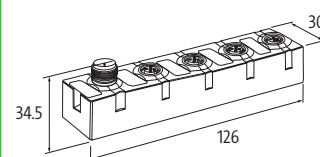
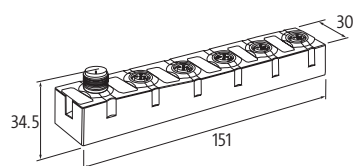

Notes
Cube67+ modules can only be operated on Cube67+, Profibus + ProfiNet bus nodes.

CUBE67

Analog inputs

– Voltage/current

Approvals: 

Cube67 AI4 C - 4×M12

Compact module
Voltage



Cube67 AI4 C - 4×M12

Compact module
Current

Cube67 AI4 E - 4×M12

Expansion module
Voltage



Cube67 AI4 E - 4×M12

Expansion module
Current

Order Data	Art-No.	Art-No.	Art-No.	Art-No.
AI4 - (C) 4×M12 (U)	cULus	56700		
AI4 - (C) 4×M12 (I)		cULus	56730	
AI4 - (E) 4×M12 (U)			cULus	56701
AI4 - (E) 4×M12 (I)				56731

Internal communication

Current consumption	max. 50 mA			
LED display	US: sensor supply and internal supply voltage (green: OK); UA: actuator supply (green: OK)			

Connections

Fieldbus	via internal system connection			
Sensor-system/actuator supply	via internal system connection (max. 2×4 A)			
I/O ports	M12 (male) 5-pole, A-coded			

Input

Conversion time (analog)	approx. 2 ms (per channel)			
Sensor supply US	24 V DC (EN 61131-2), max. 200 mA (M12 female), short-circuit and overload protected			
Resolution (analog)	15 Bit + sign	15 Bit	15 Bit + sign	15 Bit
Accuracy	max. ±0.5 % (of range limit)			

Voltage inputs

Input resistor	approx. 1 MOhm, differential input	–	approx. 1 MOhm, differential input	–
Input range	±10 V DC, 0...10 V DC	–	±10 V DC, 0...10 V DC	–

Current input signals

Load	–	approx. 300 Ohm, differential input	–	approx. 300 Ohm, differential input
Input range	–	0...20 mA, 4...20 mA	–	0...20 mA, 4...20 mA

Diagnostic

Communication status	via LED			
Diagnostic via LED	per module and channel			
Diagnostic via BUS	per module and channel			
Monitoring - under voltage	yes			
Monitoring - no voltage	yes			
Short circuit and overload	yes			
Actuator warning	per channel via LED and BUS			
Wire break upper/lower limit overload	per channel via LED and BUS			

General data

Protection	IP67			
Mounting method	2-hole screw mounting			
Temperature range	0...+55 °C (storage temperature -20...+75 °C)			

Dimension drawing

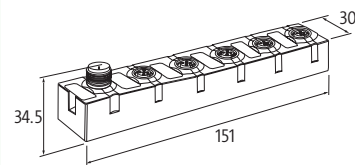
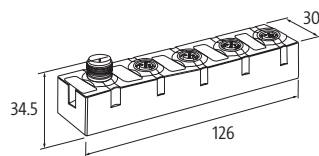

Notes

CUBE67

Analog inputs

– for resistors and temperature

– for thermo elements

Approvals:

Cube67 AI4 C (RTD) - 4×M12

Compact module
for resistors and temperature



Cube67 AI4 E (RTD) - 4×M12

Expansion module
for resistors and temperature



Order Data	Art-No.	Art-No.
AI4 - (C) 4×M12 (RTD)	cULus	56740
AI4 - (E) 4×M12 (RTD)		56741
Internal communication		
Current consumption	max. 50 mA	
LED display	US: sensor supply and internal supply voltage (green: OK); UA: actuator supply (green: OK)	
Connections		
Fieldbus	via internal system connection	
Sensor-system/actuator supply	via internal system connection (max. 2×4 A)	
I/O ports	M12 (male) 5-pole, A-coded	
Input		
Sensor type	Pt 100, 200, 500, 1000; Ni 100, 120, 200, 500, 1000; R 0...3000 Ohm	
Conversion time (analog)	approx. 58 ms per channel	
Resolution (analog)	15 Bit + sign	
Accuracy	max. ±0.5 % (of range limit)	
Accuracy (Ni)	max. ±1 % (of range limit)	
Connection	2-, 3-, 4-wire technology	
Diagnostic		
Communication status	via LED	
Diagnostic via LED	per module and channel	
Diagnostic via BUS	per module and channel	
Monitoring - under voltage	yes	
Monitoring - no voltage	yes	
Short circuit and overload	yes	
Actuator warning	per channel via LED and BUS	
Wire break upper/lower limit overload	per channel via LED and BUS	
General data		
Protection	IP67	
Mounting method	2-hole screw mounting	
Temperature range	0...+55 °C (storage temperature -20...+75 °C)	
Dimension drawing		
Notes		

CUBE67

Analog inputs

– for resistors and temperature

– for thermo elements

Approvals: 

Cube67 AI4 C (TH) - 4×M12

Compact module
for thermo elements



Cube67 AI4 E (TH) - 4×M12

Expansion module
for thermo elements



Order Data	Art-No.	Art-No.
AI4 - (C) 4×M12 (TH)	cUlus	56748
AI4 - (E) 4×M12 (TH)		56749
Internal communication		
Current consumption	max. 50 mA	
LED display	US: sensor supply and internal supply voltage (green: OK); UA: actuator supply (green: OK)	
Connections		
Fieldbus	via internal system connection	
Sensor-system/actuator supply	via internal system connection (max. 2×4 A)	
I/O ports	M12 (male) 5-pole, A-coded	
Input		
Sensor type	K, N, J, E, R	
Conversion time (analog)	approx. 65 ms per channel	
Resolution (analog)	15 Bit + sign	
Accuracy	max. ±0.5 % (of range limit)	
Connection	2-wire technology	
Cold junction compensation	inside M12 connector	
Diagnostic		
Communication status	via LED	
Diagnostic via LED	per module and channel	
Diagnostic via BUS	per module and channel	
Monitoring - under voltage	yes	
Monitoring - no voltage	yes	
Short circuit and overload	yes	–
Actuator warning	per channel via LED and BUS	
Wire break upper/lower limit overload	per channel via LED and BUS	
General data		
Protection	IP67	
Mounting method	2-hole screw mounting	
Temperature range	0...+55 °C (storage temperature -20...+75 °C)	
Dimension drawing		
Notes		

CUBE67

Analog outputs

– Voltage/current

Cube67 AO4 C 4×M12

Compact module
Voltage

Cube67 AO4 C 4×M12

Compact module
Current

Cube67 AO4 E 4×M12

Expansion module
Voltage

Cube67 AO4 E 4×M12

Expansion module
Current



Approvals:

Order Data	Art-No.	Art-No.	Art-No.	Art-No.
AO4 - (C) 4×M12 (U)	cULus	56710		
AO4 - (C) 4×M12 (I)		cULus	56720	
AO4 - (E) 4×M12 (U)			56711	
AO4 - (E) 4×M12 (I)				56721

Internal communication				
Current consumption	max. 50 mA			
LED display	US: sensor supply and internal supply voltage (green: OK); UA: actuator supply (green: OK)			
Connections				
Fieldbus	via internal system connection			
Sensor-system/actuator supply	via internal system connection (max. 2×4 A)			
I/O ports	M12 (male) 5-pole, A-coded			
Output				
Supply voltage	24 V DC (EN 61131-2), via system connection (max. 4 A)			
Conversion time (analog)	approx. 1 ms (per channel)			
Actuator supply UA	24 V DC (EN 61131-2), max. 1.6 A per M12 female, (short-circuit and overload protected)			
Resolution (analog)	11 Bit + sign	11 Bit	11 Bit + sign	11 Bit
Accuracy	max. ±0.5 % (of range limit)			
Voltage output signals				
Load	min. 500 Ohm	–	min. 500 Ohm	–
Input range	±10 V DC, 0...10 V DC	–	±10 V DC, 0...10 V DC	–
Current outputs				
Load	–	max. 500 Ohm	–	max. 500 Ohm
Input range	–	0...20 mA, 4...20 mA	–	0...20 mA, 4...20 mA
Diagnostic				
Communication status	via LED			
Diagnostic via LED	per module and channel			
Diagnostic via BUS	per module and channel			
Monitoring - under voltage	yes			
Monitoring - no voltage	yes			
Short circuit and overload	yes			
Actuator warning	per channel via LED and BUS			
Wire break upper/lower limit overload	per channel via LED and BUS			
General data				
Protection	IP67			
Mounting method	2-hole screw mounting			
Temperature range	0...+55 °C (storage temperature -20...+75 °C)			
Dimension drawing				

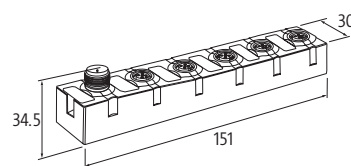
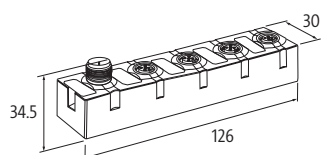

Notes

CUBE67

Expansion module

- Digital outputs



Cube67 DO8 - Valve

Cube67 DO16 - Valve

Cube67 DO32 - Valve



Order Data	Art-No.	Art-No.	Art-No.
with open ended wires (0.5 A)	56655		56656
with open ended wires (70 mA)		56651	
Internal communication			
Current consumption	max. 50 mA		
LED display	US: sensor supply and internal supply voltage (green: OK); UA: actuator supply (green: OK)		
Connections			
Fieldbus	via internal system connection		
Sensor-system/actuator supply	via internal system connection (max. 2x4 A)		
I/O ports	Open cable (0.5 m) 0.5 A	Open cable (0.5 m) 70 mA	Open cable (0.5 m) 0.5 A
Cables			
No./diameter of wires	10 x 0.34 mm ²	18 x 0.25 mm ²	36 x 0.14 mm ²
Material (jacket)	PUR	PVC	
Output			
Actuator supply UA	24 V DC (EN 61131-2), via system connection (max. 4 A)		
Switching current per output	short-circuit and overload protected		
Diagnostic			
Communication status	via LED		
Diagnostic via LED	per module		
Diagnostic via BUS	per module and channel		
Monitoring - under voltage	yes		
Monitoring - no voltage	yes		
Short circuit and overload	yes		
Actuator warning	per channel via BUS		
General data			
Protection	IP67		
Mounting method	2-hole screw mounting		
Temperature range	0...+55 °C (storage temperature -20...+75 °C)		
Dimension drawing			

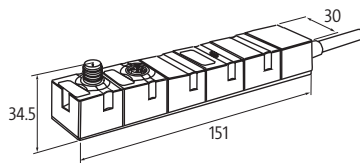

Notes

Compact module

– Digital outputs

Cube67 DO16 - Valve

(4 × actuator supply UA)



Order Data		Art-No.
Multipole plug (0.5 A)	SMC (SUB-D25)	5665000
	SMC - Series SV/VQ	5665002
	FESTO - MPA (SUB-D25)	5665001
	FESTO - CPV (SUB-D25) – GOST	5665004
Internal communication		
Current consumption	max. 50 mA	
LED display	US: sensor supply and internal supply voltage (green: OK); UA: actuator supply (green: OK)	
Connections		
Fieldbus	via internal system connection	
Sensor-system/actuator supply	via internal system connection (max. 1×4 A) / actuators via external cable (max. 4×2 A)	
I/O ports	Cable (0.5 m) / SMC, SUB-D25 (0.5 A)	
Cables		
No./diameter of wires	4 × 4 × 0.14 mm ²	
Material (jacket)	PVC, cross-link safe	
Output		
Actuator supply UA	24 V DC (EN 61131-2), max. 4 × 2 A	
Switching current per output	max. 0.5 A (short-circuit and overload protected)	
Diagnostic		
Communication status	via LED	
Diagnostic via LED	per module	
Diagnostic via BUS	per module and channel	
Monitoring - under voltage	yes	
Monitoring - no voltage	yes	
Short circuit and overload	yes	
Actuator warning	per channel via BUS	
General data		
Protection	IP67	
Mounting method	2-hole screw mounting	
Temperature range	0...+55 °C (storage temperature -20...+70 °C)	
Dimension drawing		

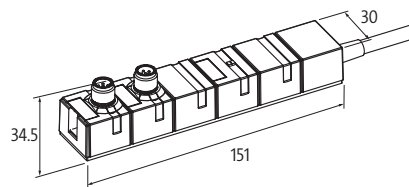

Notes

CUBE67

Cube67

Versions		Art-No.
	based of: Art.-No. 56655	
	Multipole plug (70 mA)	FESTO - CPV 5665500
	Multipole plug (70 mA)	FESTO - CPV (SUB-D9) 5665501
	Multipole plug (70 mA)	FESTO - MPA 5665502
	based of: Art.-No. 56651	
	Multipole plug (70 mA)	FESTO - CPV (cULus-Listed) 5665100
	Multipole plug (70 mA)	PARKER - Series V 5665101
	Multipole plug (70 mA)	NORGREN - V20/22 5665110
	Multipole plug (70 mA)	NORGREN - VM10 5665111
	Multipole plug (70 mA)	NORGREN - V20/22 5665112
	Multipole plug (70 mA)	SMC - Series SV/VQ 5665113
	Multipole plug (70 mA)	SMC - M27 5665114
	Multipole plug (70 mA)	NORGREN - V20/220 5665115
	Multipole plug (0.5 A)	MAC Valves 5665116
	Multipole plug (70 mA)	FESTO - MPA 5665118
	Multipole plug (70 mA)	FESTO - VTSA 5665105
	Multipole plug (70 mA)	FESTO - CPV-SC (SUB-D15) 5665102
Multipole plug (70 mA)	FESTO - CPV-SC (SUB-D26) 5665103	
	based of: Art.-No. 56656	
	Multipole plug (0.5 A)	NORGREN - VM10 5665600
	Multipole plug (0.5 A)	FESTO - MPA 5665601
	Multipole plug (0.5 A)	BOSCH - HF03 5665602
	Multipole plug (0.5 A)	NORGREN - VM10 5665603
	Multipole plug (0.5 A)	SMC - Series SV 5665604
	Multipole plug (0.5 A)	FESTO - CPA 5665605
	Multipole plug (0.5 A)	BOSCH - HF02/03-LG 5665606
	Multipole plug (0.5 A)	SMC - M27 5665607
	Multipole plug (0.5 A)	MAC Valves (UL-Listed) 5665609
	Multipole plug (0.5 A)	VESTA (SUB-D37) 5665610
	Multipole plug (0.5 A)	VESTA (SUB-D25) 5665611
	Multipole plug (0.5 A)	FESTO - VTSA 5665613
	Multipole plug (0.5 A)	SMC - M27 5665614
	Multipole plug (0.5 A)	FESTO - CPA-SC 5665615
	Multipole plug (0.5 A)	FESTO - MPA-L 5665616
Multipole plug (0.5 A)	BOSCH - HF02/03-LG 5665617	
Multipole plug (0.5 A)	Numatics Generation 2000 (UL-Listed) 5665618	
	based of: Art.-No. 56671	
	DI16/DO16 - 0.5 A (E) AMP (0.5 m)	With AMP connector 32-pole (female) 5667100
	DI16/DO16 - 0.5 A (E) SUB-D37 (0.5 m)	with SUB-D37 (female) 5667101
Labeling accessories		Art-No.
	Label plates 20 × 8 mm (20 pieces per plate)	55318
Connection accessories		Art-No.
	Terminator M12 straight, A-coded, 6-pole	Cube67 7000-15041-000000



CUBE20 MODULAR I/O STATION IP20







- High channel density due to compact design
- Modular structure
- I/O connections with maintenance-free terminals

INNOVATIVE INSTALLATION TECHNOLOGY

Cube20 is a modular fieldbus I/O station that's expandable and can be integrated into the Cube67 I/O system. The modules are designed for modern wiring requirements in control cabinets. Using Cube20 reduces unnecessary costs from dealing with many individual components. This is because of its compact design which includes a high channel density of 32 channels per I/O module.



Cube20 I/O Modules

 <p>Bus Nodes</p> <ul style="list-style-type: none"> • PROFIBUS • PROFINET • Ethernet/IP • IP20 protection <p><i>Page 4.2.1</i></p>	 <p>System Connection to Cube67</p> <ul style="list-style-type: none"> • IP20 protection <p><i>Page 4.2.2</i></p>
 <p>Digital Inputs</p> <ul style="list-style-type: none"> • IP20 protection <p><i>Page 4.2.3</i></p>	 <p>Digital Inputs/Outputs</p> <ul style="list-style-type: none"> • IP20 protection <p><i>Page 4.2.3</i></p>
 <p>Digital Outputs</p> <ul style="list-style-type: none"> • IP20 protection <p><i>Page 4.2.3</i></p>	 <p>Analog Inputs</p> <ul style="list-style-type: none"> • IP20 protection <p><i>Page 4.2.4</i></p>
 <p>Analog Outputs</p> <ul style="list-style-type: none"> • IP20 protection <p><i>Page 4.2.6</i></p>	

CUBE20

Bus Nodes

– Digital inputs



Cube20 BN-P DI8



Cube20 BN-E DI8



Cube20 BN-PNIO DI8

Order Data	Art-No.	Art-No.	Art-No.
PROFIBUS DP	56001		
EtherNet-IP		56005	
PROFINET IO			56006
Connections			
Fieldbus	SUB-D9 (female)	2 × RJ45 (female)	
Sensor-system/actuator supply	4 × Spring clamp terminals, max. 2.5 mm ² (max. 12 A)		
I/O ports	8 × Spring clamp plug-in terminals, max. 2.5 mm ²		
Fieldbus			
Operating modes	Sync- and freeze mode are supported	Autonegotiation/Auto MDI/MDI-X	
Transfer rate	to 12 Mbit/s	10/100 Mbit/s full duplex	to 100 Mbit/s Full Duplex
Addressing	Rotary switch 1...99	DHCP, BOOTP or IP address by rotary switch	Name assignment via PROFINET
I/O capacity	with modular expandability by up to 15 Cube-modules		
Input			
Sensor supply US	24 V DC (EN 61131-2), max. 700 mA per module		
Type	PNP (EN 61131-2)		
Input filter	1 ms		
Galvanic isolation	500 V DC between I/O and system electronics		
Parameterization			
Terminal row X2 (4 channels)	Input		
Terminal row X3 (4 channels)	Input		
Module Supply			
Operating voltage	24 V DC (EN 61131-2)		
Sensor-system/actuator supply	via terminal UB		
Current consumption	max. 150 mA		
Diagnostic			
Communication status	per LED and BUS		
Diagnostic via LED	per module		
Diagnostic via BUS	per module and channel		
Monitoring - under voltage	yes		
Monitoring - no voltage	no		
Short circuit and overload	yes		
General data			
Protection	IP20		
Mounting method	DIN-rail mountable (EN 60715)		
Temperature range	0...+55 °C (storage temperature -20...+85 °C)		

Dimension drawing

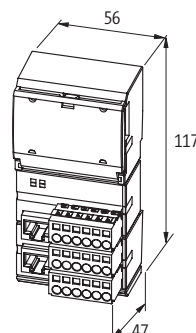
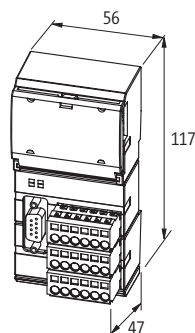

CUBE20

Bus Nodes

– Multifunctional I/Os

– Cube67

Approvals:  

Cube20 BN-67 DIO8

Power external



Cube20 BN-67 DIO8

Power via M12

Order Data	Art-No.	Art-No.
Cube67 system connection	56450	564501
Internal communication		
Current consumption	max. 100 mA	
Connections		
Fieldbus	M12 (male) 6-pole	M12 (female) 6-pole
Sensor-system/actuator supply	4 × Spring clamp terminals, max. 2.5 mm ² (max. 12 A)	via internal system connection (max. 2×4 A)
I/O ports	8 × Spring clamp plug-in terminals, max. 2.5 mm ²	
Cube67 System supply		
I/O capacity	with modular expandability by up to 3 Cube modules	
Input		
Sensor supply US	24 V DC (EN 61131-2), max. 700 mA per module, short-circuit and overload protected	
Type	PNP (EN 61131-2)	
Input filter	1 ms	
Galvanic isolation	500 V DC between I/O and system electronics	
Parameterization		
Terminal row X2 (4 channels)	Input/output	
Terminal row X3 (4 channels)	Input/output	
Output		
Actuator supply UA	24 V DC (EN 61131-2), max. 12 A	24 V DC (EN 61131-2), max. 4 A
Switching current per output	max. 0.5 A (short-circuit and overload protected)	
Galvanic isolation	500 V DC between I/O and system electronics	
Lamp load	10 W	
Module Supply		
Operating voltage	24 V DC (EN 61131-2)	
Sensor-system/actuator supply	via terminal UB	
Diagnostic		
Communication status	via LED	
Diagnostic via LED	per module and channel (only outputs)	
Diagnostic via BUS	per module and channel	
Monitoring - under voltage	yes	
Monitoring - no voltage	no	
Short circuit and overload	yes	
General data		
Protection	IP20	
Mounting method	DIN-rail mountable (EN 60715)	
Temperature range	0...+55 °C (storage temperature -20...+85 °C)	
Dimension drawing		

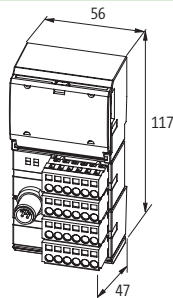

Notes

CUBE20

Expansion module

- Digital inputs
- Digital outputs
- Digital inputs and outputs

Approvals:

Cube20 DI32 E



Cube20 DI16 DO16 E



Cube20 DO16 E



Cube20 DO32 E



Cube20

Order Data	Art-No.	Art-No.	Art-No.	Art-No.
DI32 - (E)	cULus	56112		
DI16/DO16 - (E)			56168	
DO16 - (E)			cULus	56117
DO32 - (E)				cULus 56118
Internal communication				
Module Supply	via system connection			
Current consumption	max. 25 mA			
Connections				
Fieldbus	Ribbon cable connection			
Sensor-system/actuator supply	8 × Spring clamp plug-in terminals, max. 2.5 mm ² (max. 12 A)			
I/O ports	32 × Spring clamp plug-in terminals, max. 2.5 mm ²		16 × Spring clamp plug-in terminals, max. 2.5 mm ²	
Input				
Sensor supply US	24 V DC (EN 61131-2), max. 700 mA per module		-	
Type	PNP (EN 61131-2)		-	
Input filter	1 ms		-	
Galvanic isolation	500 V DC between inputs and internal communication		-	
Output				
Actuator supply UA	-	24 V DC (EN 61131-2), max. 12 A		
Galvanic isolation	-	500 V DC between outputs and internal communication		
Switching current per output	-	max. 0.5 A (short-circuit and over-load protected)	max. 2 A	max. 0.5 A (short-circuit and over-load protected)
Lamp load	-	10 W	40 W	10 W
Diagnostic				
Communication status	via LED			
Diagnostic via LED	per module	per module and channel (only outputs)	per module and channel	
Diagnostic via BUS	per module and channel			
Monitoring - under voltage	yes			
Monitoring - no voltage	no			
Short circuit and overload	yes			
General data				
Protection	IP20			
Mounting method	DIN-rail mountable (EN 60715)			
Temperature range	0...+55 °C (storage temperature -20...+85 °C)			

Dimension drawing

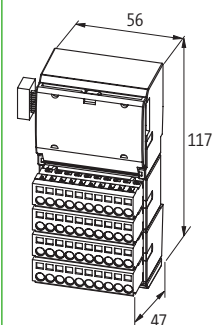
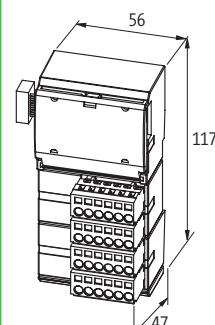
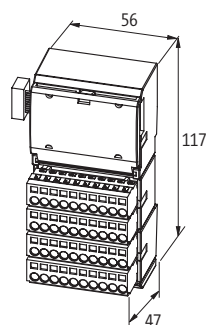

Notes

CUBE20

Analog inputs

– Voltage/current

Cube20 AI4 E

Voltage/current



Approvals:  

Order Data	Art-No.
AI4 - (E)	56200
Internal communication	
Module Supply	via system connection
Current consumption	max. 25 mA from system, max. 60 mA externally (UI)
Connections	
Fieldbus	Ribbon cable connection
Sensor-system/actuator supply	4 × Spring clamp terminals, max. 2.5 mm ² (max. 12 A)
I/O ports	24 × Spring clamp plug-in terminals, max. 2.5 mm ²
Technical Data	
Operating voltage	24 V DC (EN 61131-2)
Input	
Conversion time (analog)	max. 2 ms (per channel)
Resolution (analog)	15 Bit + sign
Accuracy	max. 0.3 %
Connection	Differential voltage/current input
Voltage inputs	
Input resistor	min. 1 MOhm, (EN 61131-2)
Input range	±10 V DC, 0...10 V DC
Current input signals	
Load	max. 300 Ohm (20 mA), (EN 61131-2)
Input range	0...20 mA, 4...20 mA
Diagnostic	
Communication status	via LED
Diagnostic via LED	per module
Diagnostic via BUS	per module and channel
Monitoring - under voltage	yes
Monitoring - no voltage	no
Short circuit and overload	yes
Wire break upper/lower limit overload	per channel via LED and BUS
General data	
Protection	IP20
Mounting method	DIN-rail mountable (EN 60715)
Temperature range	0...+55 °C (storage temperature -40...+85 °C)

Dimension drawing

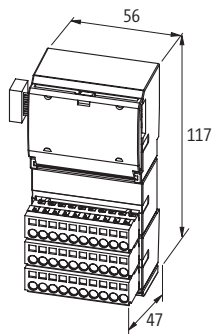

Notes

CUBE20

Analog inputs

– Temperature converter



Cube20 AI4 E RTD for resistors and temperature



Cube20 AI4 E TH for thermo elements



Order Data	Art-No.	Art-No.
AI4 - (E) RTD	56230	
AI4 - (E) TH		56240
Internal communication		
Module Supply	via system connection	
Current consumption	max. 25 mA from system, max. 70 mA externally (UI)	max. 25 mA from system, max. 45 mA externally (UI)
Connections		
Fieldbus	Ribbon cable connection	
Sensor-system/actuator supply	4 × Spring clamp terminals, max. 2.5 mm ² (max. 12 A)	
I/O ports	16 × Spring clamp plug-in terminals, max. 2.5 mm ²	12 × Spring clamp plug-in terminals, max. 2.5 mm ²
Technical Data		
Operating voltage	24 V DC (EN 61131-2)	
Input		
Conversion time (analog)	max. 600 ms (per channel)	max. 300 ms (per channel)
Type	Pt100, 200, 500; Ni100, 120, 200, 500, 1000, R 0...3000 Ohm	K, N, E, J, R
Resolution (analog)	15 Bit + sign	
Accuracy	0.7...1.4 %	max. ±2 %, cold junction compensation
Connection	2-wire input: +Rx, -Rx / 3-wire input: +Rx, RLx, -Rx	2-wire input; TH+x, TH-x
Diagnostic		
Communication status	via LED	
Diagnostic via LED	per module	
Diagnostic via BUS	per module and channel	
Monitoring - under voltage	yes	
Monitoring - no voltage	no	
Short circuit and overload	yes	
Wire break upper/lower limit overload	per channel via LED and BUS	
General data		
Protection	IP20	
Mounting method	DIN-rail mountable (EN 60715)	
Temperature range	0...+55 °C (storage temperature -20...+85 °C)	

Dimension drawing

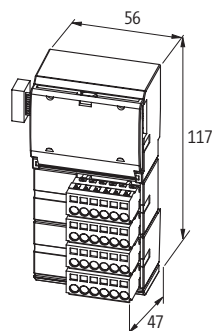

Notes

CUBE20

Analog outputs

– Voltage/current

Cube20 AO4 E

Expansion module
Voltage/current



Approvals:  

Order Data	Art-No.
AO4 - (E) U/I	56220
Internal communication	
Module Supply	via system connection
Current consumption	max. 25 mA from system, max. 90 mA externally (UI), idle load
Connections	
Fieldbus	Ribbon cable connection
Sensor-system/actuator supply	4 × Spring clamp terminals, max. 2.5 mm ² (max. 12 A)
I/O ports	24 × Spring clamp plug-in terminals, max. 2.5 mm ²
Technical Data	
Operating voltage	24 V DC (EN 61131-2)
Output	
Conversion time (analog)	max. 1 ms (per channel)
Resolution (analog)	15 Bit + sign
Accuracy	max. 0.5 %
Galvanic isolation	500 V DC between inputs and internal communication
Voltage output signals	
Load	min. 1 kOhm, (EN 61131-2)
Input range	±10 V DC, 0...10 V DC
Current outputs	
Load	max. 600 Ohm, (EN 61131-2)
Input range	0...20 mA, 4...20 mA
Diagnostic	
Communication status	via LED
Diagnostic via LED	per module and channel
Diagnostic via BUS	per module and channel
Monitoring - under voltage	yes
Monitoring - no voltage	no
Short circuit and overload	yes
Actuator warning	per channel via LED and BUS
Wire break upper/lower limit overload	per channel via LED and BUS
General data	
Protection	IP20
Mounting method	DIN-rail mountable (EN 60715)
Temperature range	0...+55 °C (storage temperature -20...+85 °C)

Dimension drawing

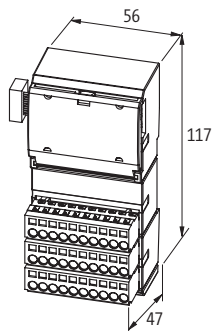

Notes



CUBE20S

SMALL, SPEEDY, SAFE

- Extremely modular
- Up to 64 modules per bus node
- Quick reaction time: up to 20 μ s

A NEW MEMBER OF THE CUBE FAMILY

Murrelektronik's modular Cube20S I/O system expands the field-tested Cube family with another product line that is extremely useful. Designed in the same compact shape, it's highly flexible like all our Cube modules.

The small modules are only 12.9 millimeters wide and modularly designed, which saves space. Connections are also quick and easy to make thanks to the integrated backplane with power supply.

Bus nodes for Cube20S are available for all standard fieldbus protocols.



Cube20S I/O Modules

 <p>Bus Nodes / Power Modules • IP20 protection</p> <p><i>Page 4.3.1</i></p>	 <p>Function Modules • IP20 protection</p> <p><i>see onlineshop.murrelektronik.com/en</i></p>
 <p>Digital Inputs • IP20 protection</p> <p><i>Page 4.3.3</i></p>	 <p>Digital Outputs • IP20 protection</p> <p><i>Page 4.3.4</i></p>
 <p>Analog Inputs • IP20 protection</p> <p><i>see onlineshop.murrelektronik.com/en</i></p>	 <p>Analog Outputs • IP20 protection</p> <p><i>see onlineshop.murrelektronik.com/en</i></p>

CUBE20S

Bus Nodes

– Power module included



Cube20S



Order Data	Art-No.	Art-No.	Art-No.
PROFIBUS DP	57101		
DeviceNet		57107	
CANopen			57104
Fieldbus			
Operating modes	Sync- and freeze mode are supported		
Transfer rate	max. 12 Mbit/s	max. 500 kbit/s	max. 1 Mbit/s
Addressing	DIP switch		
Connector	SUB-D9 (female)	5-pole Open-Style Connector	SUB-D9
I/O capacity	with modular expandability by up to 64 Cube20S I/O modules and function modules		
Output			
Output voltage (I/Os /Backplane)	24 V DC /5 V DC		
Output current (I/Os /Backplane)	10 A/3 A		
Module Supply			
Operating voltage	24 V DC (EN 61131-2)		
Sensor-system/actuator supply	via terminal		
Current consumption	max. 95 mA		
Diagnostic			
Communication status	via LED		
Diagnostic via LED	per module and channel		
Diagnostic via BUS	per module		
Monitoring - under voltage	no		
Monitoring - no voltage	yes		
Short circuit and overload	yes		
Actuator warning	no		
General data			
Protection	IP20		
Connection	Spring clamp plug-in terminals: max. 1.5 mm ² (max. 10 A)		
Mounting method	DIN-rail mountable (EN 60715)		
Temperature range	0...+60 °C (storage temperature -25...+70 °C)		
Dimension drawing			

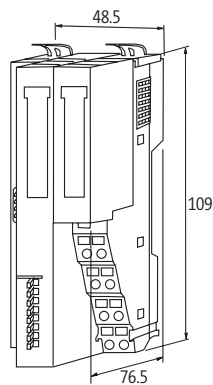

Notes

CUBE20S

Bus Nodes

– Power module included



Approvals: UL US Listed

Cube20S



Order Data	Art-No.	Art-No.	Art-No.	Art-No.
PROFINET IO	57106			
EtherNet-IP		57105		
EtherCAT			57103	
Modbus TCP				57108
Fieldbus				
Operating modes	Sync- and freeze mode are supported			
Transfer rate	max. 100 Mbit/s			
Addressing	DIP/DCP	DIP/DHCP	automatic	
Connector	2 × RJ45 (female)		–	1 × RJ45
I/O capacity	with modular expandability by up to 64 Cube20S I/O modules and function modules			
Output				
Output voltage (I/Os /Backplane)	24 V DC/5 V DC			
Output current (I/Os /Backplane)	10 A/3 A			
Module Supply				
Operating voltage	24 V DC (EN 61131-2)			
Sensor-system/actuator supply	via terminal			
Current consumption	max. 95 mA			
Diagnostic				
Communication status	via LED			
Diagnostic via LED	per module and channel			
Diagnostic via BUS	per module			
Monitoring - under voltage	no			
Monitoring - no voltage	yes			
Short circuit and overload	yes			
Actuator warning	no			
General data				
Protection	IP20			
Connection	Spring clamp plug-in terminals: max. 1.5 mm ² (max. 10 A)			
Mounting method	DIN-rail mountable (EN 60715)			
Temperature range	0...+60 °C (storage temperature -25...+70 °C)			
Dimension drawing				

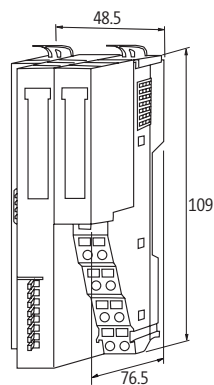

Notes

CUBE20S

Digital inputs

Cube20S



Approvals:  UL
Listed

Order Data		Art-No.
DI2 - (E)		57220
DI4 - (E)		57240
DI8 - (E)		57280
Internal communication		
Module Supply	via system connection	
Current consumption	max. 55 mA	
Input		
Sensor supply US	24 V DC (EN 61131-2), max. 500 mA per module	
Type	n-switching (EN 61131-2)	
Input filter	3 ms	
Galvanic isolation	500 V DC between inputs and internal communication	
Diagnostic		
Communication status	via LED	
Diagnostic via LED	per module and channel	
Diagnostic via BUS	per module	
Monitoring - under voltage	no	
Monitoring - no voltage	yes	
Short circuit and overload	yes	
General data		
Protection	IP20	
Connection	Spring clamp plug-in terminals: max. 1.5 mm ² (AWG 16)	
Mounting method	DIN-rail mountable (EN 60715)	
Temperature range	0...+60 °C (storage temperature -20...+70 °C)	
Dimension drawing		

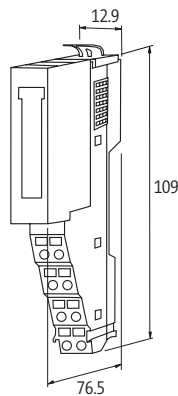

Notes	

CUBE20S

Digital outputs

Cube20S



Approvals:  UL US
Listed

Cube20S

Order Data	Art-No.
DO2 - (E)	57320
DO4 - (E)	57340
DO8 - (E)	57380

Internal communication

Module Supply	via system connection
Current consumption	max. 55 mA

Output

Actuator supply UA	24 V DC (EN 61131-2), max. 1 A
Switching current per output	max. 0.5 A (short-circuit and overload protected)
Galvanic isolation	500 V DC between outputs and internal communication
Lamp load	5 W
Output delay time	175 ns

Diagnostic

Communication status	via LED
Diagnostic via LED	per module and channel
Diagnostic via BUS	per module
Monitoring - under voltage	yes
Monitoring - no voltage	no
Short circuit and overload	yes

General data

Protection	IP20
Connection	Spring clamp plug-in terminals: max. 1.5 mm ² (AWG 16)
Mounting method	DIN-rail mountable (EN 60715)
Temperature range	0...+60 °C (storage temperature -25...+70 °C)

Dimension drawing

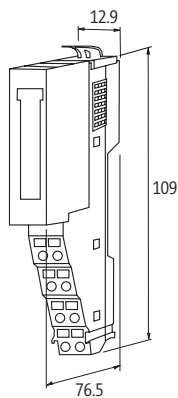

Notes

CUBE20S

Digital outputs

Cube20S - 2 A

Cube20S - 230 V AC (Relays)



Approvals:  UL_{us}
Listed

Order Data	Art-No.	Art-No.
DO2 - (E)	57325	57327
DO4 - (E)	57345	
Internal communication		
Module Supply	via system connection	
Current consumption	max. 60 mA	max. 130 mA
Output		
Actuator supply UA	24 V DC (EN 61131-2), max. 4 A	max. 30 V DC/230 V AC
Switching current per output	max. 2 A (short-circuit and overload protected)	max. 3 A (short-circuit and overload protected)
Galvanic isolation	500 V DC between outputs and internal communication	
Lamp load	10 W	–
Diagnostic		
Communication status	via LED	
Diagnostic via LED	per module and channel	
Diagnostic via BUS	per module	
Monitoring - under voltage	yes	
Monitoring - no voltage	no	
Short circuit and overload	yes	
General data		
Protection	IP20	
Connection	Spring clamp plug-in terminals: max. 1.5 mm ² (AWG 16)	
Mounting method	DIN-rail mountable (EN 60715)	
Temperature range	0...+60 °C (storage temperature -25...+70 °C)	
Dimension drawing		

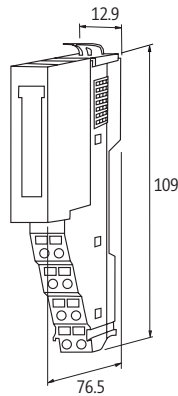

Notes



MVK METAL COMPACT I/O MODULES FOR DEMANDING REQUIREMENTS

- Tough and reliable
- Safe (safety circuits according to EN 13849-1 up to PL e)
- PROFINET – versions compliant with AIDA

MAXIMUM FLEXIBILITY

MVK Metal features a robust metal housing and is extremely resistant to vibration, media, and weld splatter.

- Double valves occupy only one M12 port.
- PROFINET versions with Fast Start Up (< 500 ms)
- Models with multi-functional I/Os
- Fewer variations required, minimizes inventory costs
- Maximum flexibility for expansions

DON'T LOOK FOR ERRORS, FIND THEM

MVK Metal's diagnostic options offer detailed information about the type and location of the failure or the error.

- Only the affected port shuts down, not the whole module
- Detailed message sent to controls and device LED
- Minimizes downtime – failures are fixed faster



MVK Metal I/O Modules



MVK-MP

- Multi-functional I/Os
- I/O link
- Safety outputs
- Analog I/Os



see onlineshop.murrelektronik.com/en



MVK-MPNIO

- Multi-functional I/Os
- Digital I/Os
- AIDA Push Pull
- Safety inputs/outputs
- Fast Start Up



Page 4.4.1



MVK-MC

- Multi-functional I/Os



see onlineshop.murrelektronik.com/en

MVK METAL

Expanded diagnostic

- 7/8"



MVK-MPNIO



Order Data	Art-No.	Art-No.	Art-No.
DI8 (DI8)	55287		
DIO8 (DI8)		55288	
DIO8 (DIO8)			55289
Connections			
Fieldbus	M12, D-coded		
Sensor-system/actuator supply	7/8", 5-pole, 2 x max. 9 A		
I/O ports	M12, A-coded, 5-pole		
Fieldbus			
Operating voltage	24 V DC (EN 61131-2)		
Operating modes	Autonegotiation/Auto MDI/MDI-X		
Transfer rate	to 100 Mbit/s Full Duplex		
Addressing	DCP		
Input			
Sensor supply US	24 V DC (EN 61131-2), max. 200 mA (M12 female), short-circuit and overload protected		
Type	for 3-wire sensors or mechanical switches, p-switching (EN 61131-2)		
Parameterization			
PIN 4	Input	Input/output	
PIN 2	Input/diagnostic	Input/output/diagnostic	
Output			
Actuator supply UA	-	24 V DC (EN 61131-2), max. 9 A	
Switching current per output	-	max. 1.6 A (short-circuit and overload protected)	
Lamp load	-	10 W	
Diagnostic			
Communication status	via LED		
Diagnostic via LED	per module and channel		
Diagnostic via BUS	per module and channel		
Monitoring - under voltage	yes		
Monitoring - no voltage	yes		
Short circuit and overload	yes		
Actuator warning	per channel via LED and BUS		
Cable break	per port		
General data			
Protection	IP67		
Mounting method	2-hole screw mounting		
Temperature range	-25...+55 °C (storage temperature -25...+70 °C)		
Dimension drawing			

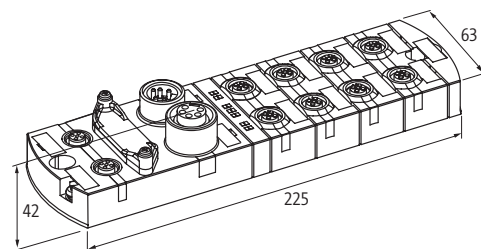

Notes



IMPACT67 COMPACT I/O MODULES FOR THE FIELD

- Application oriented
- Easy to Install
- Cost-effective

ECONOMIC DECENTRALIZATION

Impact67 is the perfect fieldbus solution for basic applications that need to be cost-effective. The modules in this series are available with different bus protocols, they feature pluggable connections, diagnostics and IP67 tested seals.

This makes Impact67 the perfect choice for an electrical engineer whose objective is to minimize costs while maintaining digital inputs and outputs under ordinary conditions.

FOCUSED ON ESSENTIALS

- Predefined inputs and outputs – helps facilitate configuration
- Single channel diagnostic via LED – don't look for errors, find them
- Group diagnostics via the bus – easy remote diagnostics
- Port-related shut off – only the affected port is shut off



Impact67 I/O Modules

 <p>Impact67-P • Digital I/Os</p>  <p>Page 4.5.1</p>	 <p>Impact67-PNIO • Digital I/Os</p>  <p>Page 4.5.2</p>
 <p>Impact67-E • Digital I/Os</p>  <p>Page 4.5.3</p>	 <p>Impact67-EC • Digital I/Os</p>  <p>Page 4.5.4</p>
 <p>Impact67-C • Digital I/Os</p>  <p>Page 4.5.5</p>	 <p>Impact67-DN • Digital I/Os</p>  <p>Page 4.5.6</p>

IMPACT67

Basic diagnostic



Impact67-P

DI16

Impact67-P

DI8/DO8 - 2 A

Impact67-P

DO8 - 2 A

Impact67-P

DO16 - 0.5 A



Order Data	Art-No.	Art-No.	Art-No.	Art-No.
DI16	55345			
DI8/DO8 - 2 A		55346		
DO8 - 2 A			55347	
DO16 - 0.5 A				55348

Connections	
Fieldbus	M12, B-coded
Sensor-system/actuator supply	7/8", 5-pole, 2 × max. 9 A
I/O ports	M12, A-coded, 5-pole
Fieldbus	
Operating voltage	24 V DC (EN 61131-2)
Operating modes	Sync- and freeze mode are supported
Transfer rate	to 12 Mbit/s
Addressing	Rotary switch 3...99
Input	
Sensor supply US	24 V DC (EN 61131-2), max. 200 mA (M12 female), short-circuit and overload protected
Type	for 3-wire sensors or mechanical switches, p-switching (EN 61131-2)
Output	
Switching current per output	max. 2 A (short-circuit and overload protected) / max. 0.5 A (short-circuit and overload protected)
Diagnostic	
Communication status	via LED
Diagnostic via LED	per module and channel
Diagnostic via BUS	per module / per module and channel
Monitoring - under voltage	yes
Monitoring - no voltage	yes
Short circuit and overload	yes
General data	
Protection	IP67
Mounting method	2 hole screw mounting, compatible with I/O modules of MVK model range
Temperature range	0...+55 °C (storage temperature -25...+70 °C)
Dimension drawing	

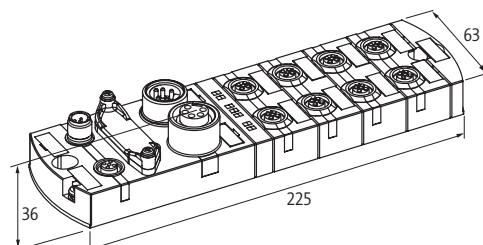

Notes

IMPACT67

Basic diagnostic



Impact67-PN

DI16

Impact67-PN

DI8/DO8 - 2 A

Impact67-PN

DO8 - 2 A

Impact67-PN

DO16 - 0.5 A



Order Data	Art-No.	Art-No.	Art-No.	Art-No.
DI16	55091			
DI8/DO8 - 2 A		55092		
DO8 - 2 A			55093	
DO16 - 0.5 A				55094

Connections

Fieldbus	M12, D-coded
Sensor-system/actuator supply	7/8", 5-pole, 2 × max. 9 A
I/O ports	M12, A-coded, 5-pole

Fieldbus

Operating voltage	24 V DC (EN 61131-2)
Operating modes	Autonegotiation/Auto MDI/MDI-X
Transfer rate	to 100 Mbit/s Full Duplex
Addressing	DCP

Input

Sensor supply US	24 V DC (EN 61131-2), max. 200 mA (M12 female), short-circuit and overload protected	-
Type	for 3-wire sensors or mechanical switches, p-switching (EN 61131-2)	-

Output

Switching current per output	-	max. 2 A (short-circuit and overload protected)	max. 0.5 A (short-circuit and overload protected)
------------------------------	---	---	---

Diagnostic

Communication status	via LED	
Diagnostic via LED	per module and channel	
Diagnostic via BUS	per module	per module and channel
Monitoring - under voltage	yes	
Monitoring - no voltage	yes	
Short circuit and overload	yes	-

General data

Protection	IP67
Mounting method	2 hole screw mounting, compatible with I/O modules of MVK model range
Temperature range	-25...+55 °C (storage temperature -25...+70 °C)

Dimension drawing

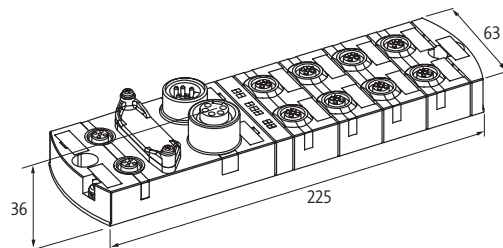

Notes

IMPACT67

Basic diagnostic

EtherNet/IP™
conformance tested

Impact67-E

DI16

Impact67-E

DI8/DO8 - 2 A

Impact67-E

DO8 - 2 A

Impact67-E

DO16 - 0.5 A



Approvals:   

Order Data	Art-No.	Art-No.	Art-No.	Art-No.
DI16	55085			
DI8/DO8 - 2 A		55086		
DO8 - 2 A			55087	
DO16 - 0.5 A				55088

Connections	
Fieldbus	M12, D-coded
Sensor-system/actuator supply	7/8", 5-pole, 2 × max. 9 A
I/O ports	M12, A-coded, 5-pole
Fieldbus	
Operating voltage	24 V DC (EN 61131-2)
Operating modes	Autonegotiation/Auto MDI/MDI-X
Transfer rate	to 100 Mbit/s Full Duplex
Addressing	DHCP, BOOTP or IP address by rotary switch
Input	
Sensor supply US	24 V DC (EN 61131-2), max. 200 mA (M12 female), short-circuit and overload protected
Type	for 3-wire sensors or mechanical switches, p-switching (EN 61131-2)
Output	
Switching current per output	max. 2 A (short-circuit and overload protected)
	max. 0.5 A (short-circuit and overload protected)
Diagnostic	
Communication status	via LED
Diagnostic via LED	per module and channel
Diagnostic via BUS	per module
Monitoring - under voltage	yes
Monitoring - no voltage	yes
Short circuit and overload	yes
General data	
Protection	IP67
Mounting method	2 hole screw mounting, compatible with I/O modules of MVK model range
Temperature range	-25...+55 °C (storage temperature -25...+70 °C)
Dimension drawing	

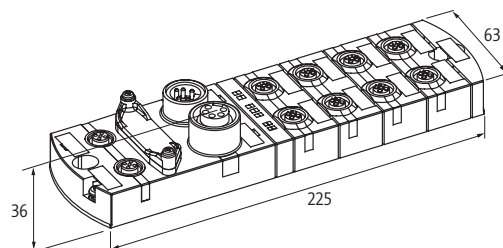

Notes

Impact67

IMPACT67

Basic diagnostic

EtherCAT

Approvals:   

Impact67-EC
DI16

Impact67-EC
DI8/DO8 - 2 A

Impact67-EC
DO8 - 2 A

Impact67-EC
DO16 - 0.5 A



Order Data	Art-No.	Art-No.	Art-No.	Art-No.
DI16	55081			
DI8/DO8 - 2 A		55082		
DO8 - 2 A			55083	
DO16 - 0.5 A				55084

Connections

Fieldbus	M12, D-coded
Sensor-system/actuator supply	7/8", 5-pole, 2 × max. 9 A
I/O ports	M12, A-coded, 5-pole

Fieldbus

Operating voltage	24 V DC (EN 61131-2)
Operating modes	Autocrossing Autonegotiation
Transfer rate	to 100 Mbit/s
Addressing	automatic or Device ID by rotary switch

Input

Sensor supply US	24 V DC (EN 61131-2), max. 200 mA (M12 female), short-circuit and overload protected	–
Type	for 3-wire sensors or mechanical switches, p-switching (EN 61131-2)	–

Output

Switching current per output	–	max. 2 A (short-circuit and overload protected)	max. 0.5 A (short-circuit and overload protected)
------------------------------	---	---	---

Diagnostic

Communication status	via LED
Diagnostic via LED	per module and channel
Diagnostic via BUS	per module per module and channel
Monitoring - under voltage	yes
Monitoring - no voltage	yes
Short circuit and overload	yes

General data

Protection	IP67
Mounting method	2 hole screw mounting, compatible with I/O modules of MVK model range
Temperature range	-25...+55 °C (storage temperature -25...+70 °C)

Dimension drawing

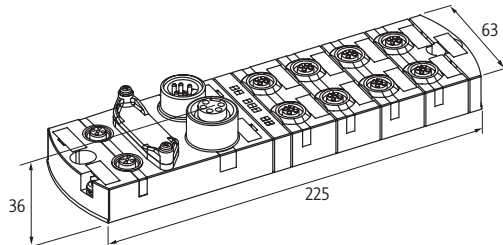

Notes

IMPACT67

Basic diagnostic

CANopen

Impact67-C

DI16

Impact67-C

DI8/DO8 - 2 A

Impact67-C

DO8 - 2 A

Impact67-C

DO16 - 0.5 A



Approvals:   

Order Data	Art-No.	Art-No.	Art-No.	Art-No.
DI16	55075			
DI8/DO8 - 2 A		55076		
DO8 - 2 A			55077	
DO16 - 0.5 A				55078

Connections	
Fieldbus	M12, A-coded
Sensor-system/actuator supply	7/8", 5-pole, 2 × max. 9 A
I/O ports	M12, A-coded, 5-pole
Fieldbus	
Operating voltage	24 V DC (EN 61131-2)
Operating modes	Polling; change of state; Cyclic
Transfer rate	max. 1 Mbit/s
Addressing	Rotary switch 1...99
Input	
Sensor supply US	24 V DC (EN 61131-2), max. 200 mA (M12 female), short-circuit and overload protected
Type	for 3-wire sensors or mechanical switches, p-switching (EN 61131-2)
Output	
Switching current per output	max. 2 A (short-circuit and overload protected)
	max. 0.5 A (short-circuit and overload protected)
Diagnostic	
Communication status	via LED
Diagnostic via LED	per module and channel
Diagnostic via BUS	per module per module and channel
Monitoring - under voltage	yes
Monitoring - no voltage	yes
Short circuit and overload	yes
General data	
Protection	IP67
Mounting method	2 hole screw mounting, compatible with I/O modules of MVK model range
Temperature range	-25...+70 °C (storage temperature -25...+70 °C)
Dimension drawing	

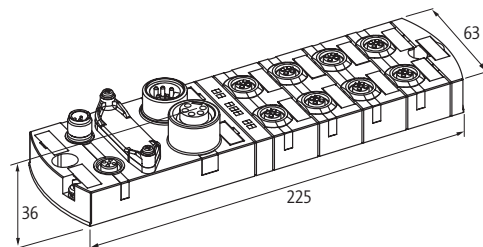

Notes

Impact67

IMPACT67

Basic diagnostic



Impact67-DN
DI16

Impact67-DN
DI8/DO8 - 2 A

Impact67-DN
DO8 - 2 A

Impact67-DN
DO16 - 0.5 A



Order Data	Art-No.	Art-No.	Art-No.	Art-No.
DI16	55071			
DI8/DO8 - 2 A		55072		
DO8 - 2 A			55073	
DO16 - 0.5 A				55074

Connections

Fieldbus	M12, A-coded
Sensor-system/actuator supply	7/8", 5-pole, 2 × max. 9 A
I/O ports	M12, A-coded, 5-pole

Fieldbus

Operating voltage	24 V DC (EN 61131-2)
Operating modes	Polling; change of state; Cyclic
Transfer rate	125 kbit/s; 250 kbit/s; 500 kbit/s
Addressing	Rotary switch 0...63

Input

Sensor supply US	24 V DC (EN 61131-2), max. 200 mA (M12 female), short-circuit and overload protected	-
Type	for 3-wire sensors or mechanical switches, p-switching (EN 61131-2)	-

Output

Switching current per output	-	max. 2 A (short-circuit and overload protected)	max. 0.5 A (short-circuit and overload protected)
------------------------------	---	---	---

Diagnostic

Communication status	via LED
Diagnostic via LED	per module and channel
Diagnostic via BUS	per module per module and channel
Monitoring - under voltage	yes
Monitoring - no voltage	yes
Short circuit and overload	yes

General data

Protection	IP67
Mounting method	2 hole screw mounting, compatible with I/O modules of MVK model range
Temperature range	-25...+70 °C (storage temperature -25...+70 °C)

Dimension drawing

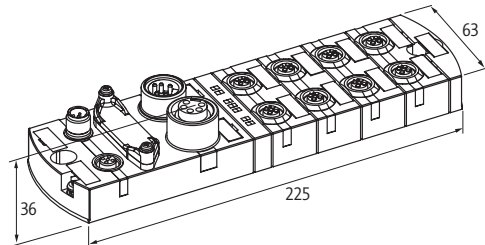

Notes



IMPACT20 COMPACT I/O MODULES

- IP20 protection
- Efficient
- Cost-effective













FOCUSED ON THE ESSENTIALS

Murrelektronik's Impact20 is the perfect solution when you need a cost-effective application of fieldbus I/O modules in terminal boxes and control panels.

- **Predefined Inputs and Outputs**
 - Helps facilitate configuration
- **Single Channel Diagnostic via LED**
 - Indicates failures on the spot
- **Group Diagnostic via the Bus**
 - Facilitates failure analysis
- **Channel-Related Shut Down**
 - Only the affected channel is shutdown



Impact20 I/O Modules

 <p>Impact20-P • Digital I/Os</p>  <p style="text-align: right;"><i>Page 4.6.1</i></p>	 <p>Impact20-PNIO • Digital I/Os</p>  <p style="text-align: right;"><i>see onlineshop.murrelektronik.com/en</i></p>
 <p>Impact20-E • Digital I/Os</p>  <p style="text-align: right;"><i>see onlineshop.murrelektronik.com/en</i></p>	 <p>Impact20-EC • Digital I/Os</p>  <p style="text-align: right;"><i>see onlineshop.murrelektronik.com/en</i></p>
 <p>Impact20-C • Digital I/Os</p>  <p style="text-align: right;"><i>see onlineshop.murrelektronik.com/en</i></p>	 <p>Impact20-DN • Digital I/Os</p>  <p style="text-align: right;"><i>see onlineshop.murrelektronik.com/en</i></p>

IMPACT20



Impact20-P

DI16



Impact20-P

DI8/DO8 - 2 A

Impact20-P

DO16 - 0.5 A



Order Data	Art-No.	Art-No.	Art-No.
DI16	56900		
DI8/DO8 - 2 A		56901	
DO16 - 0.5 A			56902
Connections			
Fieldbus	SUB-D9		
Sensor-system/actuator supply	6 × spring clamp plug-in terminals, max. 2.5 mm ² (max. 12 A)		
I/O ports	18 × spring clamp plug-in terminals, max. 2.5 mm ² (max. 12 A)		
Fieldbus			
Operating voltage	24 V DC (EN 61131-2)		
Operating modes	Sync- and freeze mode are supported		
Transfer rate	to 12 Mbit/s		
Addressing	Rotary switch 3...99		
Input			
Sensor supply US	24 V DC (EN 61131-2), max. 700 mA per module, short-circuit and overload protected		–
Type	for 3-wire sensors or mechanical switches, p-switching (EN 61131-2)		–
Output			
Switching current per output	–	max. 2 A (short-circuit and overload protected)	max. 0.5 A (short-circuit and overload protected)
Total current	–	max. 8 A	
Diagnostic			
Communication status	via LED		
Diagnostic via LED	per module	per module and channel	
Diagnostic via BUS	per module	per module and channel	
Monitoring - under voltage	yes		
Monitoring - no voltage	yes		
Short circuit and overload	yes		
General data			
Protection	IP20		
Mounting method	DIN-rail mountable (EN 60715)		
Temperature range	0...+55 °C (storage temperature -20...+70 °C)		

Dimension drawing

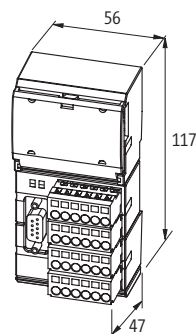

Notes



MASI00/20 FOR THE CONTROL CABINET

- High signal density in a very small space
- Pluggable cutting clamp or spring clamp connections
- Sensor supply from AS Interface or 24 V DC

AS-INTERFACE SYSTEM – MASI00/20

MASI00 and MASI20 modules are designed to correctly support the single strand wiring used in control cabinets and terminal boxes. This gives the user the advantage during installation, setup and maintenance. The modules have a slim design which makes them the perfect choice for applications in terminal boxes and cabinets. The coded, pluggable connections reduce time and errors during installation.

They are designed according to the latest 3.0 AS Interface specification and have the globally recognized AS Interface certification, which guarantees that they are interoperable and a secure investment. Furthermore, with the special K3 module you can create safety shutdowns according to EN 13849-1 up to PL d.



I/O Modules



MASI00 bus components

Page 4.7.1



MASI20 bus components

Page 4.7.1

Installation Technology



Bus and power distributors

see onlineshop.murrelektronik.com/en

System Componente



- Gateways
- Power Supplies

Page 4.7.5

Digital inputs/outputs

MASI00
DI4/DO4 - 0.2 A



MASI00
DI4/DO4 - 0.2 A (AB)

MASI20
DI4 - 0.17 A (AB)



Approvals:

Order Data	Art-No.	Art-No.	Art-No.
DI4/DO4 - 0.2 A	55700		
DI4/DO4 - 0.2 A (AB)		ASI	55701
DI4 - 0.17 A (AB)			ASI, UL-Listed, CSA 55688
Technical Data			
Bus voltage (AS-Interface)	26.5...31.6 V DC		
Total current (AS-Interface)	max. 250 mA		
Addressing	1...31 via plug terminals	1...62 (1...31 A or B) via plug-in terminal	via built-in address port or master
Address range	1...31	1...62 (1...31 A or B)	
Current consumption	–	max. 200 mA	–
Profile (IO/ID/ID2 code)	S-7.F.F	S-7.A.7	S-0.A.0
Input			
Sensor supply US	max. 200 mA from AS-Interface (short-circuit and overload protected)		max. 170 mA from AS-Interface (short-circuit and overload protected)
Type	for standard switches		for 3-wire sensors or mechanical switches, p-switching (EN 61131-2)
Input current	–	max. 10 mA	
Output			
Switching current per output	max. 0.2 A (short-circuit and overload protected)		–
Total current	max. 200 mA		–
Switch off time in case of short circuit	approx. 50 ms		–
Diagnostic			
Communication status	via LED		
Diagnostic via LED	per module		
Monitoring - no voltage	yes		
General data			
Protection	IP00		IP20
Mounting method	DIN-rail mountable (EN 60715)		
Connection AS-Interface	Screw plug-in terminal: 0.2...2.5 mm ²		IDC terminals: 0.5...0.75 mm ²
Temperature range	0...+55 °C (storage temperature -20...+70 °C)		-20...+60 °C
Connection sensor/actuator	–		Spring clamp plug-in terminals: 0.14...1.5 mm ²
Dimension drawing			
Notes			
For DIN-rail mounting use 1 × Art.-No. 20900 adapter feet			

MASI00/20

Digital inputs

– Semiconductor outputs



MASI20

DI4 - 0.2 A DO3 - 0.5 A (AB)



MASI20

DI4 - 0.2 A DO4 - 0.5 A

Order Data	Art-No.	Art-No.
DI4 - 0.2 A DO3 - 0.5 A (AB)	55687	
DI4 - 0.2 A DO4 - 0.5 A		55686
Technical Data		
Bus voltage (AS-Interface)	26.5...31.6 V DC	
Total current (AS-Interface)	max. 50 mA	
Addressing	via built-in address port or master	
Address range	1...62 (1...31 A or B)	1...31
Profile (IO/ID/ID2 code)	S-7.A.0	S-7.0.E
Input		
Sensor supply US	max. 200 mA external POWER, (short-circuit and overload protected)	
Type	for 3-wire sensors or mechanical switches, p-switching (EN 6131-2)	
Input current	max. 10 mA	
Output		
Switching current per output	max. 0.5 A (short-circuit and overload protected)	
Total current	max. 2 A	
Switch off time in case of short circuit	approx. 20 ms	
Diagnostic		
Communication status	via LED	
Diagnostic via LED	per module	
Monitoring - no voltage	yes	
General data		
Protection	IP20	
Connection AS-Interface/Power	IDC terminals: 0.5...0.75 mm ²	
Connection sensor/actuator	Spring clamp plug-in terminals: 0.14...1.5 mm ²	
Mounting method	DIN-rail mountable (EN 60715)	
Temperature range	-20...+60 °C	
Dimension drawing		

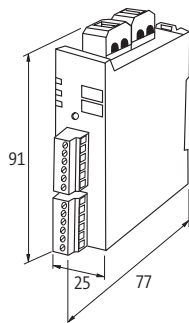

Notes

MASI00/20

Digital inputs

– Relay outputs



MASI20

DI4 - 0.17 A DO3 - 2 A (AB)



MASI20

DI4 - 0.2 A DO4 - 2 A

Order Data	Art-No.	Art-No.
DI4 - 0.17 A DO3 - 2 A (AB)	55768	
DI4 - 0.2 A DO4 - 2 A		55685
Technical Data		
Bus voltage (AS-Interface)	26.5...31.6 V DC	
Total current (AS-Interface)	max. 300 mA	
Addressing	via built-in address port or master	
Address range	1...62 (1...31 A or B)	1...31
Profile (IO/ID/ID2 code)	S-7.A.0	S-7.0.E
Input		
Sensor supply US	max. 170 mA from AS-Interface (short-circuit and overload protected)	max. 200 mA
Type	for 3-wire sensors or mechanical switches, p-switching (EN 61131-2)	
Input current	max. 10 mA	
Output		
Switching current per output	max. 2 A (short-circuit and overload protected)	
Total current	max. 4.5 A	
Diagnostic		
Communication status	via LED	
Diagnostic via LED	per module	
Monitoring - no voltage	yes	
General data		
Protection	IP20	
Connection AS-Interface/Power	IDC terminals: 0.5...0.75 mm ²	
Connection sensor/actuator	Spring clamp plug-in terminals: 0.14...1.5 mm ²	
Mounting method	DIN-rail mountable (EN 60715)	
Temperature range	-20...+60 °C	
Dimension drawing		

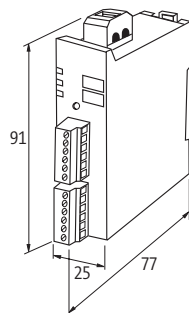

Notes

MASI00/20

Digital inputs

– output groups up to PLd (EN ISO 13849-1) can be switched off via safety relays

– Opto decoupled inputs (only with additional supply voltage)

Approvals:  

MASI20

DI4 - 0.2 A DO4 - 0.5 A (AB) K3



Order Data	Art-No.
DI4 - 0.2 A DO4 - 0.5 A (AB) K3	56440
Technical Data	
Bus voltage (AS-Interface)	26.5...31.6 V DC
Total current (AS-Interface)	max. 300 mA
Addressing	via built-in address port or master
Address range	1...62 (1...31 A or B)
Profile (IO/ID/ID2 code)	S-7.A.7
Input	
Supply voltage	alternatively (switchable) from AS-Interface or from 24 V DC (EN 61131-2) by additional supply
Sensor supply US	max.200 mA externally or from AS Interface, (short circuit and overload protected)
Type	for 3-wire sensors or mechanical switches, p-switching (EN 61131-2)
Input current	max. 10 mA
Output	
Supply voltage	24 V DC (18...30.2 V DC) EN 61131-2 by additional supply, safely separated from input supply
Switching current per output	max. 0.5 A (short-circuit and overload protected)
Total current	max. 2 A
Switch off time in case of short circuit	approx. 20 ms
Diagnostic	
Communication status	via LED
Diagnostic via LED	per module
Monitoring - no voltage	yes
General data	
Protection	IP20
Connection	Spring clamp plug-in terminal: 0.2...2.5 mm ²
Mounting method	DIN-rail mountable (EN 60715)
Temperature range	0...+60 °C (storage temperature -20...+70 °C)
Dimension drawing	

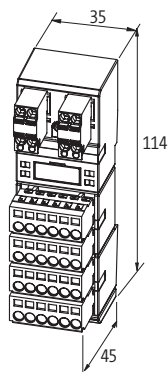

Notes

System Components	Article No.	Description
	56458	Gateway EtherCAT / AS-i, 2 Master 3.0, IP20
	56465	Gateway Profibus-DP / AS-i, 1 Master 3.0, IP20
	56466	Gateway Profinet-IO / AS-i, 1 Master 3.0, IP20
	56467	Gateway Ethernet-IP / AS-i, 1 Master 3.0, IP20
	56469	Gateway Ethernet-IP / AS-i-24, 1 Master 3.0, IP20, Power24
	56470	Gateway Profinet-IO / AS-i-24, 1 Master 3.0, IP20, Power24
	56471	Gateway Profibus-DP / AS-i-24, 1 Master 3.0, IP20, Power24
	56472	Gateway EtherCAT / AS-i-24, 1 Master 3.0, IP20, Power24
	56473	Gateway CC-Link / AS-i-24, 1 Master 3.0, IP20, Power24
	85381	MCS-A ASI power supply 1-phase, IN:95-265VAC OUT: 30.5V / 4ADC
	85382	MCS-A ASI power supply 1-phase, IN:95-265VAC OUT: 30.5V / 4ADC, signal contact



MA SI67

FLAT CABLES TAKE SYSTEMS INTO THE FIELD

- One module switches off two circuits
- Active and passive components
- Flat cable can be inserted multiple times

AS INTERFACE SYSTEM – MASI67

With MASI67, Murrelektronik provides an optimized installation system for mechanical engineering. The potted I/O modules are extremely resistant to mechanical influences such as vibration and shocks, and are sealed to meet industrial requirements. Having two outputs in one M12 port reduces valve installation by as much as 50 %.

The product range is supplemented with passive installation technology modules with practical interfaces for round cables, which are typically used in C-track applications.

They are designed according to the latest 3.0 AS Interface specification and have the globally recognized AS Interface certification, which guarantees that they are interoperable and a secure investment. With the special K3 module you can create safety shut downs according to EN 13849-1 up to PL d.



➤ MASI65

For I/O modules, accessories and more information about MASI65 see our **online-Shop**:

➤ onlineshop.murrelektronik.com

I/O-Modules



- With M8 connections**
- IP67 protection

Page 4.8.1



- With M12 connections**
- IP67 protection

Page 4.8.3

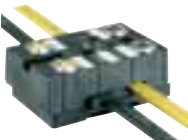

- With M12 connections and safe outputs**
- IP67 protection
 - Two release circuits
 - Safety

Page 4.8.4

Installation Technology



- Converter
- Accessories

Page 4.8.5

MASI67

Digital inputs

– M8 Round Plug Connectors

MASI67

DI4 - 0.2 A (AB) 4×M8



MASI67

DI8 - 0.24 A (AB) 8×M8

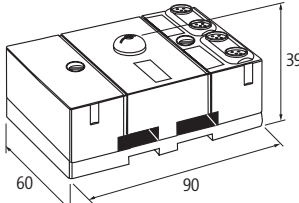
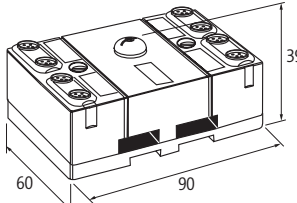

Approvals:   

Order Data	Art-No.	Art-No.
DI4 - 0.2 A (AB) 4×M8	56405	
DI8 - 0.24 A (AB) 8×M8		56406
Technical Data		
Bus voltage (AS-Interface)	26.5...31.6 V DC	
Total current (AS-Interface)	max. 250 mA	max. 290 mA
Addressing	via built-in address port or master	
Address range	1...62 (1...31 A or B)	2 × 1...62 (2 × 1...31 A or B)
Profile (IO/ID/ID2 code)	S-0.A.0	2 × S-0.A.0
Input		
Type	for 3-wire sensors or mechanical switches, p-switching (EN 61131-2)	
Sensor supply US	max. 200 mA from AS-Interface (short-circuit and overload protected)	max. 240 mA from AS-Interface (short-circuit and overload protected)
Diagnostic		
Communication status	via LED	
Diagnostic via LED	per module	
Monitoring - no voltage	yes	
General data		
Protection	IP67	
Mounting method	DIN-rail mountable (EN 60715) or screw fixing	
Temperature range	-20...+60 °C (storage temperature -20...+70 °C)	
Dimension drawing		
		
Notes		

MASI67

Digital inputs and outputs

– M8 Round Plug Connectors

Approvals:   

MASI67

DI4 - 0.2 A DO4 - 0.5 A 8×M8



Order Data	Art-No.
DI4 - 0.2 A DO4 - 0.5 A 8×M8	56408
Technical Data	
Bus voltage (AS-Interface)	26.5...31.6 V DC
Total current (AS-Interface)	max. 250 mA
Addressing	via built-in address port or master
Address range	1...31
Profile (IO/ID/ID2 code)	S-7.0.E
Input	
Type	for 3-wire sensors or mechanical switches, p-switching (EN 61131-2)
Sensor supply US	max. 200 mA from AS-Interface (short-circuit and overload protected)
Output	
Supply voltage	24 V DC external (18...30.2 V DC) EN 61131-2, connection via black AS-Interface profile cable
Switching current per output	max. 0.5 A (short-circuit and overload protected)
Total current	max. 2 A
Diagnostic	
Communication status	via LED
Diagnostic via LED	per module
Monitoring - no voltage	yes
General data	
Protection	IP67
Mounting method	DIN-rail mountable (EN 60715) or screw fixing
Temperature range	-20...+60 °C (storage temperature -20...+70 °C)
Dimension drawing	

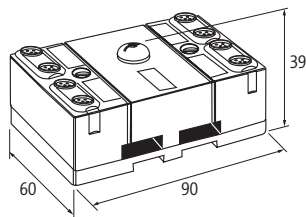

Notes

MASI67

Digital inputs and outputs

– M12 Round Plug Connectors

Approvals:

MASI67

DI4 - 0.2 A (AB) 4×M12



MASI67

DI8 - 0.24 A (AB) 4×M12

MASI67

DI4 - 1.6 A DO4 - 2 A 4×M12



Order Data	Art-No.	Art-No.	Art-No.
DI4 - 0.2 A (AB) 4×M12	56400		
DI8 - 0.24 A (AB) 4×M12		56401	
DI4 - 1.6 A DO4 - 2 A 4×M12			56404
Technical Data			
Bus voltage (AS-Interface)	26.5...31.6 V DC		
Total current	max. 250 mA	max. 290 mA	max. 50 mA
Addressing	via built-in address port or master		
Address range	1...62 (1...31 A or B)	2 × 1...62 (2 × 1...31 A or B)	1...31
Profile (IO/ID/ID2 code)	S-0.A.0	S-0.A.2	S-7.FE
Double assignment of M12 female	no	yes	
PIN 2 and PIN 4 of M12 female bridged	yes	no	–
Input			
Sensor supply US	max. 200 mA from AS-Interface (short-circuit and overload protected)	max. 240 mA from AS-Interface (short-circuit and overload protected)	max. 1.6 A external, (short-circuit and overload protected)
Type	for 3-wire sensors or mechanical switches, p-switching (EN 61131-2)		
Output			
Actuator supply UA	–		24 V DC external (18...30.2 V DC) EN 61131-2
Switching current per output	–		max. 2 A (short-circuit and overload protected)
Total current	–		max. 8 A
Diagnostic			
Communication status	via LED		
Diagnostic via LED	per module		
Diagnostic via BUS	yes	–	
Monitoring - no voltage	–	yes	
General data			
Protection	IP67		
Mounting method	DIN-rail mountable (EN 60715) or screw fixing		
Temperature range	-20...+60 °C (storage temperature -20...+70 °C)		
Connection	–		AS-Interface profile cable (black)
Dimension drawing			

Notes

MASI67

Digital inputs

- Passive
- output groups up to PLd (EN ISO 13849-1) can be switched off via safety relays
- M12 Round Plug Connectors

Approvals:  

MASI67

DI4 - 0.2 A DO4 - 1.6 A (AB) 4×M12 (K3)



MASI67

DI8 - 0.34 A DO8 - 1.6 A (AB) 8×M12 (K3)

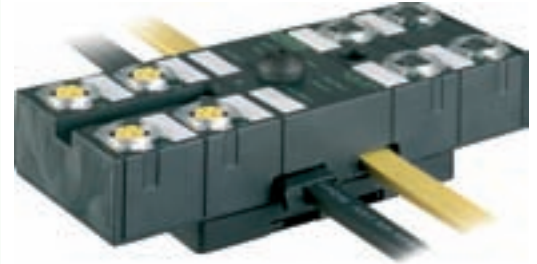

Order Data	Art-No.	Art-No.
DI4 - 0.2 A DO4 - 1.6 A (AB) 4×M12 (K3)	56414	
DI8 - 0.34 A DO8 - 1.6 A (AB) 8×M12 (K3)		56415

Technical Data		
Bus voltage (AS-Interface)	26.5...31.6 V DC	
Total current	max. 250 mA	max. 440 mA
Addressing	via built-in address port or master	
Address range	1...62 (1...31 A or B)	2 × 1...62 (2 × 1...31 A or B)
Profile (IO/ID/ID2 code)	S-7.A.7	2 × S-7.A.7
Double assignment of M12 female	yes	

Input		
Type	for 3-wire sensors or mechanical switches, p-switching (EN 61131-2)	
Sensor supply US	max. 200 mA from AS-Interface (short-circuit and overload protected)	max. 340 mA from AS-Interface, (short-circuit and overload protected)

Output		
Supply voltage	24 V DC external (18...30.2 V DC) EN 61131-2, connection via black AS-Interface profile cable	24 V DC external (18...30.2 V DC) EN 61131-2, connection via black AS-Interface profile cable, 2 safely separated supplies possible
Switching current per output	max. 1.6 A (short-circuit and overload protected)	
Total current	2 × 3.2 A	2 × 4 A

Diagnostic		
Communication status	via LED	
Diagnostic via LED	per module	
Monitoring - no voltage	yes	

General data		
Protection	IP67	
Mounting method	DIN-rail mountable (EN 60715) or screw fixing	
Temperature range	-20...+60 °C (storage temperature -20...+70 °C)	

Dimension drawing

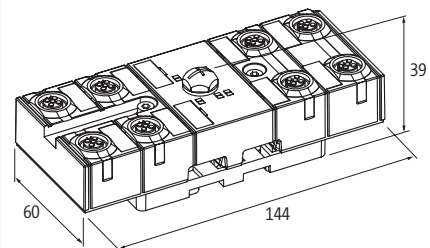
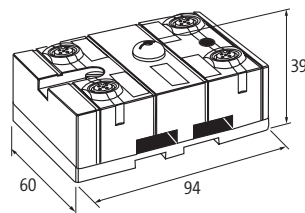

Notes

Connection accessories			Art-No.
	AS-Interface Distributor from profile to profile cable	AS-Interface	55749
Installation technology			Art-No.
	MASI67 converter 2 × profile cable to 7/8" (female)	AS-Interface	55035
	MASI67 converter 2 × profile cable to 7/8" (male)	AS-Interface	55036
	MASI67 converter 2 × profile cable to M12 (female)	AS-Interface	55037
	MASI67 converter 2 × profile cable to M12 (male)	AS-Interface	55038
	MASI67 distribution boxes 1 × on 3 × profile cable	AS-Interface	55034
	MASI67 connection 2 × on 2 × profile cable	AS-Interface	55033
	MASI67 passive distribution box 2 × profile cable to 4 × M12 (female)	AS-Interface	56412
	MASI67 passive distribution box 2 × profile cable to 4 × M12 (female) 2 separate circuits	AS-Interface	56416



MASI68

ROUND CABLES TAKE SYSTEMS INTO THE FIELD

- Small and compact with high signal density
- Sealed to meet industrial requirements
- Easy to install with integrated bus distributor

AS INTERFACE SYSTEM – MASI68

The I/O modules of the MASI68 series, with bus connections and M12 standard cables, are designed for applications in exposed areas that require sealed components. They offer a complete solution with IP68/69K protection.

Accessories and special round cables complete the MASI68 range offering the user a total installation concept for decentralized installations. Pluggable round cables make installation and service much easier.

With MASI68 K3 modules, you can shutdown safely according to EN 13849-1 up to PL d. They are designed according to the latest 3.0 AS Interface specifications and have AS Interface certification, which guarantees that they are compatible.



Digital inputs



With M8 connections

- IP68 protection

see onlineshop.murrelektronik.com/en



With M12 connections

- IP68/69K protection

Page 4.9.1

Digital inputs/outputs



With M8 connections

- IP68 protection

see onlineshop.murrelektronik.com/en



With M12 connections

- IP68/69K protection
- Models with safe outputs (safety)

see onlineshop.murrelektronik.com/en

Installation technology



Converters/Accessories

Accessories for round cables
see page 3.6.24

see onlineshop.murrelektronik.com/en

MASI68

Digital inputs

– M12 Round Plug Connectors

MASI68

Expansion module

MASI68

Expansion module
Y-wiring

MASI68

Expansion module



Approvals:  

Order Data	Art-No.	Art-No.	Art-No.	Art-No.
DI4 - 0.2 A (E) 4×M12 (AB)	56425			
DI8 - 0.2 A (E) 4×M12 (AB)		56426		
DI4 - 0.2 A (E) 4×M12 (AB) AUX-Y			56443	
DI8 - 0.2 A (E) 4×M12 (AB) AUX				56444
Connections				
Fieldbus	M12, A-coded			
I/O ports	M12, 4-pole		M12, 5-pole	M12, 4-pole
Technical Data				
Bus voltage (AS-Interface)	26.5...31.6 V DC			
Addressing	via master or M12 connection and programming device			
Address range	1...62 (1...31 A or B)	2 × 1...62 (2 × 1...31 A or B)	1...62 (1...31 A or B)	2 × 1...62 (2 × 1...31 A or B)
Profile (IO/ID/ID2 code)	S-0.A.2	2 × S-0.A.2	S-0.A.2	2 × S-0.A.2
Total current	max. 250 mA			
Address presetting	–	Slave 1: address 31 A; Slave 2: address 31 B	–	–
Input				
Type	for 3-wire sensors or mechanical switches, p-switching (EN 61131-2)			
Sensor supply US	max. 200 mA from AS-Interface (short-circuit and overload protected)		max. 200 mA from AUX Power, (short-circuit and overload protected)	
M12 configuration	–		Y-wiring	–
Diagnostic				
Communication status	via LED			
Diagnostic via LED	per module			
Monitoring - no voltage	yes			
General data				
Protection	IP68			
Mounting method	screw fixing			
Temperature range	-20...+60 °C (storage temperature -20...+70 °C)			
Dimension drawing				

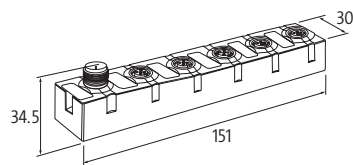

Notes	
-------	--



M8 DISTRIBUTION SYSTEMS EXACT8

- Saves space
- Versatile
- Application oriented

EXACT8 – THE NEW GENERATION OF MURRELEKTRONIK'S M8 DISTRIBUTION BOXES

- Small dimensions (30 mm width)
- PUR/PVC cable for flexible and fixed assembly
- High-quality, halogen-free PUR cable suitable for C-tracks, UL/CSA approved
- Standard or side mounting for limited space
- Quick and easy replacement of connection cables
- Without LED (with LED for NPN-signals on request)

For Sensors and Actuators – Molded Homerun Cables or Connection Caps

 <p>Exact8</p> <ul style="list-style-type: none">• 4-, 6-, 8-, 10-way• PUR or PUR/PVC homerun cable <p><i>Page 4.10.1</i></p>	 <p>Exact8 Basic Modules</p> <ul style="list-style-type: none">• 4-, 6-, 8-, 10-way <p><i>see onlineshop.murrelektronik.com/en</i></p>
 <p>Exact8 Connection Caps</p> <ul style="list-style-type: none">• Pre-wired• PUR or PUR/PVC homerun cable <p><i>see onlineshop.murrelektronik.com/en</i></p>	 <p>Exact8 Set</p> <ul style="list-style-type: none">• 4-, 6-, 8-, 10-way• Field-wireable <p><i>Page 4.10.3</i></p>

For Sensors – with M12 Connection

 <p>Exact8</p> <ul style="list-style-type: none">• 4-, 6-, 8-, 10-way• with 8- or 12-pole M12 connection <p><i>Page 4.10.4</i></p>
--

M8 DISTRIBUTION SYSTEMS

For sensors and actuators

– with molded homerun cable

– inline face or side mounting



Exact8

4-way



Exact8

6-way



Exact8

8-way



Exact8

10-way



1 Form	84 010	86 010	88 010	80 010															
Type	PNP, 3-pole	PNP, 3-pole	PNP, 3-pole	PNP, 3-pole															
Contact layout	<p>M8-Females 3-pole</p> <p>for 1 signal per port</p>																		
2 Cable Type	<p>Jacket Color – No./diameter of wires</p> <table border="1"> <thead> <tr> <th></th> <th>gray</th> <th>gray</th> <th>gray</th> <th>gray</th> </tr> </thead> <tbody> <tr> <td>PUR/PVC</td> <td>337 – 4 × 0.34 + 2 × 0.75 mm²</td> <td>350 – 6 × 0.34 + 2 × 0.75 mm²</td> <td>357 – 8 × 0.34 + 2 × 0.75 mm²</td> <td>385 – 10 × 0.34 + 2 × 0.75 mm²</td> </tr> <tr> <td>PUR (UL/CSA)</td> <td>334 – 4 × 0.34 + 2 × 0.75 mm²</td> <td>356 – 6 × 0.34 + 2 × 0.75 mm²</td> <td>359 – 8 × 0.34 + 2 × 0.75 mm²</td> <td>384 – 10 × 0.34 + 2 × 0.75 mm²</td> </tr> </tbody> </table>					gray	gray	gray	gray	PUR/PVC	337 – 4 × 0.34 + 2 × 0.75 mm ²	350 – 6 × 0.34 + 2 × 0.75 mm ²	357 – 8 × 0.34 + 2 × 0.75 mm ²	385 – 10 × 0.34 + 2 × 0.75 mm ²	PUR (UL/CSA)	334 – 4 × 0.34 + 2 × 0.75 mm ²	356 – 6 × 0.34 + 2 × 0.75 mm ²	359 – 8 × 0.34 + 2 × 0.75 mm ²	384 – 10 × 0.34 + 2 × 0.75 mm ²
	gray	gray	gray	gray															
PUR/PVC	337 – 4 × 0.34 + 2 × 0.75 mm ²	350 – 6 × 0.34 + 2 × 0.75 mm ²	357 – 8 × 0.34 + 2 × 0.75 mm ²	385 – 10 × 0.34 + 2 × 0.75 mm ²															
PUR (UL/CSA)	334 – 4 × 0.34 + 2 × 0.75 mm ²	356 – 6 × 0.34 + 2 × 0.75 mm ²	359 – 8 × 0.34 + 2 × 0.75 mm ²	384 – 10 × 0.34 + 2 × 0.75 mm ²															
3 Cable Length	<table border="1"> <tbody> <tr> <td>3.0 m</td> <td>0300</td> </tr> <tr> <td>5.0 m</td> <td>0500</td> </tr> <tr> <td>10.0 m</td> <td>1000</td> </tr> <tr> <td>15.0 m</td> <td>1500</td> </tr> </tbody> </table>				3.0 m	0300	5.0 m	0500	10.0 m	1000	15.0 m	1500							
3.0 m	0300																		
5.0 m	0500																		
10.0 m	1000																		
15.0 m	1500																		
Technical Data	<table border="1"> <tbody> <tr> <td>Operating voltage</td> <td>24 V DC</td> </tr> <tr> <td>Total current</td> <td>max. 10 A</td> </tr> <tr> <td>Protection</td> <td>IP65/IP67</td> </tr> <tr> <td>Temperature range</td> <td>-20...+80 °C, depending on cable quality</td> </tr> </tbody> </table>				Operating voltage	24 V DC	Total current	max. 10 A	Protection	IP65/IP67	Temperature range	-20...+80 °C, depending on cable quality							
Operating voltage	24 V DC																		
Total current	max. 10 A																		
Protection	IP65/IP67																		
Temperature range	-20...+80 °C, depending on cable quality																		
Contact Layout	<table border="1"> <tbody> <tr> <td>Contact 1</td> <td>(+)</td> </tr> <tr> <td>Contact 3</td> <td>(-)</td> </tr> <tr> <td>Contact 4</td> <td>(NO)/(S1)</td> </tr> <tr> <td>LED display</td> <td>LED (green): Power / LED (yellow): (S1)</td> </tr> </tbody> </table>				Contact 1	(+)	Contact 3	(-)	Contact 4	(NO)/(S1)	LED display	LED (green): Power / LED (yellow): (S1)							
Contact 1	(+)																		
Contact 3	(-)																		
Contact 4	(NO)/(S1)																		
LED display	LED (green): Power / LED (yellow): (S1)																		
Article No.	<table border="1"> <tbody> <tr> <td>The composition of your article number is explained on page 3.1.i</td> <td>8 0 0 0</td> <td>-</td> <td>-</td> <td>-</td> </tr> </tbody> </table>				The composition of your article number is explained on page 3.1.i	8 0 0 0	-	-	-										
The composition of your article number is explained on page 3.1.i	8 0 0 0	-	-	-															
	1 Form	2 Cable Type	3 Cable Length																
Notes																			

M8 DISTRIBUTION SYSTEMS

For sensors and actuators

- with molded homerun cable
- inline face or side mounting



1 Form	84110	86110	88110	80110															
Type	PNP, 4-pole	PNP, 4-pole	PNP, 4-pole	PNP, 4-pole															
Contact layout	M8-Females 4-pole for 2 signals per port																		
2 Cable Type	Jacket Color – No./diameter of wires <table border="1"> <thead> <tr> <th></th> <th>gray</th> <th>gray</th> <th>gray</th> <th>gray</th> </tr> </thead> <tbody> <tr> <td>PUR/PVC</td> <td>358 – 8 × 0.34 + 2 × 0.75 mm²</td> <td>386 – 12 × 0.34 + 2 × 0.75 mm²</td> <td>395 – 16 × 0.34 + 2 × 0.75 mm²</td> <td>412 – 20 × 0.34 + 2 × 0.75 mm²</td> </tr> <tr> <td>PUR (UL/CSA)</td> <td>360 – 8 × 0.34 + 2 × 0.75 mm²</td> <td>389 – 12 × 0.34 + 2 × 0.75 mm²</td> <td>396 – 16 × 0.34 + 2 × 0.75 mm²</td> <td>411 – 20 × 0.34 + 2 × 0.75 mm²</td> </tr> </tbody> </table>					gray	gray	gray	gray	PUR/PVC	358 – 8 × 0.34 + 2 × 0.75 mm ²	386 – 12 × 0.34 + 2 × 0.75 mm ²	395 – 16 × 0.34 + 2 × 0.75 mm ²	412 – 20 × 0.34 + 2 × 0.75 mm ²	PUR (UL/CSA)	360 – 8 × 0.34 + 2 × 0.75 mm ²	389 – 12 × 0.34 + 2 × 0.75 mm ²	396 – 16 × 0.34 + 2 × 0.75 mm ²	411 – 20 × 0.34 + 2 × 0.75 mm ²
	gray	gray	gray	gray															
PUR/PVC	358 – 8 × 0.34 + 2 × 0.75 mm ²	386 – 12 × 0.34 + 2 × 0.75 mm ²	395 – 16 × 0.34 + 2 × 0.75 mm ²	412 – 20 × 0.34 + 2 × 0.75 mm ²															
PUR (UL/CSA)	360 – 8 × 0.34 + 2 × 0.75 mm ²	389 – 12 × 0.34 + 2 × 0.75 mm ²	396 – 16 × 0.34 + 2 × 0.75 mm ²	411 – 20 × 0.34 + 2 × 0.75 mm ²															
3 Cable Length	<table border="1"> <tbody> <tr> <td>3.0 m</td> <td>0300</td> </tr> <tr> <td>5.0 m</td> <td>0500</td> </tr> <tr> <td>10.0 m</td> <td>1000</td> </tr> <tr> <td>15.0 m</td> <td>1500</td> </tr> </tbody> </table>				3.0 m	0300	5.0 m	0500	10.0 m	1000	15.0 m	1500							
3.0 m	0300																		
5.0 m	0500																		
10.0 m	1000																		
15.0 m	1500																		
Technical Data	<table border="1"> <tbody> <tr> <td>Operating voltage</td> <td>24 V DC</td> </tr> <tr> <td>Total current</td> <td>max. 10 A</td> </tr> <tr> <td>Protection</td> <td>IP65/IP67</td> </tr> <tr> <td>Temperature range</td> <td>-20...+80 °C, depending on cable quality</td> </tr> </tbody> </table>				Operating voltage	24 V DC	Total current	max. 10 A	Protection	IP65/IP67	Temperature range	-20...+80 °C, depending on cable quality							
Operating voltage	24 V DC																		
Total current	max. 10 A																		
Protection	IP65/IP67																		
Temperature range	-20...+80 °C, depending on cable quality																		
Contact Layout	<table border="1"> <tbody> <tr> <td>Contact 1</td> <td>(+)</td> </tr> <tr> <td>Contact 2</td> <td>(NC)/(S2)</td> </tr> <tr> <td>Contact 3</td> <td>(-)</td> </tr> <tr> <td>Contact 4</td> <td>(NO)/(S1)</td> </tr> <tr> <td>LED display</td> <td>LED (green): Power / LED (yellow): (S1) / LED (white): Signal (S2)</td> </tr> </tbody> </table>				Contact 1	(+)	Contact 2	(NC)/(S2)	Contact 3	(-)	Contact 4	(NO)/(S1)	LED display	LED (green): Power / LED (yellow): (S1) / LED (white): Signal (S2)					
Contact 1	(+)																		
Contact 2	(NC)/(S2)																		
Contact 3	(-)																		
Contact 4	(NO)/(S1)																		
LED display	LED (green): Power / LED (yellow): (S1) / LED (white): Signal (S2)																		
Article No.	<table border="1"> <tbody> <tr> <td>The composition of your article number is explained on page 3.1.i</td> <td>8 0 0 0</td> <td>-</td> <td>-</td> <td>-</td> </tr> </tbody> </table>				The composition of your article number is explained on page 3.1.i	8 0 0 0	-	-	-										
The composition of your article number is explained on page 3.1.i	8 0 0 0	-	-	-															
	1 Form	2 Cable Type	3 Cable Length																
Notes																			

M8 Distribution Systems

M8 DISTRIBUTION SYSTEMS

For sensors and actuators

– Sets (basic module and cap)

– inline face or side mounting



Exact8

4-way



Exact8

6-way



Exact8

8-way



Exact8

10-way



1 Form	84040	86040	88040	80040								
Type	3-pole	3-pole	3-pole	3-pole								
Contact layout	<p>M8-Females 3-pole</p> <p>for 1 signal per port</p>											
2 Cable Type	<p>Jacket Color – No./diameter of wires</p> <table border="1"> <thead> <tr> <th>gray</th> <th>gray</th> <th>gray</th> <th>gray</th> </tr> </thead> <tbody> <tr> <td>334 – 4 × 0.34 + 2 × 0.75 mm²</td> <td>356 – 6 × 0.34 + 2 × 0.75 mm²</td> <td>359 – 8 × 0.34 + 2 × 0.75 mm²</td> <td>384 – 10 × 0.34 + 2 × 0.75 mm²</td> </tr> </tbody> </table>				gray	gray	gray	gray	334 – 4 × 0.34 + 2 × 0.75 mm ²	356 – 6 × 0.34 + 2 × 0.75 mm ²	359 – 8 × 0.34 + 2 × 0.75 mm ²	384 – 10 × 0.34 + 2 × 0.75 mm ²
gray	gray	gray	gray									
334 – 4 × 0.34 + 2 × 0.75 mm ²	356 – 6 × 0.34 + 2 × 0.75 mm ²	359 – 8 × 0.34 + 2 × 0.75 mm ²	384 – 10 × 0.34 + 2 × 0.75 mm ²									
3 Cable Length	<table border="1"> <tbody> <tr> <td>3.0 m</td> <td>0300</td> </tr> <tr> <td>5.0 m</td> <td>0500</td> </tr> <tr> <td>10.0 m</td> <td>1000</td> </tr> <tr> <td>15.0 m</td> <td>1500</td> </tr> </tbody> </table>				3.0 m	0300	5.0 m	0500	10.0 m	1000	15.0 m	1500
3.0 m	0300											
5.0 m	0500											
10.0 m	1000											
15.0 m	1500											
Technical Data	<table border="1"> <tbody> <tr> <td>Operating voltage</td> <td>24 V DC</td> </tr> <tr> <td>Total current</td> <td>max. 8 A</td> </tr> <tr> <td>Protection</td> <td>IP67 inserted and tightened (EN 60529)</td> </tr> <tr> <td>Temperature range</td> <td>-20...+80 °C, depending on cable quality</td> </tr> </tbody> </table>				Operating voltage	24 V DC	Total current	max. 8 A	Protection	IP67 inserted and tightened (EN 60529)	Temperature range	-20...+80 °C, depending on cable quality
Operating voltage	24 V DC											
Total current	max. 8 A											
Protection	IP67 inserted and tightened (EN 60529)											
Temperature range	-20...+80 °C, depending on cable quality											
Contact Layout	<table border="1"> <tbody> <tr> <td>Contact 1</td> <td>(+)</td> </tr> <tr> <td>Contact 3</td> <td>(-)</td> </tr> <tr> <td>Contact 4</td> <td>(NO)/(S1)</td> </tr> <tr> <td>LED display</td> <td>LED (green): Power / LED (yellow): (S1)</td> </tr> </tbody> </table>				Contact 1	(+)	Contact 3	(-)	Contact 4	(NO)/(S1)	LED display	LED (green): Power / LED (yellow): (S1)
Contact 1	(+)											
Contact 3	(-)											
Contact 4	(NO)/(S1)											
LED display	LED (green): Power / LED (yellow): (S1)											
Article No.	<p>The composition of your article number is explained on page 3.1.i</p> <p>8 0 0 0 – _____ – _____</p>											
	1 Form	2 Cable Type	3 Cable Length									
Notes												

M8 DISTRIBUTION SYSTEMS

- For sensors
- M12 plug connection
 - 12-pole
 - inline face or side mounting



1 Form	84060	86060	88060	80060
Type	3-pole	3-pole	3-pole	3-pole
Contact layout	<p>for 1 signal per port</p>			
Technical Data				
Operating voltage	24 V DC			
Operating current per contact	max. 1.5 A			
Protection	IP67 inserted and tightened (EN 60529)			
Housing	Plastic, flame retardant			
Temperature range	-20...+70 °C, depending on cable quality			
Contact Layout				
Contact 1	(+)			
Contact 3	(-)			
Contact 4	(NO)/(S1)			
LED display	LED (green): Power / LED (yellow): (S1)			
Article No.				
The composition of your article number is explained on page 3.1.i	<u>8</u> <u>0</u> <u>0</u> <u>0</u>	-	-	<u>0</u> <u>0</u> <u>0</u> <u>0</u>
	1 Form			
Notes				

M8 Distribution Systems



M12 DISTRIBUTION SYSTEMS PLASTIC

- Fully potted, sealed
- Highly resistant
- Application oriented

PLUGGABLE CONNECTIONS FROM THE PROCESS TO THE CONTROL

- Quick installation with pre-wired and tested cables
- Easy to separate during transportation and simple when redesigning your system, rapid replacement of damaged cables
- Double assignment of M12 ports saves space
- Safety models for inputs and outputs according to EN ISO 13849-2
- Universal configuration – contacts designed 1:1

Pluggable or pre-wired homerun cable

 <p>Exact12</p> <ul style="list-style-type: none"> • 4-, 8-way • With LED for PNP or NPN signals • Without LED for voltages up to 125 V AC/DC • Analog signals <p style="text-align: right;"><i>Page 4.11.1</i></p>	 <p>Exact12</p> <ul style="list-style-type: none"> • 4-, 8-way • with 8- or 12-pole M12 connection <p style="text-align: right;"><i>Page 4.11.28</i></p>
--	--

With pluggable homerun cable

 <p>Exact12 Basic Module</p> <ul style="list-style-type: none"> • 4-, 8-way • With LED for PNP or NPN signals • Without LED for voltages up to 125 V AC/DC • Analog signals <p style="text-align: right;"><i>see onlineshop.murrelektronik.com/en</i></p>	 <p>Exact12/MVP12 connection caps</p> <ul style="list-style-type: none"> • Field-wireable with screw or spring clamp terminals • With pre-wired homerun cable and screw-plug terminals <p style="text-align: right;"><i>see onlineshop.murrelektronik.com/en</i></p>
 <p>Exact12 set</p> <ul style="list-style-type: none"> • 4-, 8-way • With pluggable cap and screw plug terminals or spring clamp terminals <p style="text-align: right;"><i>Page 4.11.4</i></p>	 <p>Exact12 with connection on the back</p> <ul style="list-style-type: none"> • 8-way • with pluggable connection on the back • Potential separation optional <p style="text-align: right;"><i>see onlineshop.murrelektronik.com/en</i></p>
 <p>Exact12/MVP12 universal</p> <ul style="list-style-type: none"> • 4-, 6-, 8-way • With pluggable 12- or 19-pole M23 connection • With pluggable connection cap • M12 pin 1, 2, 3, and 4 freely configurable <p style="text-align: right;"><i>Page 4.11.7</i></p>	 <p>MSDS – safety distribution system</p> <ul style="list-style-type: none"> • 8-way • With pluggable cap and screw terminals • With and without electrical feed back <p style="text-align: right;"><i>see onlineshop.murrelektronik.com/en</i></p>

M12 DISTRIBUTION SYSTEMS (PLASTIC)

For sensors and actuators

– with molded homerun cable

Exact12

4-way
for PNP signals 24 V DC



Exact12

8-way
for PNP signals 24 V DC

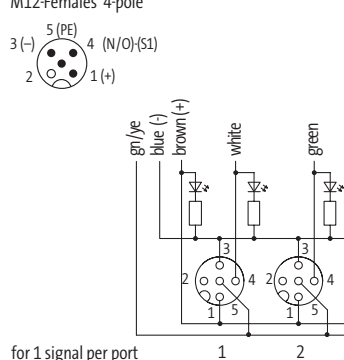
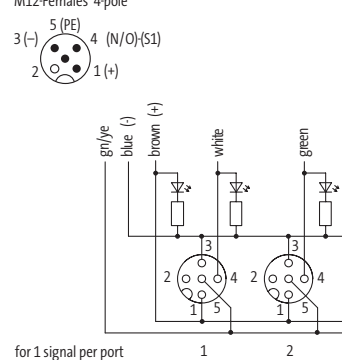

Approvals:  

1 Form		84410	88410
Type	PNP, 4-pole		PNP, 4-pole
Contact layout	M12-Females 4-pole  <p>for 1 signal per port</p>		M12-Females 4-pole  <p>for 1 signal per port</p>
2 Cable Type		Jacket Color – No./diameter of wires	
PUR/PVC		gray 333 – 4 × 0.34 + 3 × 0.75 mm ²	gray 362 – 8 × 0.34 + 3 × 0.75 mm ²
PUR (UL/CSA)			447 – 8 × 0.5 + 3 × 1.0 mm ²
3 Cable Length			
3.0 m		0300	
5.0 m		0500	
10.0 m		1000	
15.0 m		1500	
Technical Data			
Operating voltage		24 V DC	
Total current		max. 10 A	
Protection		IP65/IP67	
Temperature range		-20...+70 °C, depending on cable quality	
Contact Layout			
Contact 1		(+)	
Contact 3		(-)	
Contact 4		(NO)/(S1)	
Contact 5		(Earth)	
LED display		LED (green): Power / LED (yellow): (S1)	
Article No.			
The composition of your article number is explained on page 3.1.i		<div style="display: flex; justify-content: space-around; align-items: center;"> 8 0 0 0 - - </div>	
		1 Form	2 Cable Type
		3 Cable Length	
Notes		Further cable lengths on request.	

M12 DISTRIBUTION SYSTEMS (PLASTIC)

For sensors and actuators

– with molded homerun cable



Exact12

4-way
without LED



Exact12

8-way
without LED



1 Form

84412

without LED, 4-pole

M12-Females 4-pole

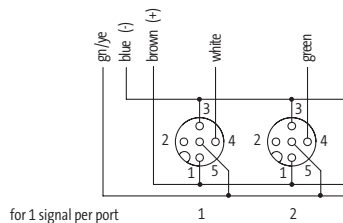
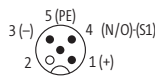

for 1 signal per port

88412

without LED, 4-pole

M12-Females 4-pole

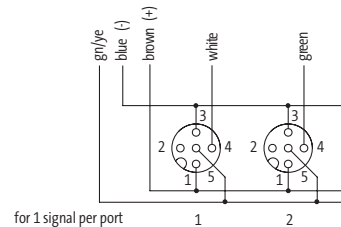
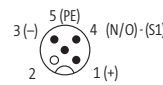

for 1 signal per port

2 Cable Type

Jacket Color – No./diameter of wires

gray

333 – 4 × 0.34 + 3 × 0.75 mm²

gray

362 – 8 × 0.34 + 3 × 0.75 mm²

447 – 8 × 0.5 + 3 × 1.0 mm²

3 Cable Length

5.0 m

0500

10.0 m

1000

Technical Data

Operating voltage

125 V AC/DC

Total current

max. 10 A

Protection

IP65/IP67

Temperature range

-20...+70 °C, depending on cable quality

Contact Layout

Contact 1

(+)

Contact 3

(-)

Contact 4

(NO)/(S1)

Contact 5

(Earth)

Article No.

The composition of your article number is explained on page 3.1.i

8 0 0 0 - - - - -

1 Form

2 Cable Type

3 Cable Length

Notes

Further cable lengths on request.

M12 DISTRIBUTION SYSTEMS (PLASTIC)

For sensors and actuators

– with molded homerun cable

Exact12

4-way
for PNP signals 24 V DC



Exact12

8-way
for PNP signals 24 V DC

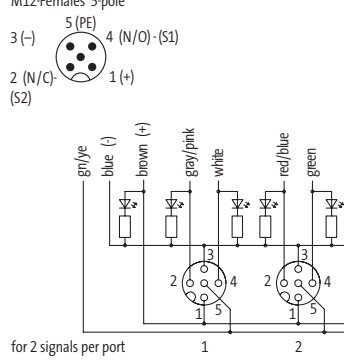
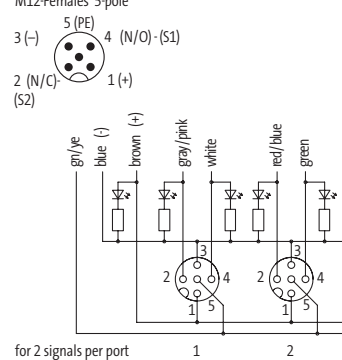

Approvals:  

1 Form		84510	88510
Type	PNP, 5-pole		PNP, 5-pole
Contact layout	M12-Females 5-pole 3 (-) 4 (N/O) - (S1) 2 (N/C) - (S2) 1 (+)  for 2 signals per port		M12-Females 5-pole 3 (-) 4 (N/O) - (S1) 2 (N/C) - (S2) 1 (+)  for 2 signals per port
2 Cable Type		Jacket Color – No./diameter of wires	
		gray	gray
PUR/PVC	363 – 8 × 0.34 + 3 × 0.75 mm ²		398 – 16 × 0.34 + 3 × 0.75 mm ²
PUR (UL/CSA)	448 – 8 × 0.5 + 3 × 1.0 mm ²		452 – 16 × 0.5 + 3 × 1.0 mm ²
3 Cable Length			
3.0 m		0300	
5.0 m		0500	
10.0 m		1000	
15.0 m		1500	
Technical Data			
Operating voltage	24 V DC		
Total current	max. 10 A		
Protection	IP65/IP67		
Temperature range	-20...+70 °C, depending on cable quality		
Contact Layout			
Contact 1	(+) (S2)		
Contact 2	(NC)/(S2)		
Contact 3	(-)		
Contact 4	(NO)/(S1)		
Contact 5	(Earth)		
LED display	LED (green): Power / LED (yellow): (S1) / LED (white): Signal (S2)		
Article No.			
The composition of your article number is explained on page 3.1.i		<div style="display: flex; justify-content: space-around; align-items: center;"> 8 0 0 0 - - </div>	
		1 Form	2 Cable Type
		3 Cable Length	
Notes		Further cable lengths on request.	

M12 DISTRIBUTION SYSTEMS (PLASTIC)

For sensors and actuators

– Sets (basic module and cap)

– Field-wireable



Exact12

4-way



1 Form	84440	84450	84451
Type	PNP, 4-pole Spring clamp plug-in terminals	PNP, 4-pole Screw plug-in terminals	NPN, 4-pole Screw plug-in terminals
Contact layout	M12-Females 4-pole for 1 signal per port		M12-Females 4-pole for 1 signal per port
Technical Data			
Operating voltage	24 V DC		
Operating current per contact	max. 4 A		
Total current	max. 8 A		
Connection	Spring clamp plug-in terminals: max. 1.5 mm ² (AWG 16)		Screw plug-in terminals: max. 1.5 mm ² (AWG 16)
Protection	IP65/IP67		
Housing	Plastic, flame retardant		
Temperature range	-20...+70 °C		
Contact Layout			
Contact 1	(+)		
Contact 3	(-)		
Contact 4	(NO)/(S1)		
Contact 5	(Earth)		
LED display	LED (green): Power / LED (yellow): (S1)		
Article No.			
The composition of your article number is explained on page 3.1.i	<div style="display: flex; justify-content: space-around; align-items: center;"> <u>8 0 0 0</u> - _____ - <u>0 0 0</u> <u>0 0 0 0</u> </div>		
	1 Form		
Notes			

M12 Distribution Systems (Plastic)

M12 DISTRIBUTION SYSTEMS (PLASTIC)

For sensors and actuators

– Sets (basic module and cap)

– Field-wireable



Exact12

4-way



1 Form	84540	84550
Type	PNP, 5-pole Spring clamp plug-in terminals	PNP, 5-pole Screw plug-in terminals
Contact layout	<p>M12-Females 5-pole</p> <p>3 (-) 5 (PE) 4 (N/O)/(S1) 1 (+)</p> <p>2 (N/C)/(S2)</p> <p>for 2 signals per port</p>	
Technical Data		
Operating voltage	24 V DC	
Operating current per contact	max. 4 A	
Total current	max. 8 A	
Connection	Spring clamp plug-in terminals: max. 1.5 mm ² (AWG 16)	Screw plug-in terminals: max. 1.5 mm ² (AWG 16)
Protection	IP65/IP67	
Housing	Plastic, flame retardant	
Temperature range	-20...+70 °C	
Contact Layout		
Contact 1	(+) (S2)	
Contact 2	(NC)/(S2)	
Contact 3	(-) (S1)	
Contact 4	(NO)/(S1)	
Contact 5	(Earth)	
LED display	LED (green): Power / LED (yellow): (S1) / LED (white): Signal (S2)	
Article No.		
The composition of your article number is explained on page 3.1.i	8 0 0 0 - 0 0 0 - 0 0 0 0	
	1 Form	
Notes		

M12 DISTRIBUTION SYSTEMS (PLASTIC)

For sensors and actuators

– M12 plug connection

Exact12

4-way



Exact12

8-way



Exact12

4-way



Approvals:

1 Form	84470	88460	84560																		
Type	5-, 4-pole M12 plug connection, 8-pole	5-, 4-pole M12 plug connection, 12-pole	5-pole M12 plug connection, 12-pole																		
Contact layout	<p>M12-Females</p> <p>5-pole 4-pole</p> <p>2 signals 1 signal</p> <p>M12-Plug</p> <p>8-pole</p> <p>M12-Plug 8-pole (-) (+) 7 5 1, 2, 6, 8 3+4</p> <p>1+2 3+4</p>	<p>M12-Females</p> <p>5-pole 4-pole</p> <p>2 signals 1 signal</p> <p>M12-Plug</p> <p>12-pole</p> <p>M12-Plug 12-pole (-) (+) 2 1 3, 4, 11, 12 5...10</p> <p>1+2 3...8</p>	<p>M12-Females</p> <p>5-pole</p> <p>M12-Plug</p> <p>12-pole</p> <p>M12-Plug 12-pole (-) (+) 2 1 5 3 9 4</p> <p>for 2 signals per port 1 2</p>																		
Technical Data	<table border="1"> <tr> <td>Operating voltage</td> <td colspan="2">24 V DC</td> </tr> <tr> <td>Operating current per contact</td> <td>max. 2 A</td> <td>max. 1.5 A</td> </tr> <tr> <td>Total current</td> <td>max. 2 A</td> <td>max. 1.5 A</td> </tr> <tr> <td>Protection</td> <td colspan="2">IP65/IP67</td> </tr> <tr> <td>Housing</td> <td colspan="2">Plastic, flame retardant</td> </tr> <tr> <td>Temperature range</td> <td colspan="2">-20...+70 °C</td> </tr> </table>			Operating voltage	24 V DC		Operating current per contact	max. 2 A	max. 1.5 A	Total current	max. 2 A	max. 1.5 A	Protection	IP65/IP67		Housing	Plastic, flame retardant		Temperature range	-20...+70 °C	
Operating voltage	24 V DC																				
Operating current per contact	max. 2 A	max. 1.5 A																			
Total current	max. 2 A	max. 1.5 A																			
Protection	IP65/IP67																				
Housing	Plastic, flame retardant																				
Temperature range	-20...+70 °C																				
Contact Layout	<table border="1"> <tr> <td>Contact 1</td> <td>(+)</td> </tr> <tr> <td>Contact 2</td> <td>(NC)/(S2)</td> </tr> <tr> <td>Contact 3</td> <td>(-)</td> </tr> <tr> <td>Contact 4</td> <td>(NO)/(S1)</td> </tr> <tr> <td>Contact 5</td> <td>(Earth)</td> </tr> <tr> <td>LED display</td> <td>LED (green): Power / LED (yellow): (S1) / LED (white): Signal (S2)</td> </tr> </table>			Contact 1	(+)	Contact 2	(NC)/(S2)	Contact 3	(-)	Contact 4	(NO)/(S1)	Contact 5	(Earth)	LED display	LED (green): Power / LED (yellow): (S1) / LED (white): Signal (S2)						
Contact 1	(+)																				
Contact 2	(NC)/(S2)																				
Contact 3	(-)																				
Contact 4	(NO)/(S1)																				
Contact 5	(Earth)																				
LED display	LED (green): Power / LED (yellow): (S1) / LED (white): Signal (S2)																				
Article No.	<table border="1"> <tr> <td style="text-align: center;">8 0 0 0</td> <td style="text-align: center;">-</td> <td style="text-align: center;">-</td> <td style="text-align: center;">0 0 0</td> <td style="text-align: center;">0 0 0 0</td> </tr> </table>			8 0 0 0	-	-	0 0 0	0 0 0 0													
8 0 0 0	-	-	0 0 0	0 0 0 0																	
The composition of your article number is explained on page 3.1.i	1 Form																				
Notes																					

M12 DISTRIBUTION SYSTEMS (PLASTIC)

For safety wiring

- with molded homerun cable
- Homerun cable with spring clamp terminals
- (EN ISO 13849-2)

Approvals:  

Exact12 Safety

8-way
for PNP signals 24 V DC

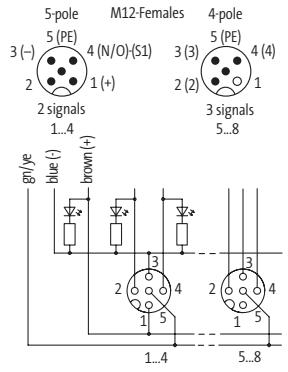

1 Form 98710

Type	PNP, 5-pole, 4/3-pole
Contact layout	

2 Cable Type Jacket Color - No./diameter of wires

	gray
PUR/PVC	407 - 20 x 0.34 + 3 x 0.75 mm ²

3 Cable Length

3.0 m	0300
5.0 m	0500
10.0 m	1000
15.0 m	1500

Technical Data

Operating voltage	24 V DC
Total current	max. 8 A
Protection	IP65/IP67
Temperature range	-20...+60 °C, depending on cable quality

Contact Layout

Contact 1	(+) port 1..4
Contact 2	(NC)/(S2) port 1..4; (S1) port 5..8
Contact 3	(-) port 1..4; (S2) port 5..8
Contact 4	(NO)/(S1) port 1..4; (S3) port 5..8
Contact 5	(Earth)
LED display	LED (green): Power / LED (yellow): (S1) / LED (white): Signal (S2) port 1..4

Article No.

The composition of your article number is explained on page 3.1.i	8 0 0 0 - 9 8 7 1 0 - _ _ _ _
	1 Form 2 Cable Type 3 Cable Length

Notes	
-------	--

INDEX

Art.-No.	page	Art.-No.	page	Art.-No.	page	Art.-No.	page	Art.-No.	page
5-digit Art.-No.								6-digit Art.-No.	
10415	1.4.1	55586	3.5.13	56616	4.1.4	85009	1.2.9	512498	1.5.3
10416	1.4.1	55587	3.5.13	56620	4.1.5	85010	1.2.9	564501	4.2.2
10510	1.4.2	55588	3.5.13	56621	4.1.6	85011	1.2.9		
10511	1.4.2	55685	4.7.3	56622	4.1.3	85016	1.2.9		
10512	1.4.2	55686	4.7.2	56623	4.1.4	85151	1.2.5		
10513	1.4.2	55687	4.7.2	56626	4.1.4	85152	1.2.5		
51403	1.5.3	55688	4.7.1	56631	4.1.6	85153	1.2.6		
52000	1.5.1	55700	4.7.1	56640	4.1.5	85154	1.2.6		
52001	1.5.1	55701	4.7.1	56651	4.1.14	85155	1.2.6		
52002	1.5.1	55749	4.8.5	56655	4.1.14	85301	1.2.3		
52003	1.5.2	55760	3.5.13	56656	4.1.14	85302	1.2.3		
52005	1.5.2	55762	3.5.13	56681	4.1.7	85303	1.2.3		
52015	1.5.1	55768	4.7.3	56691	4.1.7	85305	1.2.4		
52050	1.5.1	56001	4.2.1	56700	4.1.10	85307	1.2.4		
52501	1.6.1	56005	4.2.1	56701	4.1.10	85434	1.2.1		
52505	1.6.1	56006	4.2.1	56710	4.1.13	85437	1.2.1		
52519	1.6.2	56112	4.2.3	56711	4.1.13	85438	1.2.1		
52520	1.6.2	56117	4.2.3	56720	4.1.13	85439	1.2.1		
55033	4.8.5	56118	4.2.3	56721	4.1.13	85440	1.2.2		
55034	4.8.5	56168	4.2.3	56730	4.1.10	85441	1.2.2		
55035	4.8.5	56200	4.2.4	56731	4.1.10	85442	1.2.2		
55036	4.8.5	56220	4.2.6	56740	4.1.11	85640	1.2.8		
55037	4.8.5	56230	4.2.5	56741	4.1.11	85641	1.2.8		
55038	4.8.5	56240	4.2.5	56748	4.1.12	85642	1.2.8		
55071	4.5.6	56400	4.8.3	56749	4.1.12	85644	1.2.8		
55072	4.5.6	56401	4.8.3	56750	4.1.8	86070	1.1.3		
55073	4.5.6	56404	4.8.3	56760	4.1.9	86071	1.1.3		
55074	4.5.6	56405	4.8.1	56761	4.1.9	86090	1.1.3		
55075	4.5.5	56406	4.8.1	56771	4.1.8	86091	1.1.3		
55076	4.5.5	56408	4.8.2	56900	4.6.1	86110	1.1.3		
55077	4.5.5	56412	4.8.5	56901	4.6.1	86111	1.1.3		
55078	4.5.5	56414	4.8.4	56902	4.6.1	86130	1.1.3		
55081	4.5.4	56415	4.8.4	57101	4.3.1	86131	1.1.3		
55082	4.5.4	56416	4.8.5	57103	4.3.2	86145	1.1.2		
55083	4.5.4	56425	4.9.1	57104	4.3.1	86146	1.1.2		
55084	4.5.4	56426	4.9.1	57105	4.3.2	86147	1.1.2		
55085	4.5.3	56440	4.7.4	57106	4.3.2	86148	1.1.2		
55086	4.5.3	56443	4.9.1	57107	4.3.1	86150	1.1.2		
55087	4.5.3	56444	4.9.1	57108	4.3.2	86151	1.1.2		
55088	4.5.3	56450	4.2.2	57220	4.3.3	86152	1.1.2		
55091	4.5.2	56504	4.1.2	57240	4.3.3	86153	1.1.2		
55092	4.5.2	56505	4.1.2	57280	4.3.3	86154	1.1.2		
55093	4.5.2	56507	4.1.2	57320	4.3.4	86155	1.1.2		
55094	4.5.2	56521	4.1.1	57325	4.3.5	86157	1.1.2		
55287	4.4.1	56525	4.1.1	57327	4.3.5	86340	1.1.1		
55288	4.4.1	56526	4.1.1	57340	4.3.4	86341	1.1.1		
55289	4.4.1	56600	4.1.5	57345	4.3.5	86342	1.1.1		
55318	4.1.16	56601	4.1.6	57380	4.3.4	86343	1.1.1		
55345	4.5.1	56602	4.1.3	58170	1.7.1	86345	1.1.1		
55346	4.5.1	56603	4.1.4	58171	1.7.1	86346	1.1.1		
55347	4.5.1	56606	4.1.4	58172	1.7.1	86347	1.1.1		
55348	4.5.1	56610	4.1.5	85000	1.2.7	86348	1.1.1		
55583	3.5.13	56611	4.1.6	85001	1.2.7	86349	1.1.1		
55584	3.5.13	56612	4.1.3	85002	1.2.7	86351	1.1.1		
55585	3.5.13	56613	4.1.4	85004	1.2.7				

Art.-No.	page	Art.-No.	page	Art.-No.	page	Art.-No.	page	Art.-No.	page
7-digit Art.-No.				18-digit Art.-No.					
5665000	4.1.15	6686110	1.1.3	3000-33113-3020005	1.5.5	4000-75070-0000902	2.3.6	7000-08351-0000000	3.1.8
5665001	4.1.15	6686111	1.1.3	3000-33113-3020012	1.5.4	4000-75070-0000903	2.3.6	7000-08361-0000000	3.1.7
5665002	4.1.15	6686130	1.1.3	4000-68000-0010000	2.1.2	4000-75070-0000904	2.3.6	7000-08371-0000000	3.1.8
5665004	4.1.15	6686131	1.1.3	4000-68000-0030000	2.1.2	4000-75070-0000913	2.3.6	7000-08381-0000000	3.1.7
5665100	4.1.16	6686340	1.1.1	4000-68000-0060000	2.1.2	4000-75070-0000918	2.3.6	7000-08391-0000000	3.1.8
5665101	4.1.16	6686341	1.1.1	4000-68000-0090000	2.1.2	4000-75070-0000920	2.3.7	7000-08601-0000000	3.1.9
5665102	4.1.16	6686342	1.1.1	4000-68000-0100000	2.1.2	4000-75070-0000921	2.3.7	7000-08611-0000000	3.1.9
5665103	4.1.16	6686343	1.1.1	4000-68000-0820000	2.1.3	4000-75070-0000922	2.3.7	7000-08621-0000000	3.1.9
5665105	4.1.16	6686345	1.1.1	4000-68000-0990000	2.1.3	4000-75070-0000923	2.3.7	7000-08631-0000000	3.1.9
5665110	4.1.16	6686346	1.1.1	4000-68000-1040000	2.1.3	4000-75070-1011000	2.3.2	7000-12461-0000000	3.2.18
5665111	4.1.16	6686347	1.1.1	4000-68000-1040000	2.1.3	4000-75070-1012000	2.3.2	7000-12481-0000000	3.2.18
5665112	4.1.16	6686348	1.1.1	4000-68000-1420000	2.1.3	4000-75070-1012000	2.3.2	7000-12481-0000000	3.2.18
5665113	4.1.16	6686349	1.1.1	4000-68000-3210000	2.1.2	4000-75070-1013000	2.3.3	7000-12491-0000000	3.2.19
5665114	4.1.16	6686351	1.1.1	4000-68000-3250000	2.1.2	4000-75070-1014000	2.3.3	7000-12501-0000000	3.2.22
5665115	4.1.16			4000-68000-4010000	2.1.3	4000-75070-1015000	2.3.3	7000-12515-0000000	3.2.22
5665116	4.1.16			4000-68000-4230000	2.1.3	4000-75070-1021000	2.3.2	7000-12521-0000000	3.2.22
5665118	4.1.16			4000-68513-0000001	2.1.1	4000-75070-1022000	2.3.2	7000-12541-0000000	3.2.20
5665500	4.1.16			4000-68513-0000003	2.1.1	4000-75070-1025000	2.3.3	7000-12561-0000000	3.2.20
5665501	4.1.16			4000-68523-0000001	2.1.1	4000-75070-1100002	2.3.1	7000-12581-0000000	3.2.18
5665502	4.1.16			4000-68523-0000003	2.1.1	4000-75070-1100003	2.3.1	7000-12601-0000000	3.2.18
5665502	4.1.16			4000-69000-1040000	2.2.1	4000-75070-1100012	2.3.1	7000-12611-0000000	3.2.19
5665600	4.1.16			4000-69000-1050000	2.2.1	4000-75070-1300002	2.3.1	7000-12621-0000000	3.2.23
5665601	4.1.16			4000-69000-1060000	2.2.1	4000-75070-1300003	2.3.1	7000-12641-0000000	3.2.23
5665602	4.1.16			4000-69000-1080000	2.2.1	4000-75070-1300004	2.3.2	7000-12661-0000000	3.2.20
5665603	4.1.16			4000-69000-1100000	2.2.1	4000-75070-1300005	2.3.2	7000-12671-0000000	3.2.21
5665604	4.1.16			4000-69000-2000000	2.2.1	4000-75070-1300006	2.3.2	7000-12681-0000000	3.2.20
5665605	4.1.16			4000-69000-2040000	2.2.1	4000-75070-1300007	2.3.2	7000-12691-0000000	3.2.21
5665606	4.1.16			4000-69212-0000000	2.2.1	4000-75070-1300008	2.3.2	7000-12701-0000000	3.2.24
5665607	4.1.16			4000-69222-0000000	2.2.1	4000-75070-1300009	2.3.2	7000-12721-0000000	3.2.24
5665609	4.1.16			4000-73000-0010000	2.1.4	4000-75070-1400002	2.3.1	7000-12761-0000000	3.5.12
5665610	4.1.16			4000-73000-0150000	2.1.4	4000-75070-1400003	2.3.1	7000-12781-0000000	3.2.26
5665611	4.1.16			4000-73000-0160000	2.1.4	4000-75070-1400004	2.3.2	7000-12801-0000000	3.2.26
5665613	4.1.16			4000-73000-0170000	2.1.4	4000-75070-1400005	2.3.2	7000-12821-0000000	3.2.25
5665614	4.1.16			4000-73000-0180000	2.1.4	4000-75070-1400006	2.3.2	7000-12841-0000000	3.2.25
5665615	4.1.16			4000-75030-0000903	2.3.6	4000-75070-1400007	2.3.2	7000-12901-0000000	3.2.24
5665616	4.1.16			4000-75050-0000900	2.3.6	4000-75070-1400008	2.3.2	7000-12921-0000000	3.2.24
5665617	4.1.16			4000-75050-0000923	2.3.7	4000-75070-1400009	2.3.2	7000-12961-0000000	3.5.12
5665618	4.1.16			4000-75050-1011000	2.3.2	4000-75070-1500002	2.3.1	7000-12981-0000000	3.2.25
5667100	4.1.16			4000-75050-1012000	2.3.2	4000-75070-1500003	2.3.1	7000-13001-0000000	3.2.25
5667101	4.1.16			4000-75050-1013000	2.3.3	4000-75070-1500004	2.3.2	7000-13461-0000000	3.5.12
5668100	4.1.7			4000-75050-1014000	2.3.3	4000-75070-1500006	2.3.2	7000-14001-0000000	3.5.12
6652000	1.5.1			4000-75050-1015000	2.3.3	4000-75070-1500007	2.3.2	7000-14021-0000000	3.5.12
6652001	1.5.1			4000-75050-1100002	2.3.1	4000-75324-5310000	2.3.3	7000-14041-0000000	3.5.12
6652002	1.5.1			4000-75050-1100003	2.3.1	4000-75330-5310000	2.3.3	7000-15041-0000000	3.5.12,
6652003	1.5.2			4000-75057-1111000	2.3.4	4000-75501-5310000	2.3.3	4.1.16	
6652005	1.5.2			4000-75057-1112000	2.3.4	4000-75502-5310000	2.3.3	7000-29001-0000000	3.7.11
6652015	1.5.1			4000-75057-1113000	2.3.4	4000-75704-5310000	2.3.3	7000-29021-0000000	3.7.11
6652050	1.5.1			4000-75057-1114000	2.3.4	4000-75705-5310000	2.3.3	7000-29041-0000000	3.7.11
6652501	1.6.1			4000-75057-1115000	2.3.4	4000-75712-5310000	2.3.3	7000-29061-0000000	3.7.11
6652505	1.6.1			4000-75057-1311000	2.3.4	4000-75713-1358000	2.3.3	7000-29081-0000000	3.7.12
6652519	1.6.2			4000-75057-1312000	2.3.4	4000-75713-5310000	2.3.3	7000-29101-0000000	3.7.12
6652520	1.6.2			4000-75057-1313000	2.3.5	4000-75800-0000900	2.3.5	7000-29121-0000000	3.7.13
6686070	1.1.3			4000-75057-1314000	2.3.5	4000-75827-1315000	2.3.5	7000-29141-0000000	3.7.13
6686071	1.1.3			4000-75057-1315000	2.3.5	7000-08321-0000000	3.1.7	7000-29161-0000000	3.7.13
6686090	1.1.3			4000-75070-0000900	2.3.6	7000-08331-0000000	3.1.8	7000-29181-0000000	3.7.13
6686091	1.1.3			4000-75070-0000901	2.3.6	7000-08341-0000000	3.1.7	7000-29241-0000000	3.7.12

INDEX

Art.-No.	page	Art.-No.	page	Art.-No.	page	Art.-No.	page	Art.-No.	page
7000-29261-0000000	3.7.12	<i>Form without cable type and length</i>		7000-18061	3.7.2	8000-84410	4.11.1		
7000-29361-0000000	3.7.14	7000-08001	3.1.1	7000-18081	3.7.2	8000-84412	4.11.2		
7000-29381-0000000	3.7.14	7000-08011	3.1.1	7000-18121	3.7.3	8000-84510	4.11.3		
7000-29401-0000000	3.7.14	7000-08041	3.1.2	7000-18141	3.7.3	8000-86010	4.10.1		
7000-29421-0000000	3.7.14	7000-08061	3.1.2	7000-19001	3.2.3	8000-86040	4.10.3		
7000-41131-0000000	3.3.2	7000-08701	3.1.3	7000-19041	3.2.6	8000-86110	4.10.2		
7000-41135-0000000	3.3.2	7000-08711	3.1.3	7000-40001	3.2.13	8000-88010	4.10.1		
7000-41151-0000000	3.3.2	7000-08741	3.1.4	7000-40021	3.2.13	8000-88040	4.10.3		
7000-41191-0000000	3.3.2	7000-08761	3.1.4	7000-40041	3.2.13	8000-88110	4.10.2		
7000-41211-0000000	3.3.1	7000-10001	3.7.4	7000-40321	3.2.14	8000-88410	4.11.1		
7000-41231-0000000	3.3.1	7000-10021	3.7.4	7000-40341	3.2.14	8000-88412	4.11.2		
7000-46101-0000000	3.5.12	7000-10041	3.7.4	7000-40361	3.2.14	8000-88510	4.11.3		
7000-99051-0000000	3.5.12	7000-10061	3.7.5	7000-40481	3.2.16	8000-98710	4.11.9		
7000-99052-0000000	3.5.12	7000-10081	3.7.5	7000-40501	3.2.16				
7000-99441-0000000	3.5.13	7000-12001	3.2.1	7000-40521	3.2.16				
7000-C0201-7960000	3.5.13	7000-12021	3.2.1	7000-40531	3.5.6				
7000-C0201-8030000	3.5.13	7000-12041	3.2.1	7000-40551	3.5.6				
7000-C0201-8400000	3.5.12	7000-12181	3.2.4	7000-40561	3.2.17				
7060-42701-0000000	3.5.12	7000-12221	3.2.4	7000-40581	3.2.17				
8000-44742-0000000	4.11.8	7000-12241	3.2.4	7000-40701	3.2.15				
8000-44752-0000000	4.11.8	7000-12281	3.2.8	7000-40721	3.2.15				
8000-80060-0000000	4.10.4	7000-12321	3.2.7	7000-40881	3.7.9				
8000-84060-0000000	4.10.4	7000-12341	3.2.7	7000-40921	3.7.10				
8000-84440-0000000	4.11.4	7000-12361	3.2.7	7000-40931	3.7.10				
8000-84450-0000000	4.11.4	7000-12401	3.2.8	7000-41561	3.7.8				
8000-84451-0000000	4.11.4	7000-13061	3.2.9	7000-41581	3.7.8				
8000-84470-0000000	4.11.7	7000-13081	3.2.9	7000-41601	3.7.8				
8000-84540-0000000	4.11.5	7000-13101	3.2.9	7000-44001	3.5.3				
8000-84550-0000000	4.11.5	7000-13105	3.5.4	7000-44021	3.5.3				
8000-84560-0000000	4.11.7	7000-13125	3.5.4	7000-44511	3.5.8				
8000-86060-0000000	4.10.4	7000-13181	3.2.11	7000-44561	3.5.8				
8000-88060-0000000	4.10.4	7000-13201	3.2.11	7000-44711	3.5.9				
8000-88440-0000000	4.11.6	7000-13221	3.2.11	7000-44731	3.5.9				
8000-88450-0000000	4.11.6	7000-13225	3.5.5	7000-46041	3.5.11				
8000-88460-0000000	4.11.7	7000-13251	3.5.5	7000-46061	3.5.11				
9000-41034-0100400	1.3.3	7000-13541	3.4.1	7000-58001	3.7.7				
9000-41034-0100600	1.3.4	7000-13561	3.4.1	7000-58021	3.7.7				
9000-41034-0101000	1.3.6	7000-14051	3.5.1	7000-58041	3.7.7				
9000-41034-0401000	1.3.5	7000-14061	3.5.2	7000-70001	3.7.6				
9000-41034-0401005	1.3.6	7000-14071	3.5.2	7000-70021	3.7.6				
9000-41042-0100400	1.3.3	7000-14081	3.5.1	7000-74101	3.5.10				
9000-41042-0100600	1.3.4	7000-14541	3.5.7	7000-74121	3.5.10				
9000-41042-0401000	1.3.5	7000-14561	3.5.7	7000-74141	3.5.10				
9000-41064-0200000	1.3.8	7000-17001-292	3.2.2	7000-78021	3.6.14				
9000-41064-0400000	1.3.8	7000-17001-295	3.2.2	7000-78051	3.6.14				
9000-41064-0600000	1.3.8	7000-17041-292	3.2.5	7000-88001	3.1.5				
9000-41068-0200000	1.3.7	7000-17041-295	3.2.5	7000-88011	3.1.5				
9000-41068-0200600	1.3.9	7000-17081-291	3.2.10	7000-88241	3.1.6				
9000-41068-0400000	1.3.7	7000-17081-294	3.2.10	7000-88251	3.1.6				
9000-41068-0600000	1.3.7	7000-17121-291	3.2.12	8000-80010	4.10.1				
9000-41084-0100400	1.3.1	7000-17121-294	3.2.12	8000-80040	4.10.3				
9000-41084-0100600	1.3.1	7000-17181	3.4.1	8000-80110	4.10.2				
9000-41084-0401000	1.3.2	7000-18001	3.7.1	8000-84010	4.10.1				
		7000-18021	3.7.1	8000-84040	4.10.3				
		7000-18041	3.7.1	8000-84110	4.10.2				



stay connected

➤ www.murrelektronik.com

Part No. 9800502